

### DN 200 - 600

Standard construction

Valve operated by electric actuator AUMA type SA.. 3x400 V/50 Hz, Option: AUMA-MATIC rising stem

Material: on request

Coating: on request

Flange drilling: see table

Face-to-face dimension: see table

Pressure rating: 2,5 bar

Test pressure acc. to EN 12266-1 Leakage rate A

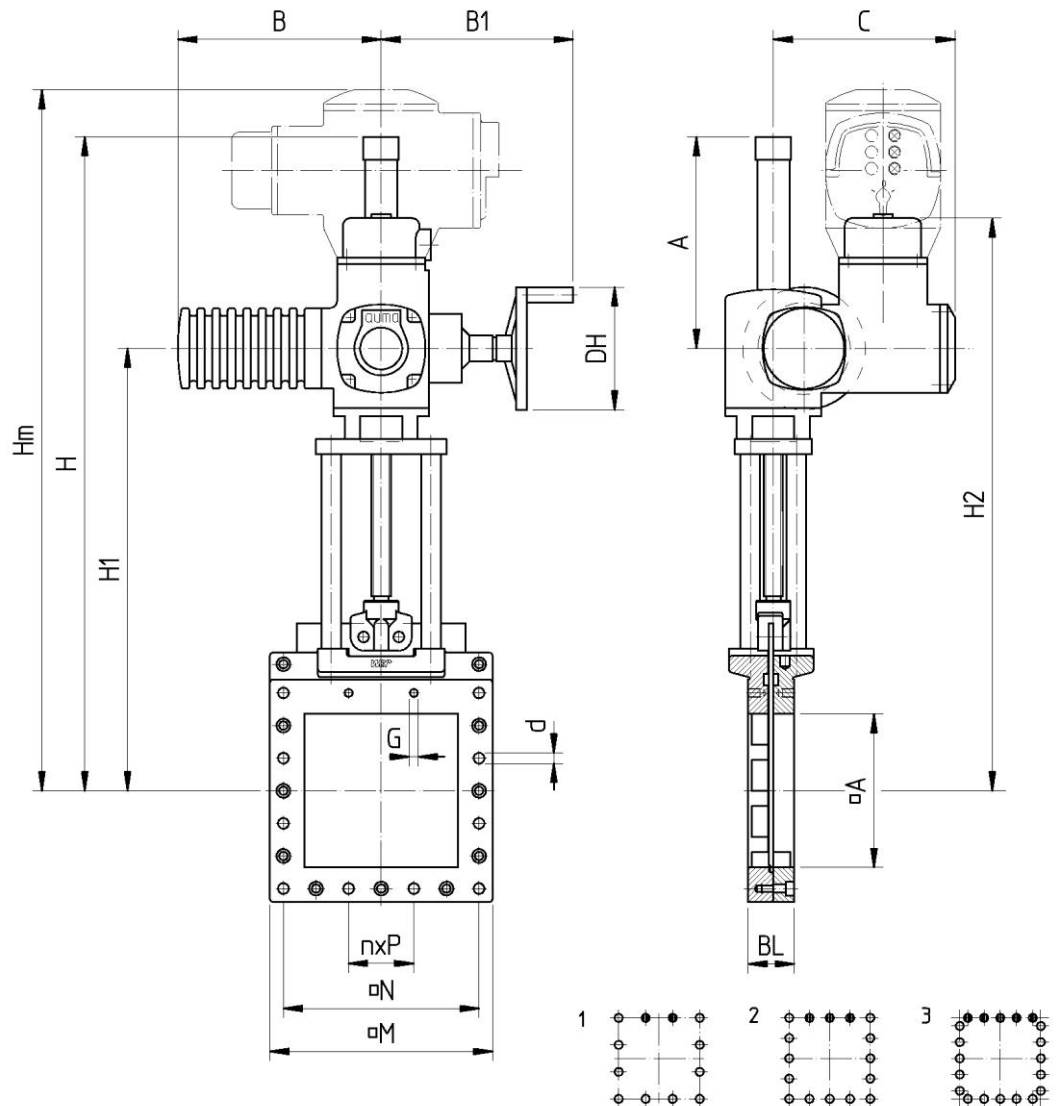

Alle Angaben unverbindlich Änderungen vorbehalten

□A	BL	H	H1	H2	Hm	DH	A	B	B1	C	Antrieb SA..	G	d	□M	□N	n x P	Flansch Bild
200	60	794	619	829	959	160	175	265	249	238	07.6	M12	14	290	255	3 x 85	1
250	70	1032	750	960	1090	200	282	283	254	248	10.2	M16	18	390	330	3 x 110	1
300	70	1117	835	1045	1175	200	282	283	254	248	10.2	M16	18	440	380	4 x 95	2
350	80	1322	940	1150	1280	200	382	283	254	248	10.2	M16	18	490	416	4 x 104	2
400	90	1397	1015	1225	1355	200	382	283	254	248	10.2	M20	22	540	480	4 x 96+	3
450	100	1531	1125	1351	1527	315	406	389	336	286	14.2	M20	22	595	550	5 x 110	1
500	110	1710	1204	1430	1606	315	506	389	336	286	14.2	M20	22	650	600	6 x 100	2
600	130	1962	1356	1582	1758	315	606	389	336	286	14.2	M20	22	760	700	7 x 100	1