



Forged Gate Valves
Fig. C800 Class 800
Size 1/2" – 2" (DN 15 – 50)



FIG. C800
GATE VALVE

API 602, MSS SP 118 & ASME B16.34

Connections according to:

ANSI B 1.20.1 (NPT)

ANSI B 16.11 (SW)





Forged Gate Valves

Fig. C800 Class 800

Parts and Materials

Parts and materials

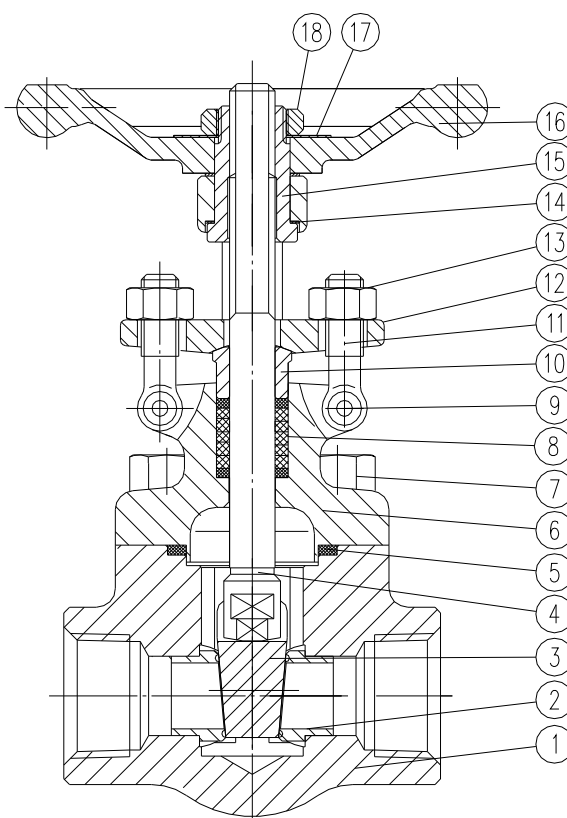

Item	Description	Material	
		Carbon Steel	Stainless Steel
1	Body	A 105	A 182 F316L
2	Seat	A 182 F6A + STL	A 182 F316L + STL
3	Gate	A 182 F6A + STL	A 182 F316L
4	Stem	AISI 410	A 182 F316L
5	Gasket	AISI 304 + Graphite	AISI 316 + Graphite
6	Bonnet	A 105	A 182 F316L
7	Bolt	A 193 B7	A 193 B8M
8	Packing	Flexible Graphite + Carbon Fibre	
9	Pin	AISI 420	AISI 304
10	Packing Gland	AISI 420	AISI 316L
11	Eye Bolt	A 193 B8	A 193 B8M
12	Gland Flange	A 105	A 182 F316L
13	Hex Nut	A 194 8	A 194 8M
14	Washer	AISI 410	
15	Yoke Nut	AISI 410	
16	Hand wheel	A 197	
17	Nameplate	Aluminium	
18	Hex Nut	1035 Zinc Plated	

RAM Forged Gate Valves

Fig. C800 Class 800

Dimensions

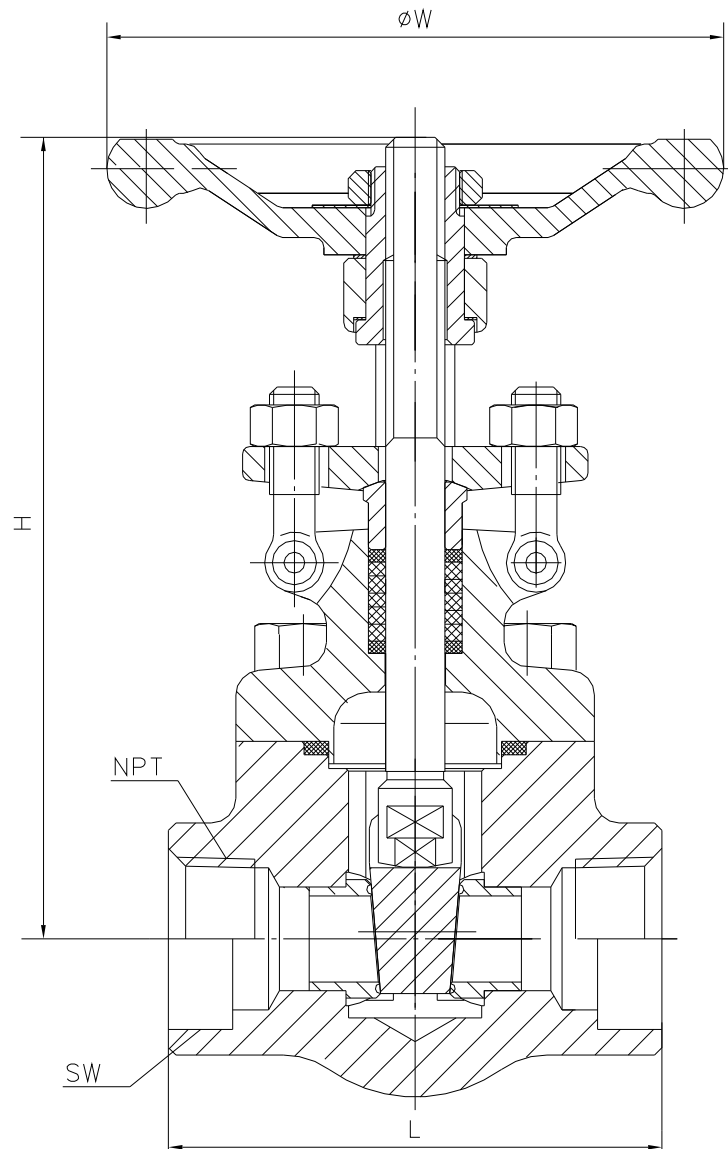

Dimensions

SIZE	L	NPT	ϕW	H	Weight
1/2" (DN 15)	79	1/2"	100	151	2,2
3/4" (DN 20)	92	3/4"	100	158	2,4
1" (DN 25)	110	1"	125	185	4,2
1 1/4" (DN 32)	120	1 1/4"	160	239	6
1 1/2" (DN 40)	120	1 1/2"	160	243	7
2" (DN 50)	140	2"	180	279	11

(*) Dimensions in mm and weight in kg.

Note:

Dimensions not subject to International Standards can vary in $\pm 10\%$. Ram Universal reserves the right to change those dimensions without notice, due to they do not affect integrity and performance of the valves.



Forged Gate Valves Fig. C800 Class 800

General Characteristics, Torque, KV, P&T Rating

GENERAL CHARACTERISTICS	Forged Gate Valve		
DESIGN STANDARDS			
Valves design	API 602	ASME B 16.34	
Connections	ANSI B 1.20.1	ANSI B 16.11	
Face to face dimensions	Manufacturer's standard		
TESTS AND CERTIFICATES	API 598		
Quality Assurance	ISO 9001		
Pressure testing	EN 12266-1		
Marking	EN 19		

Kv Values in m3/h

VALVE SIZE	Kv	VALVE SIZE	Kv
1/2" (DN 15)	5,6	1 1/4" (DN 32)	39
3/4" (DN 20)	9,6	1 1/2" (DN 40)	58
1" (DN 25)	21,6	2" (DN 50)	98

Pressure-Temperature

ASTM A105

MATERIAL

P Bar

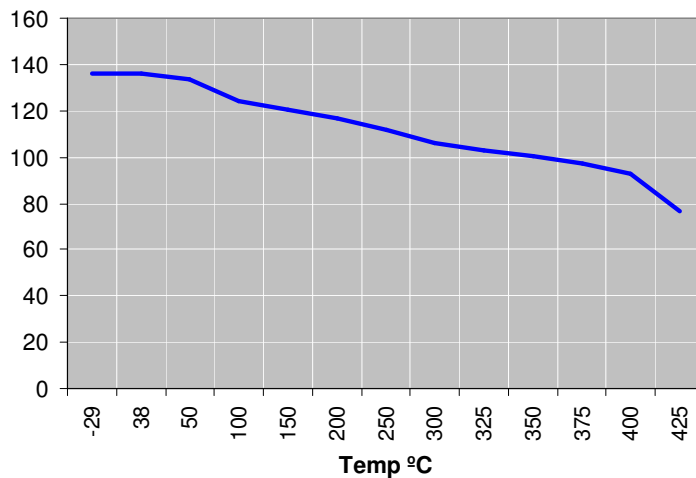

- A 105
- A 182 F316L

P Bar

