

ATTENTION

THIS DOCUMENT IS VALID IF AND ONLY IF YOU PERSONALLY DOWNLOADED IF FROM WWW.BRAY.COM
 IF YOU RECEIVED THIS DOCUMENT FROM ANY OTHER SOURCE, PLEASE TAKE INTO CONSIDERATION THAT ALTERATIONS
 COULD HAVE BEEN MADE, FOR AN ORIGINAL COPY, PLEASE CONTACT BRAY VALVE AT 281-894-5454

SERIES 31
ES12A-0014
Date: August 1993

Valve Size	A	B	C	D	E	F	BC	Top Plate Drilling		G	H	J	K	L	Lug BC	Bolting No. of Holes	Data Threads ISO-Coarse	Adapter Code	Weight (Kg.)
								No. of Holes	Hole Diameter										
50	94	43	51	72	140	90	70	4	10	14	10	32	30	58				A	3.0
65	106	46	64	85	152	90	70	4	10	14	10	32	46	65				A	3.5
80	124	46	76	102	159	90	70	4	10	14	10	32	63	71				A	4.0
100	154	52	102	131	178	90	70	4	10	16	11	32	89	104				B	7.0
125	181	56	127	156	190	90	70	4	10	19	13	32	116	117				C	9.0
150	206	56	146	178	203	90	70	4	10	19	13	32	137	129				C	10.5
200	267	60	197	240	241	150	125	4	14	22	16	32	189	154				D	19.0
250	324	68	248	291	273	150	125	4	14	30	22	51	240	195				E	30.0
300	378	78	298	342	311	150	125	4	14	30	22	51	290	229				E	40.0

Note: K dim is disc chordal dimension at valve face.

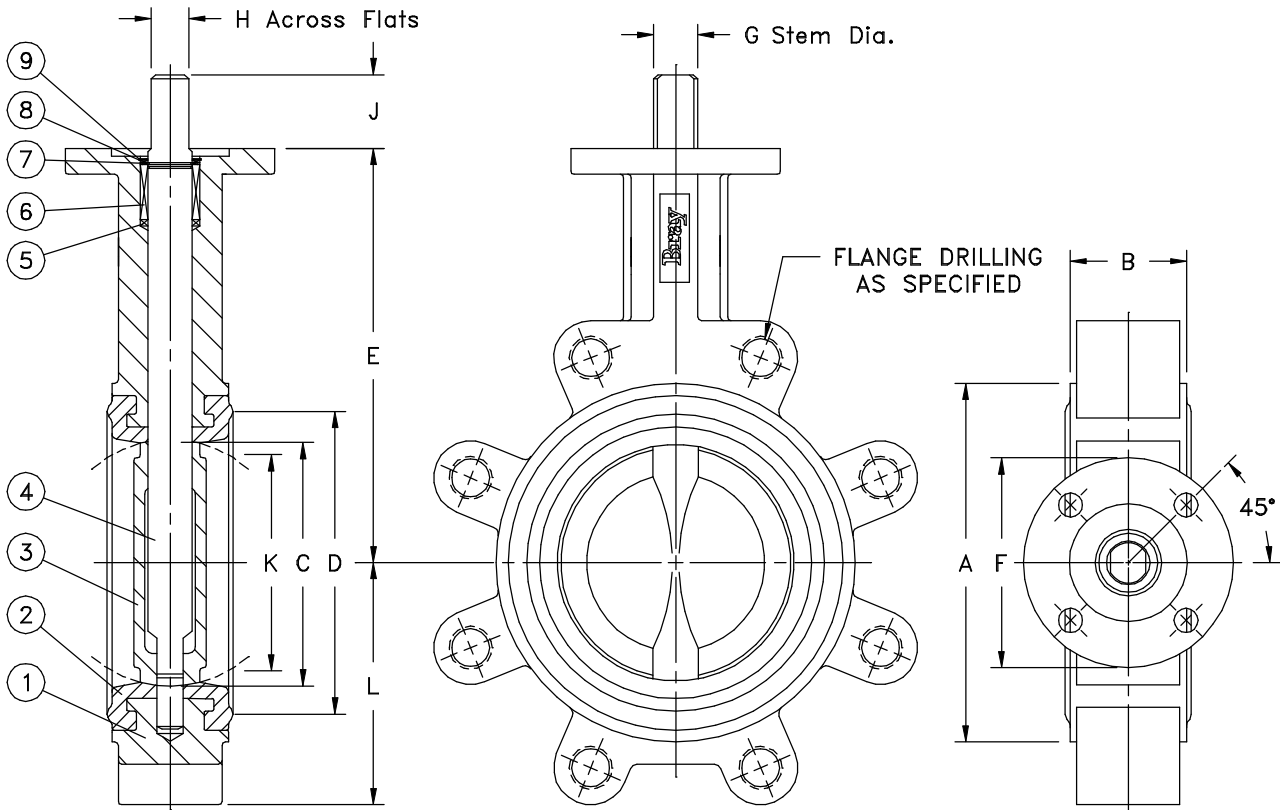

9	RETAINING RING	1			
8	THRUST WASHER	1			
7	STEM RETAINER	2			
6	BUSHING	1			
5	PACKING	1			
4	STEM	1			
3	DISC	1			
2	SEAT	1			
1	BODY	1			

ITEM No.	NAME	No. REQUIRED	SERIES/PART No.	MATERIAL	SPECIFICATION/REMARKS
----------	------	--------------	-----------------	----------	-----------------------

Valve Size _____ Flg. Drilling _____
 Pressure Rating _____
 Customer/Project _____
 Inq./P.O. No. _____
 Bray Order No. _____
 Certified Correct By _____ Date _____

The High Performance Company
BRAY VALVE & CONTROLS
 A Subsidiary of BRAY INTERNATIONAL, Inc.

PARTS LIST AND DIMENSIONS (Metric)
BUTTERFLY VALVE, SERIES 31 SIZES 50-300

Series	Size	Part No.	Material Trim Code	Drawing No.
				ES12A-0014

