

Electropneumatic positioners

SIPART PS2



6/2 Product Overview

	SIPART PS2
6/3	Technical description Technical specifications
6/8	- all versions
6/9	- SIPART PS2
6/11	- SIPART PS2 PA
6/13	- SIPART PS2 FF
6/15	- Add-on modules Ordering data
6/18	- SIPART PS2, PS2 PA, PS2 FF
6/20	- SIPART PS2 Ex d, PS2 Ex d PA, PS2 Ex d FF
6/21	- Accessories
6/23	Dimensional drawings
6/24	Schematics
6/25	Mounting kit



	Software
Sec. 9	SIMATIC PDM, for parametrize HART and PROFIBUS PA devices

You can download all instructions, catalogs and certificates for SIPART PS2 free of charge at the following Internet address:
www.siemens.com/positioners

Electropneumatic positioners

Product Overview

Overview

	Application	Description	Catalog page	Software for parameterization
Electropneumatic positioners				
	Position control of pneumatic linear or part-turn actuators, also for intrinsically safe operation	SIPART PS2 Universal device for positioning pneumatic actuators <ul style="list-style-type: none"> • Connection: 4 to 20 mA • HART; PROFIBUS PA or FOUNDATION Fieldbus • Local manual operation • Binary inputs and outputs • Diagnostic function • Blocking function • Automatic startup 	6/3	SIMATIC PDM
	As above, but in flameproof enclosure for explosion-proof application	SIPART PS2 As above, but in flameproof aluminum enclosure	6/3	SIMATIC PDM

Electropneumatic positioners

SIPART PS2

Technical description

Overview



SIPART PS2 electropneumatic positioner in Makrolon enclosure



SIPART PS2 Ex d electropneumatic positioner in flameproof aluminium enclosure (Ex d)



SIPART PS2 in stainless steel enclosure

The SIPART PS2 electropneumatic positioner is used to control the final control element of pneumatic linear or part-turn actuators. The electropneumatic positioner moves the actuator to a valve position corresponding to the setpoint. Additional function inputs can be used to block the valve or to set a safety position. A binary input is present as standard in the basic device for this purpose.

Benefits

SIPART PS2 positioners offer decisive advantages:

- Simple installation and automatic commissioning (self-adjustment of zero and span)
- Simple operation with
 - Local operation (manual operation) and configuration of the device using three buttons and a user-friendly two-line display
 - Programming through SIMATIC PDM
- Very high-quality control thanks to an online adaptation procedure
- Negligible air consumption in stationary operation
- "Tight shut-off" function (ensures maximum positioning pressure on the valve seat)
- Numerous functions can be activated by simple configuring (e.g. characteristic curves and limits)
- Extensive diagnostic functions for valve and actuator
- Only one device version for linear and part-turn actuators
- Few moving parts, hence insensitive to vibrations
- External non-contacting position sensor as option for extreme ambient conditions
- "Intelligent solenoid valve": Partial Stroke Test and solenoid valve function in a single device
- Partial Stroke Test e.g. for safety valves
- Can also be operated with natural gas
- SIL (Safety Integrity Level) 2

Application

The SIPART PS2 positioner is used, for example, in the following industries:

- Chemical/petrochemical
- Power stations
- Paper and glass
- Water, waste water
- Food and pharmaceuticals
- Offshore plants

The SIPART PS2 positioner is available:

- For single-acting actuators: In Makrolon, stainless steel or aluminium enclosure, as well as flameproof aluminum enclosure (Ex d)
- For double-action actuators: In Makrolon enclosure, stainless steel enclosure and flameproof aluminum enclosure (Ex d)
- For non-hazardous applications
- For hazardous applications in the versions
 - as intrinsically safe device (Ex ia/ib) or
 - in flameproof aluminum enclosure (Ex d) or
 - in Ex n design (non sparking)

and in the versions:

- With 0/4 ... 20 mA control with/without communication through HART signal
- With PROFIBUS PA communication interface
- With Foundation Fieldbus (FF) communications interface.

Electropneumatic positioners

SIPART PS2

Technical description

Explosion-proof versions

The basic version of the device is available in an intrinsically safe design with degree of protection Ex ia/ib and approval for zone 2/zone 20 (dust).

Operation in zone 1 is permissible for the SIPART PS2 Ex d version with flameproof enclosure (see "Technical Data"). It is then permissible to use all option modules (except external actuator travel detection systems, SIA/GWK modules and NCS).

In a flameproof enclosure for extreme ambient conditions

The SIPART PS2 is available in a stainless steel enclosure (with no window in the cover) for use in particularly aggressive environments (e.g. offshore operation, chlorine plants etc.). The device functions are the same as those of the basic versions.

Design

The SIPART PS2 positioner is a digital field device with a highly-integrated microcontroller.

The positioner consists of the following components:

- Enclosure and cover
- PCB with corresponding electronics with or without communication through HART or with electronics for communication in accordance with
 - PROFIBUS PA specification, IEC 61158-2; bus-supplied device, or
 - Foundation Fieldbus (FF) specification, IEC 61158-2, bus-supplied device
- Position detection system
- Terminal housing with screw terminals
- Pneumatic valve manifold with piezoelectric valve precontrol.

The valve manifold is located in the housing, the pneumatic connections for the inlet air and the positioning pressure on the right-hand side. A pressure gauge block and/or a safety solenoid valve can be connected there as options. The SIPART PS2 positioner is fitted to the linear or part-turn actuator using an appropriate mounting kit. The circuit board container in the casing provides slots for separately ordered boards with the following functions:

I_y module:

- Position feedback as a two-wire signal 4 to 20 mA

Alarm unit (3 outputs, 1 input):

- Signaling of two limits of the travel or angle by binary signals. The two limits can be set independently as maximum or minimum values.
- Output of an alarm if the setpoint position of the final control element is not reached in automatic mode or if a device fault occurs.
- Second binary input for alarm signals of for triggering safety reactions, e.g. blocking function or safety position.

Limit signaling through slot-type initiators (SIA module)

Two limits can be signaled redundantly as NAMUR signals (EN 60947-5-6) by slot-type initiators. An alarm output is also integrated in the module (see alarm unit).

Limit value signal via mechanical contacts (limit value contact module)

Two limits can be signaled redundantly by switching contacts. An alarm output is also integrated in the module (see alarm unit).

Valid for all modules described above:

All signals are electrically isolated from one another and from the basic unit. The outputs indicate self-signaling faults. The modules are easy to retrofit.

Separate mounting of actuator travel detection system and controller unit

The position detection system and controller unit can be connected separately for all casing versions of the SIPART PS2 (except flameproof design). Measurement of the travel or angle is carried out directly on the actuator. The controller unit can then be fitted a certain distance away, e.g. on a mounting pipe or similar, and is connected to the position detection system by an electric cable and to the actuator by one or two pneumatic lines. Such a split design is frequently advantageous if the ambient conditions at the fitting exceed the specified values for the positioner (e.g. strong vibrations).

The following can be used for measuring the travel or angle:

- NCS sensor
- External position detection system C73451-A430-D78
- A commercially available potentiometer (10 kΩ resistance), e.g. for higher application temperatures or customer-specific applications

The use of linear potentiometers is recommended for very small linear actuators with a short valve travel since, on the one hand, the space required by the linear potentiometer is very small and, on the other, the transmission characteristic is optimum for a small travel.

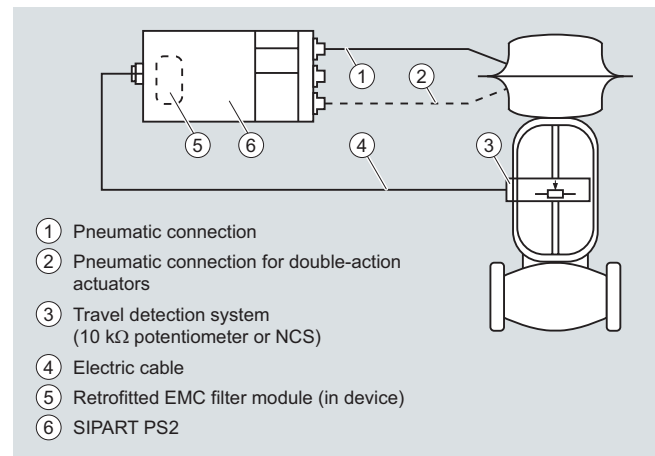

Separate mounting of positioner detection system and controller unit

Non-contacting position sensor (NCS)



Contact and non-contacting position sensor (NCS) for part-turn actuator (left) and for linear actuator ≤ 14 mm (0.55 inch) (right)

Electropneumatic positioners

SIPART PS2

Technical description



NCS for travels >14 mm (0.55 inch)

The NCS sensor consists of a non-contacting position sensor. All coupling elements are omitted such as coupling wheel and driver pin with part-turn actuators or lever and pick-up bracket with linear actuators for up to 14 mm (0.55 inch) travel.

This results in:

- Even greater resistance to vibration and shock
- No wear of sensor
- Problem-free mounting on very small actuators
- Negligible hysteresis with very small travels

The sensor does not require an additional power supply, i.e. SIPART PS2 (not for Ex d version) can be operated in a 2-wire system. The NCS (Non Contacting Position Sensor) consists of a potted sensor housing which must be mounted permanently and a magnet which is mounted on the spindle of linear actuators or on the shaft butt of part-turn actuators. For the version for travels >14 mm (0.55 inch), the magnet and the NCS are premounted on a stainless steel frame and offer the same interface mechanically as the positioner itself, i.e. they can be mounted using the standard mounting kits 6DR4004-8V, -8VK and -8VL.

The installation of a EMC filter module in the positioner (controller unit) is necessary in order to ensure a connection level with EMC according to EN 61326/A1 and NAMUR NE21 when using external sensors (see Selection and ordering data for "EMC filter module").

Function

The SIPART PS2 electropneumatic positioner works in a completely different way to normal positioners.

Mode of operation

Comparison of the setpoint and the actual value takes place electronically in a microcontroller. If the microcontroller detects a deviation, it uses a 5-way switch procedure to control the piezoelectric valves, which regulates the flow of air into and from the chambers of the pneumatic actuator or blows it in the opposite direction.

The microcontroller then outputs an electric control command to the piezoelectric valve in accordance with the size and direction of the system deviation (deviation between setpoint w and control output x). The piezoelectric valve converts the command into a pneumatic positional increment.

The positioner outputs a continuous signal in the area where there is a large system deviation (high-speed zone); in areas of moderate system deviation (slow-speed zone) it outputs a se-

quence of pulses. No positioning signals are output in the case of a small system deviation (adaptive or variable dead zone).

The linear or rotary motion of the actuator is detected by the mounting kit and transferred to a high-quality potentiometer made of plastic conductive material over a shaft and a non-floating gear transmission.

The angular error of the pick-up in cases where the assembly is mounted on a linear actuator is corrected automatically.

When connected in a 2-wire system, the SIPART PS2 draws its power exclusively from the 4 to 20 mA setpoint signal. The electric power is also connected through the 2-wire bus signal with PROFIBUS operation (SIPART PS2 PA). The same applies for the FOUNDATION Fieldbus version.

Pneumatic valve manifold with piezoelectric valve precontrol

The piezoelectric valve can release very short control pulses. This helps achieve a high positioning accuracy. The pilot element is a piezoelectric bending converter which switches the pneumatic main controller unit. The valve manifold is characterized by an extremely long service life.

Local operation

Local operation is performed using the built-in display and the three buttons. Switching between the operating levels Automatic, Manual, Configuring and Diagnosis is possible at the press of a button.

In Manual mode the drive can be adjusted over the entire range without interrupting the circuit.

Operation and monitoring with the SIMATIC PDM communications program

The SIMATIC PDM program is available for communication through the HART interface and also for the PROFIBUS PA coupling.

The SIMATIC PDM communication software allows for convenient remote operation and remote observation using a PC. The positioner can also be configured using this program. Parameters which provide important information for maintenance and fault diagnosis of the complete unit can also be determined using process data and comparison data.

When operating the SIPART PS2 through the HART interface, the connection is made directly to the 2-wire cable to the SIPART PS2 positioner through a HART modem that can be connected to the RS 232 or USB interface. The signals needed for communication in conformity with the HART protocol are superimposed on the current signal in accordance with the Frequency Shift Keying (FSK) method.

Automatic commissioning

With a simple configuration menu the SIPART PS2 can be quickly adapted to the fitting and adjusted by means of an automatic startup function.

During initialization, the microcontroller determines the zero point, full-scale value, the direction of action and the positioning speed of the fitting. From this data it establishes the minimum pulse time and the dead zone, thus optimizing the control.

Low air consumption

A hallmark of the SIPART PS2 is its own extremely low consumption of air. Normal air losses on conventional positioners are very costly. Thanks to the use of modern piezoelectric technology, the SIPART PS2 consumes air only when it is needed, which means that it pays for itself within a very short time.

Comprehensive monitoring functions

The SIPART PS2 has various monitoring functions with which changes on the actuator and valve can be detected and signaled if applicable when a selectable limit has been exceeded. This information may be important for diagnosis of the actuator

Electropneumatic positioners

SIPART PS2

Technical description

or valve. The measuring data to be determined and monitored, some of whose limits can be adjusted, include:

- Travel integral
- Number of changes in direction
- Alarm counter
- Self-adjusting dead zone
- Valve end limit position (e.g. for detection of valve seat wear or deposits)
- Operating hours (also according to temperature and travel ranges) as well as min./max. temperature
- Operating cycles of piezoelectric valves
- Valve positioning time
- Actuator leakages

Status monitoring with 3-stage alarm concept

The intelligent electropneumatic SIPART PS2 positioner is equipped with additional monitoring functions. The status indications derived from these monitoring functions signal active faults of the unit. The severity of these faults are graded using "traffic light signaling", symbolized by a wrench in the colors green, yellow and red (in SIMATIC PDM and Maintenance Station):

- Need for maintenance (green wrench)
- Urgent need for maintenance (yellow wrench)
- Imminent danger of unit failure or general failure (red wrench)

This allows users to put early measures into action before a serious valve or actuator fault occurs which could result in a system shutdown. The fact that a fault indication is signaled, such as the onset of a diaphragm break in the actuator or the progressive sluggishness of a unit, enables the user to ensure system reliability at any time by means of suitable maintenance strategies.

This three-stage alarm hierarchy also allows early detection and signaling of other faults, such as the static friction of a packing box, the wearing of a valve plug/seating, or precipitations or incrustations on the fittings.

These fault indications can be output either line-conducted over the alarm outputs (see above) of the positioner (max. 3), or via communication over the HART or field bus interfaces. In this case, the HART, PROFIBUS and FF versions of SIPART PS2 permit a differentiation of the various fault indications, as well as a trend representation and histogram function of all key process variables with regard to the fittings.

The display of the device also displays the graded maintenance requirements, complete with identification of the source of the fault.

Functional safety acc. to SIL 2

The SIPART PS2 positioners are also suitable for the control of fittings, which meet the special requirements of the functional safety up to SIL 2 to IEC 61508 or IEC 61511-1.

This is a single-action, venting positioner with an input of 4 to 20 mA, PROFIBUS PA and FOUNDATION Fieldbus (FF) for mounting on pneumatic actuators with spring return.

The positioner vents the valve actuator on demand/in the event of a fault and puts the valve in the preset safety position.

This positioner meets the following requirements:

- Functional safety up to SIL 2 to IEC 61508 or IEC 61511-1, from firmware version C4 or higher for safe venting
- Explosion protection for the versions 6DR5...-E...
- Electromagnetic compatibility to EN 61326/A1, Appendix A.1

SIPART PS 2 as "intelligent solenoid valve"

Open / Close valves, safety fittings in particular, are generally pneumatically controlled over a solenoid valve. If you use SIPART S2 instead of this type of solenoid valve, the positioner performs two tasks in a single device (without extra wiring)

- Firstly, it switches the fitting off on demand by venting the actuator (functional safety acc. to SIL 2 (see above))
- Secondly, it can perform a Partial Stroke Test at regular intervals (1 - 365 days), which prevents the blocking of the fitting, e.g. due to corrosion or furring.

As in this case SIPART PS2 is constantly working in normal operation (e.g. 99 % position), it also acts as a permanent test function for the pneumatic output circuit, which is not usually possible when using a solenoid valve.

Solenoid valves on control valves can also not normally be tested during operation. They are therefore not necessary when using SIPART PS2 with a 4-wire connection system as the venting is carried out on demand by SIPART PS2. This means that on control valves, both the control function and the shut-off function can be carried out by a single device.

Configuring

In configuring mode, the SIPART PS2 positioner can be configured to requirements and include the following settings:

- Input current range 0 to 20 mA or 4 to 20 mA
- Rising or falling characteristic curve at the setpoint input
- Positioning speed limit (setpoint ramp)
- Split-range operation; adjustable start-of-scale and full-scale values
- Response threshold (dead zone); self-adjusting or fixed
- Direction of action; rising or falling output pressure with rising setpoint
- Limits (start-of-scale and full-scale values) of positioning range
- Limits (alarms) of the final control element position; minimum and maximum values
- Automatic "tight shut-off" (with adjustable response threshold)
- The travel can be corrected in accordance with the valve characteristic curve.
- Function of binary inputs
- Function of alarm output etc.

Configuration of the various SIPART PS2 versions is largely identical.

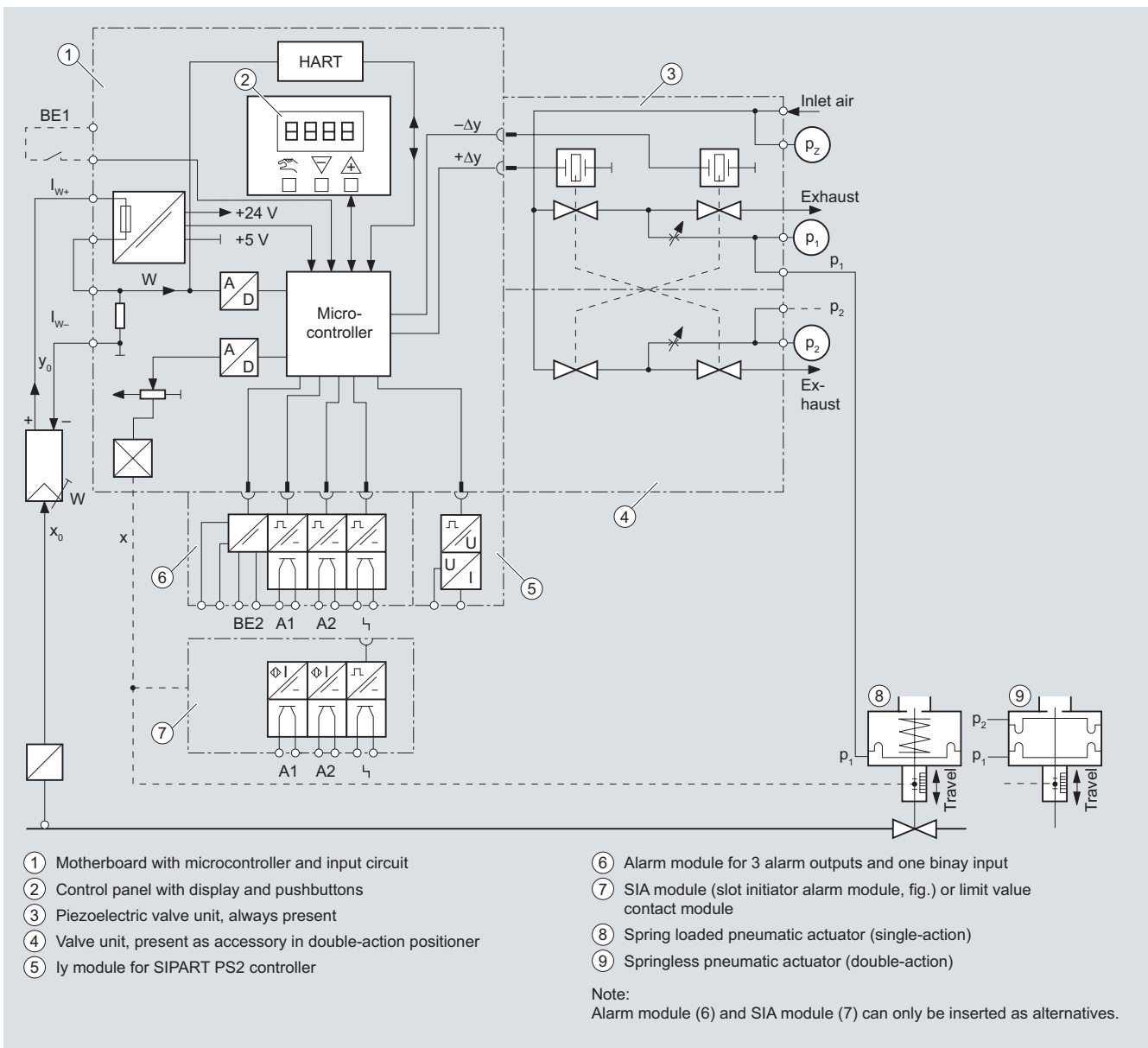

SIPART PS2, electropneumatic positioner, function diagram

Electropneumatic positioners

SIPART PS2

Technical specifications all versions

Technical specifications

SIPART PS2 (all versions)	
General data	
Range of stroke (linear actuators)	3 ... 130 mm (0.12 ... 5.12 inch) (angle of positioner shaft 16 ... 90°)
Angle of rotation (part-turn actuators)	30 ... 100°
Assembly	
• On linear actuators	Using mounting kit 6DR4004-8V and where necessary with an additional lever arm 6DR4004-8L on actuators according to IEC 534-6 (NAMUR) with ribs, bars or flat face
• On part-turn actuators	Using mounting kit 6DR4004-8D on actuators with mounting plane according to VDI/VDE 3845 and DIN 3337. The required mounting console has to be provided on the actuator side; shaft with groove and female thread M6
Controller unit	
• Five-point switch	Self-adjusting
• Deadband	
- dEbA = Auto	Self-adjusting or can be set as fixed value
- dEbA = 0.1 ... 10 %	Self-adjusting or can be set as fixed value
A/D converter	
• Scan time	10 ms
• Resolution	≤ 0.05 %
• Transmission error	≤ 0.2 %
• Temperature influence effect	≤ 0.1 %/10 K (≤ 0.1 %/18 °F)
Cycle time	
• 20 mA/HART device	20 ms
• PA device	60 ms
• FF device	60 ms (min. loop time)
Binary input BE1 (terminals 9/10; electrically conn. to basic device)	Suitable only for floating contact; max. contact load < 5 µA with 3 V
Degree of protection	IP66 to EN 60 529/NEMA 4X
EMC requirements	EN 61326/A1 Appendix A.1 and NAMUR NE21 August 98
Material	
• Enclosure	
- 6DR5..0-... (plastic)	Glass-fiber-reinforced Macrolon
- 6DR5..1-... (aluminum)	GD AISi12
- 6DR5..2-... (stainless steel)	Austenitic stainl. steel mat. No. 1.4581
- 6DR5..5-... (alum., press.-proof)	GK AISi12
• Pressure gauge block	Aluminium AIMgSi, anodized
Vibration resistance	
• Harmonic oscillations (sine-wave) according to EN 60068-2-6/05.96	3.5 mm (0.14 inch), 2 ... 27 Hz 3 cycles/axis 98.1 m/s ² (321.84 ft/s ²), 27 ... 300 Hz, 3 cycles/axis
• Bumping (half-sine) to EN 60068-2-29/03.95	150 m/s ² (492 ft/s ²), 6 ms, 1000 shocks/axis
• Noise (digitally controlled) to EN 60068-2-64/08.95	10 ... 200 Hz; 1 (m/s ²) ² /Hz (3.28 (ft/s ²) ² /Hz) 200 ... 500 Hz; 0.3 (m/s ²) ² /Hz (0.98 (ft/s ²) ² /Hz) 4 hours/axis
• Recommended continuous duty range of the complete fitting	≤ 30 m/s ² (≤ 98.4 ft/s ²) without resonance sharpness

Weight, basic device	
• Glass-fiber-reinforced Makrolon enclosure	Approx. 0.9 kg (1.98 lb)
• Aluminum enclosure	Approx. 1.3 kg (2.86 lb)
• Stainless steel enclosure	Approx. 3.9 kg (8.58 lb)
• Pressure-proof alum. enclosure	Approx. 5.2 kg (11.46 lb)
Dimensions	See Dimensional drawings
Climatic class	According to DIN EN 60721-3-4
• Storage ¹⁾	1K5, but -40 ... +80 °C (-40 ... +176 °F)
• Transport ¹⁾	2K4, but -40 ... +80 °C (-40 ... +176 °F)
• Operation ²⁾	4K3, but -30 ... +80 °C ³⁾ (-22 ... +176 °F)

Certificates and approvals

Classification according to pressure equipment directive (PED 97/23/EC)	For gases of fluid group 1, complies with requirements of article 3, par. 3 (sound engineering practice SEP)
CE marking	You can find the appropriate guidelines and standards applied, including the relevant versions, in the EC Declaration of Conformity on the Internet

Pneumatic data

Auxiliary power (air supply)	Compressed air, nitrogen or cleaned natural gas
• Pressure	1.4 ... 7 bar (20.3 ... 101.5 psi): Sufficiently greater than max. drive pressure (actuating pressure)
Air quality to ISO 8573-1	
• Solid particulate size and density	Class 2
• Pressure dew point	Class 2 (min. 20 K (36 °F) below ambient temperature)
• Oil content	Class 2
Unrestricted flow (DIN 1945)	
• Inlet air valve (ventilate actuator) ⁴⁾	
- 2 bar (29 psi)	4.1 Nm ³ /h (18.1 USgpm)
- 4 bar (58 psi)	7.1 Nm ³ /h (31.3 USgpm)
- 6 bar (87 psi)	9.8 Nm ³ /h (43.1 USgpm)
• Outlet air valve (vent actuator) ⁴⁾	
- 2 bar (29 psi)	8.2 Nm ³ /h (36.1 USgpm)
- 4 bar (58 psi)	13.7 Nm ³ /h (60.3 USgpm)
- 6 bar (87 psi)	19.2 Nm ³ /h (84.5 USgpm)
Valve leakage	< 6·10 ⁻⁴ Nm ³ /h (0.0026 USgpm)
Throttle ratio	Adjustable up to ∞ : 1
Auxiliary power consumption in the controlled state	< 3,6·10 ⁻² Nm ³ /h (0.158 USgpm)
Device versions	
• In Makrolon enclosure	Single-acting and double-acting
• In aluminum enclosure	Single-acting
• In pressure-proof aluminum encl.	Single-acting and double-acting
• In stainless steel enclosure	Single-acting and double-acting

- ¹⁾ During commissioning at ≤ 0 °C (≤ 32 °F) make sure that the valves are flushed long enough with the dry medium.
- ²⁾ At ≤ -10 °C (≤ 14 °F) the display refresh rate of the indicator is limited. Only T4 is permissible when using I_y module.
- ³⁾ -20 ... +80 °C (-4 ... + 176 °F) for 6DR55..-0G..., 6DR56..-0G..., 6DR55..-0D... and 6DR56..-0D...
- ⁴⁾ With the Ex d version (6DR5..5-...) the values are reduced by approx. 20 %

Gauge made of	Plastic	Steel	Stainl. Steel 316
Degree of protection	IP31	IP44	IP54
Vibration resistance	acc. to DIN EN 837-1		

Technical specifications

SIPART PS2	Basic device without Ex protection	Basic device with Ex d protection (flameproof enclosure)	Basic device with Ex ia/ib protection	Basic device with Ex n/ dust protection
Explosion protection ATEX	-	Ex d II 2 G Ex d II C T6	Ex ia/ib II 2 G Ex ia/ib II C T6	Ex n II 3 G Ex nA nL[nL] IIC T6 Dust II 3 D Ex tD A22 IP66 T100°C
Mounting location	-		Zone 1	Zone 2/22
Permissible ambient temperature for operation	-30 ... +80 °C (-22 ... +176 °F)		T4: -30 ... +80 °C (-22 ... +176 °F) T5: -30 ... +65 °C (-22 ... +149 °F) T6: -30 ... +50 °C (-22 ... +122 °F)	
At ≤ -10 °C (+14 °F) the display refresh rate of the indicator is limited. (for basic devices with EX ia/ib and Ex n protection the following applies: Only T4 is permissible when using I _y module)				
Electrical specifications				
Input				
<u>2-wire connection (terminals 6/8)</u>				
Rated signal range			4 ... 20 mA	
Current to maintain the auxiliary power supply			≥ 3.6 mA	
Required load voltage U _B (corresponds to Ω at 20 mA)				
• Without HART (6DR50..)				
- Typical		6.36 V (corresponds to 318 Ω)		7.8 V (corresponds to 390 Ω)
- max.		6.48 V (corresponds to 324 Ω)		8.3 V (corresponds to 415 Ω)
• Without HART (6DR53..)				
- Typical	7.9 V (corresponds to 395 Ω)			-
- max.	8.4 V (corresponds to 420 Ω)			-
• With HART (6DR51..)				
- Typical		6.6 V (corresponds to 330 Ω)		-
- max.				-
• With HART (6DR52..)				
- Typical			8.4 V (corresponds to 420 Ω)	
- max.			8.8 V (corresponds to 440 Ω)	
• Static destruction limit		± 40 mA		
Internal capacitance C _i				
• Without HART			22 nF	22 nF (at "nL")
• With HART			7 nF	7 nF (at "nL")
Internal inductance L _i				
• Without HART			0.12 mH	0.12 mH (at "nL")
• With HART			0.24 mH	0.24 mH (at "nL")
For connection to circuits with the following peak values			intrinsically safe U _i = 30 V DC I _i = 100 mA P _i = 1 W	at "nA" and "tD": U _n = 30 V DC I _n = 100 mA at "nL": U _i = 30 V DC I _i = 100 mA

Electropneumatic positioners

SIPART PS2

Technical specifications

SIPART PS2

SIPART PS2	Basic device without Ex protection	Basic device with Ex d protection (flameproof enclosure)	Basic device with Ex ia/lb protection	Basic device with Ex n/ dust protection
3-/4-wire device (terminals 2/4 and 6/8) (6DR52... and 6DR53...) <ul style="list-style-type: none"> • Power supply U_H • Current consumption I_H • Internal capacitance C_i • Internal inductance L_i • For connection to circuits with the following peak values 	18 ... 35 V DC	$(U_H - 7.5 \text{ V})/2,4 \text{ k}\Omega$ [mA]	18 ... 30 V DC	
Current input I_W				
Rated signal range			0/4 ... 20 mA	
Load voltage at 20 mA	$\leq 0.2 \text{ V}$ (corresponds to 10 Ω)			$\leq 1 \text{ V}$ (corresponds to 50 Ω)
Internal capacitance C_i	–		22 nF	22 nF (at "nL")
Internal inductance L_i	–		0.12 mH	0.12 mH (at "nL")
For connection to circuits with the following peak values	–		intrinsically safe $U_i = 30 \text{ V DC}$ $I_i = 100 \text{ mA}$ $P_i = 1 \text{ W}$	at "nA" and "nD": $U_n = 30 \text{ V DC}$ $I_n = 100 \text{ mA}$ at "nL": $U_i = 30 \text{ V DC}$ $I_i = 100 \text{ mA}$
Electrical isolation	between U_H and I_W		between U_H and I_W (2 intrinsically safe circuits)	between U_H and I_W
Test voltage			840 V DC, (1 s)	
Connections				
• Electrical	Screw terminals 2.5 AWG28-12 Cable gland M20x1.5 or 1/2-14 NPT	Screw terminals 2.5 AWG28-12 Ex d certified cable gland M20x1.5, 1/2-14 NPT or M25x1.5		Screw terminals 2.5 AWG28-12 Cable gland M20x1.5 or 1/2-14 NPT
• Pneumatic				
External position sensor (potentiometer or NCS; as option) with the following peak values				
• U_o	–			5 V
• I_o (static)	–			75 mA
• I_s (short-time)	–		160 mA	–
• P_o	–			120 mW
Maximum permissible external capacitance C_o	–			1 μF
Maximum permissible external inductance L_o	–			1 mH

Technical specifications

SIPART PS2 PA	Basic device without Ex protection	Basic device with Ex d protection (flameproof enclosure)	Basic device with Ex ia/ib protection	Basic device with Ex n/ dust protection
Explosion protection as per ATEX	Without	Ex d II 2 G Ex d II C T4/T5/T6	Ex ia/ib II 2 G Ex ia/ib II C T6	Ex n II 3 G Ex nA nL[nL] IIC T6 Dust II 3 D Ex tD A22 IP66 T100°C
Mounting location		Zone 1		Zone 2/22
Permissible ambient temperature for operation	-30 ... +80 °C (-22 ... +176 °F)	T4: -30 ... +80 °C (-22 ... +176 °F)	T5: -30 ... +65 °C (-22 ... +149 °F)	T4: -20 ... +75 °C (-4 ... +167 °F)
At ≤ -10 °C (+14 °F) the display refresh rate of the digital display is limited. (for basic devices with Ex protection the following applies: Only T4 is permissible when using I _y module.)		T6: -30 ... +50 °C (-22 ... +122 °F)		T5: -20 ... +65 °C (-4 ... +149 °F)
				T6: -20 ... +50 °C (-4 ... +122 °F)
Electrical specifications				
Input				
Power supply (terminals 6/7)	Bus-supplied			
Bus voltage	9 ... 32 V		9 ... 24 V	9 ... 32 V
• Bus connection with supply unit	–		Intrinsically safe FISCO	at "nA" and "tD": U _n = 32 V DC at "nL": FNICO
- Max. supply voltage U _o	–			17.5 V
- Max. short-circuit current I _o	–		380 mA	570 mA
- Max. power P _o	–		5.32 W	–
• Bus connection with barrier			intrinsically safe	at "nL"
- Max. supply voltage (U _o)	–		24 V	32 V
- Max. short-circuit current (I _o)	–		250 mA	–
- Max. power P _o	–		1.2 W	–
Current consumption			11.5 mA ± 10 %	
Additional error signal			0 mA	
Effective internal inductance L _i	–		8 μH	8 μH (at "nL")
Effective Internal capacitance C _i	–		Negligible	
Safety shutdown can be activated with coding bridge (terminals 81/82; electrically isolated from the basic device)				
• Input resistance			> 20 kΩ	
• Signal status "0" (shutdown active)			0 ... 4.5 V or unused	
• Signal status "1" (shutdown not active)			13 ... 30 V	
• Effective Internal capacitance C _i	–			Negligible
• Effective internal inductance L _i	–			Negligible
• For connection to power supply with	–		intrinsically safe	At "nA", "nL" and "tD"
- Max. supply voltage U _i	–		30 V	30 V
- Max. short-circuit current I _i	–		100 mA	100 mA
- Maximum power P _i	–		1 W	–
Electrical isolation	Between basic device and the input for safety shutdown, as well as the outputs of the option modules		The basic device and the input to the safety shutdown, as well as the outputs of the option modules, are separate, intrinsically safe circuits	Between basic device and the input for safety shutdown, as well as the outputs of the option modules
Test voltage			840 V DC, 1 s	

Electropneumatic positioners

SIPART PS2

Technical specifications SIPART PS2 PA

SIPART PS2 PA	Basic device without Ex protection	Basic device with Ex d protection (flameproof enclosure)	Basic device with Ex ia/lb protection	Basic device with Ex n/ dust protection
Communication C2 connections Device profile Response time to master message Device address PC parameterizing software	Layers 1 and +2 according to PROFIBUS PA, transmission technology according to IEC 1158-2; slave function; layer 7 (protocol layer) according to PROFIBUS DP, EN 50170 standard with the extended PROFIBUS functions (all data acyclic, manipulated variable, feedbacks and status also cyclic) Four connections to master class 2 are supported, automatic connection setup 60 s after break in communication PROFIBUS PA profile B, version 3.0, more than 150 objects Typically 10 ms 126 (when delivered) SIMATIC PDM, supports all device objects. The software is not included in the scope of delivery			
Connections <ul style="list-style-type: none"> Electrical <ul style="list-style-type: none"> Pneumatic External position sensor (potentiometer or NCS; as option) with the following peak values <ul style="list-style-type: none"> U_o I_o (static) I_s (short-time) P_o Maximum permissible external capacitance C_o Maximum permissible external inductance L_o 	Screw terminals 2.5 AWG28-12 Cable gland M20x1.5 or ½-14 NPT	Screw terminals 2.5 AWG28-12 Ex d certified cable gland M20x1.5, ½-14 NPT or M25x1.5	Screw terminals 2.5 AWG28-12 Cable gland M20x1.5 or ½-14 NPT Female thread G¼ EN ISO 228-1 (¼ -18 NPT)	5 V 75 mA 160 mA 120 mW 1 µF 1 mH

Technical specifications

SIPART PS2 FF	Basic device without Ex protection	Basic device with Ex d protection (flameproof enclosure)	Basic device with Ex ia/ib protection	Basic device with Ex n/ dust protection
Explosion protection as per ATEX	Without	Ex d II 2 G Ex d II C T4/T5/T6	Ex ia/ib II 2 G Ex ia/ib II C T6	Ex n II 3 G Ex nA nL[nL] IIC T6 Dust II 3 D Ex tD A22 IP66 T100°C
Mounting location		Zone 1		Zone 2/22
Permissible ambient temperature for operation	-30 ... +80 °C (-22 ... +176 °F)	T4: -30 ... +80 °C (-22 ... +176 °F) T5: -30 ... +65 °C (-22 ... +149 °F) T6: -30 ... +50 °C (-22 ... +122 °F)		T4: -20 ... +75 °C (-4 ... +167 °F)
At ≤ 10 °C (+14 °F) the display refresh rate of the indicator is limited (for basic devices with Ex protection the following applies: Only T4 is permissible when using I _y module.)				
Electrical specifications				
Input			Bus-supplied	
Power supply (terminals 6/7)				
Bus voltage	9 ... 32 V		9 ... 24 V	9 ... 32 V
• Bus connection with supply unit	–		Intrinsically safe FISCO	at "nA" and "tD": U _n = 32 V DC at "nL": FNICO
- Max. supply voltage U _o	–			17.5 V
- Max. short-circuit current I _o	–		380 mA	570 mA
- Max. power P _o	–		5.32 W	–
• Bus connection with barrier			intrinsically safe	at "nL"
- Max. supply voltage (U _o)	–		24 V	32 V
- Max. short-circuit current (I _o)	–		250 mA	–
- Max. power P _o	–		1.2 W	–
Electrical specifications				
Current consumption			10.5 mA ± 10 %	
Additional error signal			0 mA	
Effective internal inductance L _i	–		8 μH	8 μH (at "nL")
Effective Internal capacitance C _i	–			Negligible
Safety shutdown can be activated with coding bridge (terminals 81/82; electrically isolated from the basic device)				
• Input resistance			> 20 kΩ	
• Signal status "0" (shutdown active)			0 ... 4.5 V or unused	
• Signal status "1" (shutdown not active)			13 ... 30 V	
• Effective Internal capacitance C _i	–			Negligible
• Effective internal inductance L _i	–			Negligible
• For connection to power supply with	–		intrinsically safe	At "nA", "nL" and "tD"
- Max. supply voltage U _i	–			30 V
- Max. short-circuit current I _i	–			100 mA
- Maximum power P _i	–		1 W	–
Electrical isolation	Between basic device and the input for safety shutdown, as well as the outputs of the option modules		The basic device and the input to the safety shutdown, as well as the outputs of the option modules, are separate, intrinsically safe circuits	Between basic device and the input for safety shutdown, as well as the outputs of the option modules
Test voltage			840 V DC, 1 s	

Electropneumatic positioners

SIPART PS2

Technical specifications SIPART PS2 FF

SIPART PS2 FF	Basic device without Ex protection	Basic device with Ex d protection (flameproof enclosure)	Basic device with Ex ia/lb protection	Basic device with Ex n/ dust protection
Communication Communications group and class Function blocks Execution times of the blocks Physical layer profile FF registration Device address	According to technical specification of the Fieldbus Foundation for H1 communication Group 3, Class 31PS (publisher, subscriber) 1 resource block (RB2) 1 analog output function block (AO) 1 PID function block (PID) 1 transducer block (standard advanced positioner valve) AO: 60 ms PID: 80 ms 123, 511 Tested with ITK 5.0 22 (when delivered)			
Connections <ul style="list-style-type: none"> Electrical Screw terminals 2.5 AWG28-12 Cable gland M20x1.5 or ½-14 NPT	Screw terminals 2.5 AWG28-12 Cable gland M20x1.5 or ½-14 NPT	Screw terminals 2.5 AWG28-12 Ex d certified cable gland M20x1.5, ½-14 NPT or M25x1.5 Female thread G¼ EN ISO 228-1 (¼ -18 NPT)	Screw terminals 2.5 AWG28-12 Cable gland M20x1.5 or ½-14 NPT	
<ul style="list-style-type: none"> Pneumatic External position sensor (potentiometer or NCS; as option) with the following peak values				
<ul style="list-style-type: none"> U_o I_o (static) I_s (short-time) P_o Maximum permissible external capacitance C_o Maximum permissible external inductance L_o 	– – – – – –	– – – – – –	5 V 75 mA 160 mA – 120 mW 1 µF 1 mH	

Technical specifications

Add-on modules	Without Ex protection/ with Ex d protection	With Ex ia/ib protection	With Ex n/dust protection
Ex protection acc. to ATEX	–	II 2G Ex ia/ib II C T4/T5/T6 ¹⁾	Ex n II 3 G Ex nA nL[nL] IIC T6 Dust II 3 D Ex tD A22 IP66 T100°C
Mounting location	–	Zone 1	Zone 2/22
Permissible ambient temperature for operation (For devices with Ex protection: Only in conjunction with the basic device 6DR5...-E.... Only T4 permissible when using I _y module.)	-30 ... +80 °C (-22 ... +176 °F)	T4: -30 ... +80 °C (T4: -22 ... +176 °F) T5: -30 ... +65 °C (-22 ... +149 °F) T6: -30 ... +50 °C (-22 ... +122 °F)	
Alarm unit	6DR4004-8A		
Binary alarm outputs A1, A2 and alarm output			
<ul style="list-style-type: none"> • Signal status High (not responded) • Signal status Low* (responded) (* Low is also the status when the basic device is faulty or has no electric power supply) 	Conductive, R = 1 kΩ, +3/1 %* Disabled, I _R < 60 μA (* When used in the flameproof enclosure the current consumption must be limited to 10 mA per output.)	≥ 2.1 mA ≤ 1.2 mA (Switching threshold with supply to EN 60947-5-6: U _H = 8.2 V, R _i = 1 kΩ)	
<ul style="list-style-type: none"> • Internal capacitance C_i • Internal inductance L_i • Power supply U_H • Connecting to circuits with the following peak values 	– – ≤ 35 V –	5.2 nF Intrinsically safe switching amplifier to EN 60947-5-6 U _i = 15.5 V DC I _i = 25 mA P _i = 64 mW	5.2 nF (at "nL") Negligible – at "nA" and "tD": U _n = 15.5 V DC at "nL": U _i = 15.5 V DC I _i = 25 mA
Binary input BE2			
<ul style="list-style-type: none"> • Electrically connected to the basic device <ul style="list-style-type: none"> - Signal status 0 - Signal status 1 - Contact load • Electrically isolated from the basic device <ul style="list-style-type: none"> - Signal status 0 - Signal status 1 - Natural resistance • Static destruction limit • Internal inductance and capacitance • Connecting to circuits with the following peak values 	± 35 V – –	Floating contact, open Floating contact, closed 3 V, 5 mA ≤ 4.5 V or open ≥ 13 V ≥ 25 kΩ	Negligible – at "nA" and "tD": U _n = 25.2 V DC at "nL": U _i = 25.2 V DC
Electrical isolation	The 3 outputs, the input BE2 and the basic device are electrically isolated from each other		
Test voltage	840 V DC, 1 s		

¹⁾ Only in conjunction with the basic device 6DR5...-E.... Only T4 permissible when using with I_y module.

Electropneumatic positioners

SIPART PS2

Technical specifications

Add-on modules

Technical specifications

Add-on modules	Without Ex protection/ with Ex d protection	With Ex ia/ib protection	With Ex n/dust protection
SIA module Limit transmitter with slot-type initiators and alarm output <u>Limit transmitter A1, A2</u> Ex protection Connection 2 slot-type initiators Function Connecting to circuits with the following peak values Internal capacitance C_i Internal inductance L_i Electrical isolation Test voltage <u>Alarm output</u> Connection Signal state High (not activated) Signal state Low (activated) Internal capacitance C_i Internal inductance L_i Power supply U_H Connecting to circuits with the following peak values	6DR4004-8G (not for Ex d version) Without NC (normally closed) rated voltage 8 V Current consumption: ≥ 3 mA (limit value not responded) ≤ 1 mA (limit value responded)	6DR4004-6G 2-wire connection II 2 G Ex ia/ib IIC T6 Intrinsically safe switching amplifier EN 60947-5-6 $U_i = 15.5$ V DC $I_i = 25$ mA $P_i = 64$ mW 41 nF 100 μ H	II 3 G Ex nA nL [nL] IIC T6 at "nA" and "tD": $U_n = 15.5$ V DC $P_n = 64$ mW at "nL": $U_i = 15.5$ V DC $I_i = 25$ mA 41 nF (at "nL") 100 μ H (at "nL")
	The 3 outputs are electrically isolated from the basic device 840 V DC, 1 s		
	To switching amplifier according to EN 60947-5-6 (NAMUR), $U_H = 8.2$ V, $R_i = 1$ k Ω		
	$R = 1.1$ k Ω $R_i = 10$ k Ω – – $U_H \leq 35$ V DC $I \leq 20$ mA –	– 5.2 nF – – Intrinsically safe switching amplifier acc. to EN 60947-5-6 $U_i = 15.5$ V DC $I_i = 25$ mA $P_i = 64$ mW	≥ 2.1 mA ≤ 1.2 mA 5.2 nF (at "nL") Negligible – at "nA" and "tD": $U_n = 15.5$ V DC at "nL": $U_i = 15.5$ V DC $I_i = 25$ mA
Limit value contact module Limit transmitter with mechanical ground contact and alarm output <u>Limit transmitter A1, A2</u> Ex protection Max. switching current AC/DC Max. switching voltage AC/DC Internal capacitance Internal inductance Electrical isolation Test voltage <u>Alarm output</u> Connection Signal state High (not activated) Signal state Low (activated) Internal capacitance C_i Internal inductance L_i Power supply U_H Connecting to circuits with the following peak values	6DR4004-8K (not for Ex d version) Without 4 A 250 V/24 V – – $U_H \leq 35$ V DC $I \leq 20$ mA –	II 2 G Ex ia/ib IIC T6 Connection to intrinsically safe circuit with maximum values: $U_i = 30$ V, $I_i = 100$ mA, $P_i = 750$ mW 30 V DC Negligible Negligible	II 3 G Ex nL [nL] IIC T6 Connection to circuits with maximum values: at "nL": $U_i = 30$ V $I_i = 100$ mA, 30 V DC Negligible Negligible
	The 3 outputs are electrically isolated from the basic device 3150 V DC, 2 s		
	To switching amplifier according to EN 60947-5-6 (NAMUR), $U_H = 8.2$ V, $R_i = 1$ k Ω		
	$R = 1.1$ k Ω $R_i = 10$ k Ω – – $U_H \leq 35$ V DC $I \leq 20$ mA –	– 5.2 nF – – Intrinsically safe switching amplifier acc. to EN 60947-5-6 $U_i = 15.5$ V DC $I_i = 25$ mA $P_i = 64$ mW	≥ 2.1 mA ≤ 1.2 mA 5.2 nF (at "nL") Negligible – at "nL": $U_i = 15.5$ V DC $I_i = 25$ mA

Electropneumatic positioners

SIPART PS2

Technical specifications

Add-on modules

Add-on modules	Without Ex protection/ with Ex d protection	With Ex ia/ib protection	With Ex n protection
I_y module	6DR4004-8J	6DR4004-6J	
DC output for position feedback		2-wire connection	
Rated signal range		4 ... 20 mA, short-circuit-proof	
Total operating range		3.6 ... 20.5 mA	
Power supply U _H	+12 ... +35 V	+12 ... +30 V	
External loads R _B [kΩ]		≤ (U _H [V] - 12 V) / i [mA]	
Transmission error		≤ 0,3 %	
Temperature influence effect		≤ 0.1 %/10 K (≤ 0.1 %/18 °F)	
Resolution		≤ 0,1 %	
Residual ripple		≤ 1 %	
Internal capacitance C _i	—	11 nF	11 nF (at "nL")
Internal inductance L _i	—		Negligible
For connection to circuits with the following peak values		Intrinsically safe: U _i = 30 V DC I _i = 100 mA P _i = 1 W (only T4)	at "nA" and "tD": U _n = 30 V DC I _n = 100 mA P _n = 1 W (only T4) at "nL": U _i = 30 V DC I _i = 100 mA
Electrical isolation		Electrically isolated from the basic device	
Test voltage		840 V DC, 1 s	
NCS sensor	(not for Ex d version)		
Position range			
• Linear actuator	3 ... 130 mm (0.12 ... 5.12 inch), to 200 mm (7.87 inch) on request	3 ... 130 mm (0.12 ... 5.12 inch), to 200 mm (7.87 inch) on request	—
• Part-turn actuator	30° ... 100° (not for Ex d version)	30° ... 100°	—
Linearity (after correction by SIPART PS2)			
• Linear actuator	± 1 %	± 1 %	—
• Part-turn actuator	± 1 %	± 1 %	—
Hysteresis	± 0.2 %	± 0.2 %	—
Continuous working temperature	-40 °C ... +85 °C (-40 °F ... +185 °F), extended temperature range on request	-40 °C ... +85 °C (-40 °F ... +185 °F), extended temperature range on request	—
Vibration resistance Harmonic oscillations (sine-wave) according to EN 60062-2-6/05.96		7 mm (0.28 inch), 5 ... 54 Hz 500 m/s ² (1640 ft/s ²), 80 ... 200 Hz	
For connection to circuits with the following peak values		Intrinsically safe U _i = 5 V DC	at "nL": U _i = 5 V DC
Internal capacitance C _i	—	10 nF	10 nF (at "nL")
Internal inductance L _i	—	240 μH	240 μH (at "nL")
Degree of protection of enclosure		IP68/NEMA 4X	

Electropneumatic positioners

SIPART PS2

Ordering data

SIPART PS2, PS2 PA, PS2 FF

Selection and ordering data	Order No.
SIPART PS2 electropneumatic positioner, without Ex protection, Ex ia/ib and Ex n	6 DR 5 - 0 - A
Version	
2-wire (4 to 20 mA)	
• <u>Without</u> HART	0
• <u>With</u> HART, <u>not</u> explosion-protected	1
2-, 3-, 4-wire (0/4 to 20 mA)	
• <u>With</u> HART, explosion-protected	2
• <u>Without</u> HART, <u>not</u> explosion-protected	3
PROFIBUS PA connection	5
FOUNDATION Fieldbus connection	6
For actuator	
Single-action	1
Double-action	2
Enclosure	
Makrolon	0
Aluminum; only single-action	1 1
Stainless steel (without window)	2
Explosion protection	
Without	
With explosion protection Ex ia/ib (CENELEC/FM/CSA)	N
With explosion protection Ex n (CENELEC/ATEX)	E
• For zone 2 and zone 22 (dust) Enclosure: Aluminum or stainless steel, each without inspection window in the cover	D
• For zone 2 ¹⁾²⁾ Enclosure: Aluminum or Makrolon, each with inspection window in the cover	G
Connection thread electrical/pneumatic	
M20 x 1.5 / G¼	G
½-14 NPT / ¼-18 NPT ³⁾	N
M20 x 1.5 / ¼-18 NPT	M
½-14 NPT / G¼ ³⁾	P
With plug M12 / G¼	R
With plug M12 / ¼-18 NPT	S
Limit monitor	
Installed, incl. 2nd cable gland	
Without	0
Alarm module; electronic (6DR4004-.A)	1
SIA module; slot-type initiators (6DR4004-.G)	2
Limit value contact module (mechanical switching contacts (6DR4004-.K)	3

Selection and ordering data	Order No.
SIPART PS2 electropneumatic positioner, without Ex protection, Ex ia/ib and Ex n	6 DR 5 - 0 - A
Option modules	
Installed, incl. 2nd cable gland	
Without	0
ly module for position feedback signal (4 ... 20 mA) (6DR4004-.J)	1
EMC filter module for external position sensor in the SIPART PS2 enclosure (C73451-A430-D23), NCS sensor 6DR4004-8/6NN1/2/30 and external position sensing with non-Siemens potentiometer	2
ly module and EMC filter module for external position sensor	3
Customer-specific design	
Without	0
Brief instructions	
German/English	A
French/Spanish/Italian	B
Mounted pressure gauge block	
Without	0
Single-action G¼, scaled in MPa and bar	1
Double-action G¼, scaled in MPa and bar	2
Single-action ¼-18 NPT, scaled in MPa and psi	3
Double-action ¼-18 NPT, scaled in MPa and psi	4
Double-action ¼-18 NPT, scaled in MPa and psi	9
Further designs	Order code
Add "-Z" to Order No. and specify Order Code.	
Gauge made of steel, Aluminium block, single-action G¼, scaled in MPa, bar and psi	R1A ⁴⁾
Gauge made of steel, Aluminium block, double-action G¼, scaled in MPa, bar and psi	R2A ⁴⁾
Gauge made of steel, Aluminium block, single-action ¼-18 NPT, scaled in MPa, bar and psi	R1B ⁴⁾
Gauge made of steel, Aluminium block, double-action ¼-18 NPT, scaled in MPa, bar and psi	R2B ⁴⁾
Gauge made of stainless steel 316, stainless steel block 316, single-action G¼, scaled in MPa, bar and psi	R1C ⁴⁾
Gauge made of stainless steel 316, stainless steel block 316, double-action G¼, Skalierung MPa, bar, psi	R2C ⁴⁾
Manometer aus Edelstahl 316, stainless steel block 316, single-action ¼-18 NPT, scaled in MPa, bar and psi	R1D ⁴⁾
Gauge made of stainless steel 316, stainless steel block 316, double-action ¼-18 NPT, scaled in MPa, bar and psi	R2D ⁴⁾
Pneumatic terminal strip made of stainless steel 316 for device with Makrolon enclosure	K18 ⁴⁾
Version with stainless steel sound absorbers Standard with stainless steel enclosure	A40

Selection and ordering data	Order No.
SIPART PS2 electropneumatic positioner, without Ex protection, Ex ia/ib and Ex n	6 DR 5 - 0 - A
Measuring point number (TAG No.) Max. 8 characters for HART, max. 32 characters for PROFIBUS PA, FOUNDATION Fieldbus and 4 ... 20 mA, specify in plain text: Y17:	Y17 ⁵⁾
Measuring point description Max. 16 characters for HART, max. 32 characters for PROFIBUS PA, FOUNDATION Fieldbus and 4 ... 20 mA, specify in plain text: Y15:	Y15 ⁵⁾
Measuring point text Max. 24 characters for HART, max. 32 characters for PROFIBUS PA, FOUNDATION Fieldbus and 4 ... 20 mA, specify in plain text: Y16:	Y16 ⁵⁾
TAG plate made of stainless steel, 3-line Text line 1: Plain text from Y17 Text line 2: Plain text from Y15 Text line 3: Plain text from Y16	A20 ⁵⁾
Preset bus address Specify in plain text: Y25:	Y25 ⁵⁾
(only for 6DR55.. and 6DR56..)	

► Available ex stock (select combinations)

- 1) Maximum impact energy on the enclosure: 1 Joule.
- 2) For device versions in Makrolon enclosure: it is essential to prevent electrostatic charging.
Maximum torque on the cable gland: 67 Nm.
- 3) Connection thread, electrical using NPT adapter on Makrolon and aluminum enclosure.
- 4) Available in April 2010
- 5) Only for Makrolon enclosure, for other enclosures on request.

Electropneumatic positioners

SIPART PS2

Ordering data

SIPART PS2 Ex d, PS2 Ex d PA, PS2 Ex d FF

Selection and ordering data	Order No.	Selection and ordering data	Order No.
SIPART PS2 electropneumatic positioner, Ex d explosion protection, aluminum enclosure, without cable gland	6 DR 5 ■ ■ ■ 5 - 0 E ■ ■ ■ - ■ ■ A ■ ■	SIPART PS2 electropneumatic positioner, Ex d explosion protection, aluminum enclosure, without cable gland	6 DR 5 ■ ■ ■ 5 - 0 E ■ ■ ■ - ■ ■ A ■ ■
Version		Further designs	Order code
2-wire (4 to 20 mA)		Add "-Z" to Order No. and specify Order Code.	
• <u>Without</u> HART	▶ 0	Gauge made of steel,	R1A¹⁾
• <u>With</u> HART	▶ 1	Aluminium block, single-action G ¹ / ₄ , scaled in MPa, bar and psi	
2-, 3-, 4-wire (0/4 to 20 mA)		Gauge made of steel,	R2A¹⁾
• <u>With</u> HART	▶ 2	Aluminium block, double-action G ¹ / ₄ , scaled in MPa, bar and psi	
• <u>Without</u> HART	▶ 3	Gauge made of steel,	R1B⁴⁾
PROFIBUS PA connection	▶ 5	Aluminium block, single-action 1/4-18 NPT, scaled in MPa, bar and psi	
FOUNDATION Fieldbus connection	▶ 6	Gauge made of steel,	R2B¹⁾
		Aluminium block, double-action 1/4-18 NPT, scaled in MPa, bar and psi	
For actuator		Gauge made of stainless steel 316,	R1C¹⁾
Single-action	▶ 1	stainless steel block 316, single-action G ¹ / ₄ , scaled in MPa, bar and psi	
Double-action	▶ 2	Gauge made of stainless steel 316,	R2C⁴⁾
		stainless steel block 316, double-action G ¹ / ₄ , Skalierung MPa, bar, psi	
Connection thread electrical/pneumatic		Gauge made of stainless steel 316,	R1D¹⁾
M20 x 1.5 / G ¹ / ₄	▶	stainless steel block 316, single-action 1/4-18 NPT, scaled in MPa, bar and psi	
1/2-14 NPT / 1/4-18 NPT	▶	Gauge made of stainless steel 316,	R2D¹⁾
M20 x 1.5 / 1/4-18 NPT		stainless steel block 316, double-action 1/4-18 NPT, scaled in MPa, bar and psi	
1/2-14 NPT / G ¹ / ₄		Measuring point number (TAG No.)	Y17²⁾
M25x1.5 / G ¹ / ₄		Max. 8 characters for HART, max. 32 characters for PROFIBUS PA and FOUNDATION Fieldbus, specify in plain text: Y17:	
Limit monitor		measuring point description	Y15²⁾
Integrated		Max. 16 characters for HART, max. 32 characters for PROFIBUS PA and FOUNDATION Fieldbus, specify in plain text: Y15:	
Without	▶	Measuring point text	Y16²⁾
Alarm module; electronic (6DR4004-8A)		Max. 24 characters for HART, max. 32 characters for PROFIBUS PA and FOUNDATION Fieldbus, specify in plain text: Y16:	
Option modules		TAG plate made of stainless steel, 3-line	A20²⁾
Integrated		Text line 1: Plain text from Y17 Text line 2: Plain text from Y15 Text line 3: Plain text from Y16	
Without	▶	Preset bus address	Y25²⁾
Iy module for position feedback signal (4 ... 20 mA) (6DR4004-8J)		Specify in plain text: Y25: only for 6DR55.. and 6DR56..)	
Customer-specific design			
Without	▶		
Brief instructions			
German/English	▶		
French/Spanish/Italian			
Mounted pressure gauge block			
Without	▶		
Single-action G ¹ / ₄ , scaled in MPa and bar			
Double-action G ¹ / ₄ , scaled in MPa and bar			
Single-action 1/4-18 NPT, scaled in MPa and psi			
Double-action 1/4-18 NPT, scaled in MPa and psi			
Gauge version with order code R.. (see "Further designs")			

▶ Available ex stock (select combinations)

¹⁾ Available in April 2010

²⁾ On request

Electropneumatic positioners

SIPART PS2

Ordering data Accessories

Selection and ordering data	Order No.
Accessories	
NCS sensor for non-contacting detection of position (not for Ex d version), cable length 6 m (19.68 ft)	6 DR 4 0 0 4 - ■ NN ■ 0
Non explosion-proof	8
Explosion-protected, Ex ia/ib	6
For part-turn actuators, without mounting console	1
For linear actuators up to 14 mm (0.55 inch), without mounting bracket	2
For linear actuators > 14 mm (0.55 inch), up to 130 mm (5.12 inch), mounting kit same as for SIPART PS2 (sep. ordering item). The EMC filter module is additionally required for the controller unit (sep. order item, see below)	3

Selection and ordering Data	Order No.
Accessories	
Alarm unit for 3 alarm outputs and 1 binary input (functionality: 2 limit monitors, 1 fault alarm, 1 binary input)	
• Not explosion-proof	▶ 6DR4004-8A
• With explosion protection CENELEC/ATEX	▶ 6DR4004-6A
• With explosion protection FM/CSA ¹⁾	▶ 6DR4004-7A
SIA module (slot-type initiator alarm unit, not for Ex d version)	
• Not explosion-proof	▶ 6DR4004-8G
• With CENELEC/ATEX and FM/CSA explosion protection ¹⁾	▶ 6DR4004-6G
Limit value contact module (with mechanical ground contacts, not for Ex d version)	
• Not explosion-proof	▶ 6DR4004-8K
• With explosion protection	▶ 6DR4004-6K
ly module for position feedback signal (4 to 20 mA)	
• Not explosion-proof	▶ 6DR4004-8J
• With explosion protection CENELEC/ATEX	▶ 6DR4004-6J
• With explosion protection FM/CSA ¹⁾	▶ 6DR4004-7J
HART modem for connecting to PC or laptop	
• with RS232 interface	▶ 7MF4997-1DA D)
• with USB interface	▶ 7MF4997-1DB D)
EMC filter module for connection of external position sensor (10 kΩ) or NCS sensor (not for Ex d version)	C73451-A430-D23
Gauge made of steel. Aluminium block, single-action G ¹ / ₄ , scaled in MPa, bar and psi	6DR4004-1P ²⁾
Gauge made of steel. Aluminium block, double-action G ¹ / ₄ , scaled in MPa, bar and psi	6DR4004-2P ²⁾
Gauge made of steel. Aluminium block, single-action 1/4-18 NPT, scaled in MPa, bar and psi	6DR4004-1PN ²⁾
Gauge made of steel. Aluminium block, double-action 1/4-18 NPT, scaled in MPa, bar and psi	6DR4004-2PN ²⁾
Gauge made of stainless steel 316. stainlesssteel block, single-action G ¹ / ₄ NPT, scaled in MPa, bar and psi	6DR4004-1Q ²⁾

Gauge made of stainless steel 316. stainless steel block, double-action G ¹ / ₄ , scaled in MPa, bar and psi	6DR4004-2Q ²⁾
Gauge made of stainless steel 316. stainless steel block, single-action 1/4-18 NPT, scaled in MPa, bar and psi	6DR4004-1QN ²⁾
Gauge made of stainless steel 316. stainless steel block, double-action 1/4-18 NPT, scaled in MPa, bar and psi	6DR4004-2QN ²⁾
Two terminal blocks made of stainless steel 316. For replacement of the aluminum terminal blocks in the 6DR4004-8V, -8VK and -8VL mounting kits for NAMUR linear actuators.	6DR4004-8N ²⁾
Roll and disk made of stainless steel 316 For replacement of the Teflon roll and aluminum disk in the 6DR4004-8, -8VK and -8VL mounting kits for NAMUR linear actuators	6DR4004-9N ²⁾
Pneumatic terminal strips made of stainless steel 316 For replacement of the pneumatic terminal strip made of aluminum for the SIPART PS2 with Macrolon enclosure	
single-action with G ¹ / ₄	6DR4004-1R
double-action with G ¹ / ₄	6DR4004-2R
single-action with 1/4-18 NPT	6DR4004-1RN
double-action with 1/4-18 NPT	6DR4004-2RN
Mounting kit for NAMUR part-turn actuators	
(VDI/VDE 3845, with plastic coupling wheel, without mounting console)	▶ 6DR4004-8D
(VDI/VDE 3845, with stainless steel coupling, without mounting console)	▶ TGX:16300-1556 C)
The following mounting consoles can be used with the NAMUR part-turn actuator mounting kit 6DR4004-8D. Size W x L x H (H = height of shaft butt)	
• 30 x 80 x 20 mm	▶ TGX:16152-105 C)
• 30 x 80 x 30 mm	▶ TGX:16300-147 C)
• 30 x 130 x 30 mm	▶ TGX:16300-149 C)
• 30 x 130 x 50 mm	▶ TGX:16300-151 C)
Mounting kit for other part-turn actuators	
The following mounting consoles can be used together with the NAMUR part-turn actuator mounting kit 6DR4004-8D#.	
• SPX (DEZURIK) Power Rac, sizes R1, R1A, R2 and R2A	▶ TGX:16152-328 C)
• Masoneilan Camflex II	▶ TGX:16152-350 C)
• Fisher 1051/1052/1061, sizes 30, 40, 60 to 70	▶ TGX:16152-364 C)
• Fisher 1051/1052, size 33	▶ TGX:16152-348 C)
Mounting kit for NAMUR linear actuators	
NAMUR linear actuator mounting kit with short lever arm (2 to 35 mm)	▶ 6DR4004-8V
• Lever arm for travels from 35 mm to 130 mm (1.38 inch to 5.12 inch)	▶ 6DR4004-8L
• Reduced mounting kit for linear actuator (like 6DR4004-8V but without fixing angle and U-bolt), with short lever with up to 35 mm (1.38 inch) travel	▶ 6DR4004-8VK
• Reduced mounting kit for linear actuator (like 6DR4004-8V but without fixing angle and U-bolt), with short lever with up to 35 mm (1.38 inch) travel	▶ 6DR4004-8VL

Electropneumatic positioners

SIPART PS2

Ordering data

Accessories

Mounting kit for other linear actuators

- Retrofitting kit for Moore series 72 and 750 valve positioners ▶ **TGX:16152-117**
C)
- Fisher type 657/667, size 30 to 80 ▶ **TGX:16152-110**
C)
- Samson actuator type 3277 ▶ **6DR4004-8S**
(yoke dimension (H5) = 101 mm³)
(integrated connection without tube),
not for Ex d

Pipe mounting

Mounting bracket for pipe mounting of the SIPART PS2 positioner (e.g. when using the NCS sensor) ▶ **TGX:16152-336**
C)

Additional actuator components can be found at the following Internet address:
www.siemens.de/sipartps2

Customer-spec. mounting kits avail. on request.

Manometer made from palstic, including pressure gauge

- For single-action SIPART PS2 positioner (2 manometers, scaled in MPa and bar) ▶ **6DR4004-1M**
- For double-action SIPART PS2 positioner (3 manometers, scaled in MPa and bar) ▶ **6DR4004-2M**
- For single-action SIPART PS2 positioner with NPT thread (2 manometers, scaled in MPa and psi) ▶ **6DR4004-1MN**
- For double-action SIPART PS2 positioner with NPT thread (3 manometers, scaled in MPa and psi) ▶ **6DR4004-2MN**

Connection block, for safety solenoid valve with extended mounting flange to NAMUR

- For mounting to IEC 534-6 ▶ **6DR4004-1B**
- For SAMSON actuator (integrated mounting) see above ▶ **6DR4004-1C⁴⁾**

External position detection system (with explosion protection to CENELEC/ATEX, Ex ia, ib) for separate mounting of position sensor and controller (not for Ex d version), comprising SIPART PS2 Makrolon casing with integral potentiometer and sliding clutch (without electronics and valve block). The EMC filter module is additionally required for the controller unit. (separate ordering item, see below). **C73451-A430-D78**

Documentation (see notes below)

Instruction Manual for SIPART PS2

- German/English **A5E00074600**
- French/Italian/Spanish **A5E00074601**

Instruction Manual for SIPART PS2 PROFIBUS PA

- German/English **A5E00120716**
- French/Italian/Spanish **A5E00120717**

Instruction Manual for NCS Sensor

- German/English/French/Spanish/Italian **A5E00097485**

SIPART PS2 device documentation

- CD-ROM with complete documentation for all device versions **A5E00214567**

Device manual for SIPART PS2 (not PA and FF)

- German **A5E00074630**
- English **A5E00074631**

Manual for SIPART PS2 PROFIBUS PA

- German **A5E00127924**
- English **A5E00127926**

SITRANS I200 output isolator HART

(see "SITRANS I supply units and isolation amplifiers") with

- 24 V DC power supply ▶ **7NG4131-0AA00**

▶ Available ex stock (select combinations).

C) Subject to export regulations AL: N, ECCN: EAR99.

- 1) U.S. certification by FM insitute
- 2) Available as from January 2010
- 3) With a yoke dimension H5 = 95 mm, only the SIPART PS2 in an aluminum enclosure can be used (6DR5..1-...)
- 4) Only together with 6DR4004-8S und 6DR4004-1M

Note:

All the above mentioned manuals are included on CD-ROM and can be downloaded from www.siemens.de/sipartps2.

Following manuals are available in addition as downloads from the Internet or are included on CD-ROM:

- Instruction Manual Compact SIPART PS2 FF, Electropneumatic Positioner (6DR56..) with Foundation Fieldbus - German/English: A5E00214570
- Instruction Manual SIPART PS2 FF, Electropneumatic Positioner (6DR56..) with FOUNDATION Fieldbus - German: A5E00214568 - English: A5E00214569

Scope of delivery for positioner

- 1 SIPART PS2 positioner as ordered
- 1 CD-ROM with the complete documentation for all versions and accessories
- Manual "SIPART PS2 - Configuration At a Glance"

More Information

Special versions

On request

Dimensional drawings

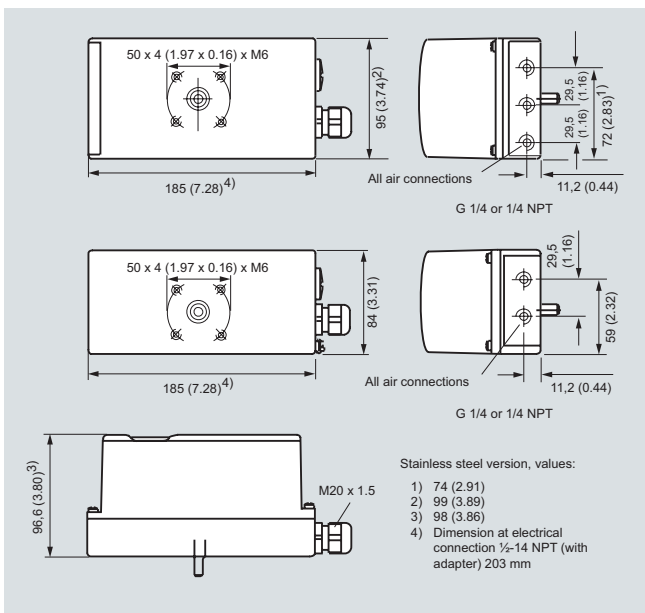

Makrolon and stainless steel enclosure (top), aluminum enclosure (center), Makrolon and aluminum enclosure (bottom), dimensions in mm (inch)

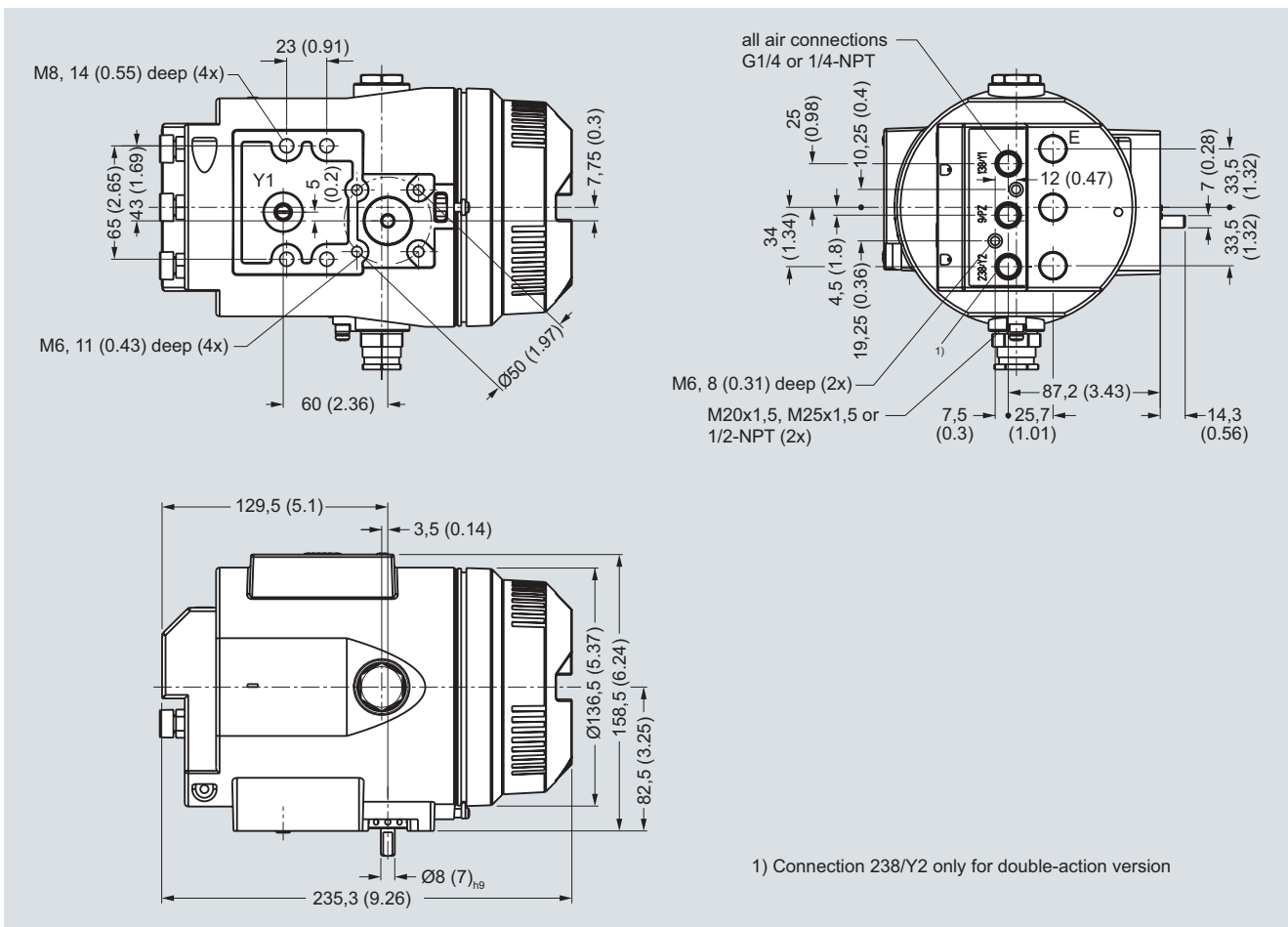

Flameproof enclosure left, dimensions in mm (inch)

Electropneumatic positioners SIPART PS2

Schematics

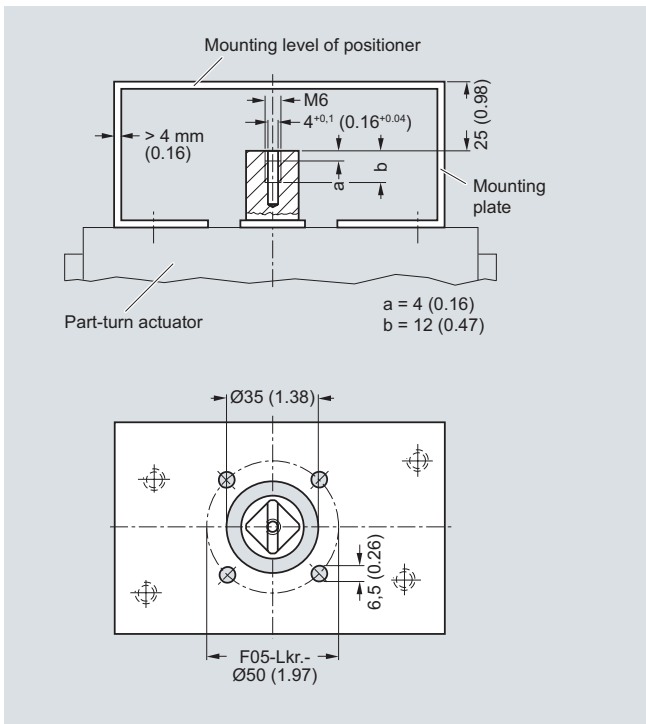

Mounting onto part-turn actuators; mounting consoles (scope of delivery of actuator manufacturer), extract from VDI/VDE 3845, dimensions in mm (inch)

6

Schematics

Electric connection of 2-wire devices (6DR50.. and 6DR51..)

Devices of types 6DR50.. and 6DR51.. are operated in a 2-wire system.

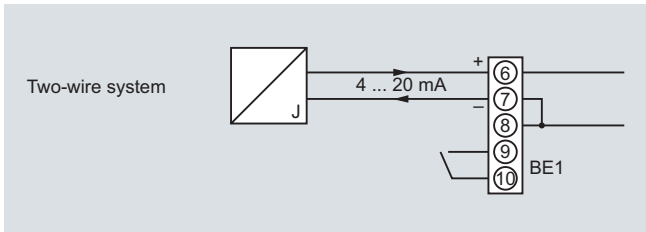

SIPART PS2 electropneumatic positioner, input circuit for 6DR50.. and 6DR51..

Electric connection of PROFIBUS PA device (6DR55..) and Foundation Fieldbus device (6DR56..)

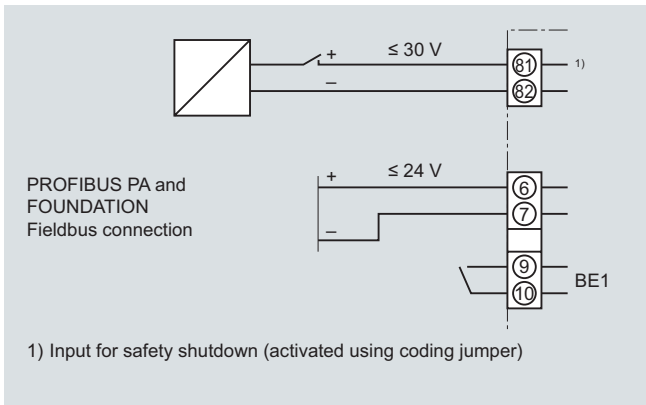

SIPART PS2 PA and SIPART PS2 FF electropneumatic positioner, input circuit for 6DR55.. and 6DR56..

Electric connection of 2-, 3- and 4-wire device (6DR52.. and 6DR53..)

Devices of types 6DR52.. and 6DR53.. can be operated in a 2-, 3- and 4-wire system.

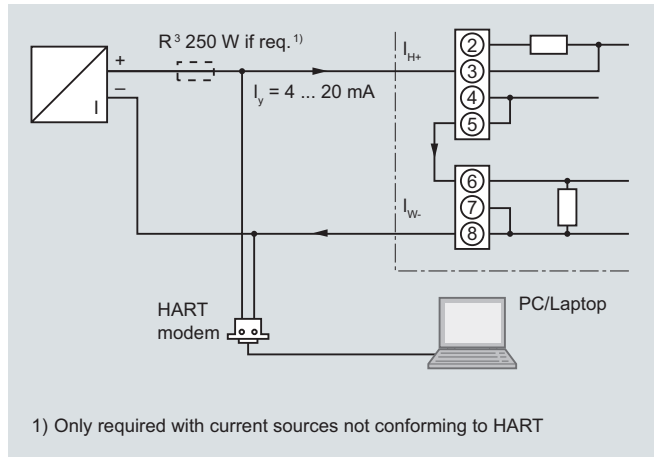

SIPART PS2 electropneumatic positioner, example of connection for communication through HART for 6DR52..

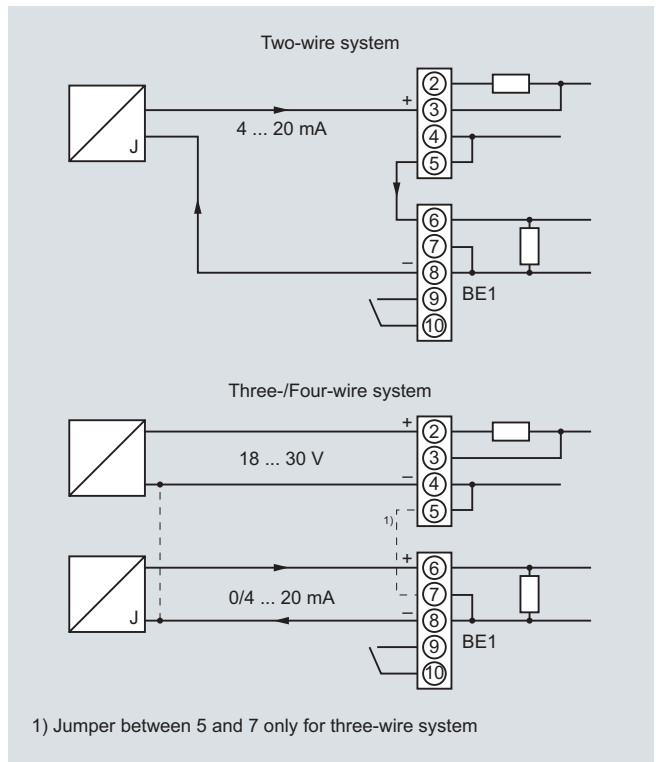

SIPART PS2 electropneumatic positioner, input circuits for 6DR52.. and 6DR53..

Mounting kit for NAMUR linear actuators

- 1 mounting bracket
- 2 mounting prisms
- 1 U-bracket
- 1 lever arm with adjustable pick-up roll
- 2 U-bolts
- Various screws and lock washers

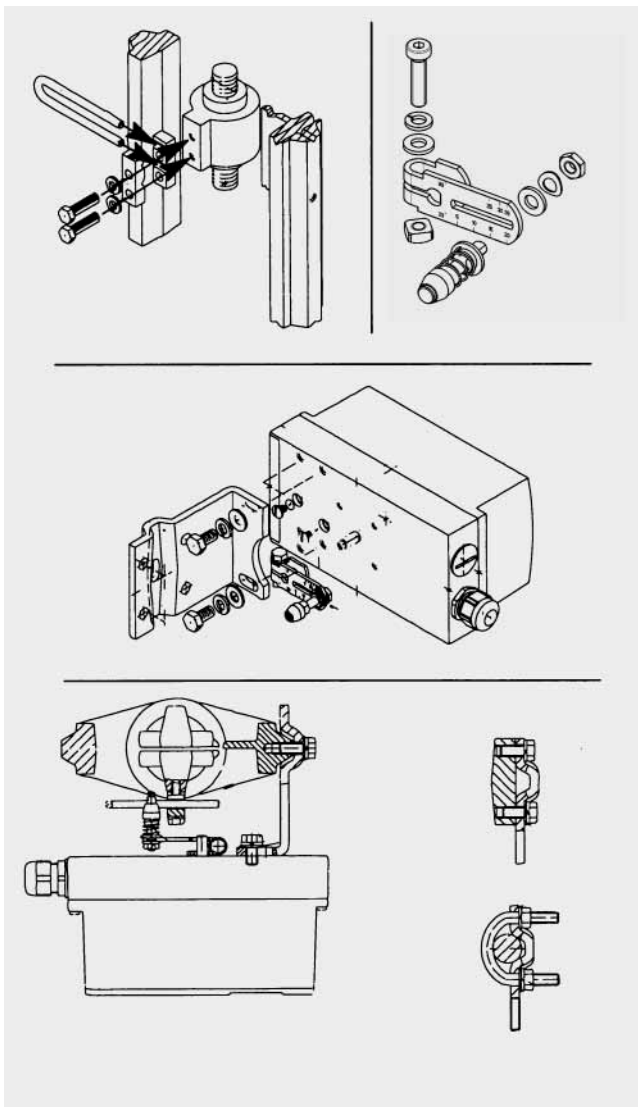

Mounting of SIPART PS2 on linear actuators

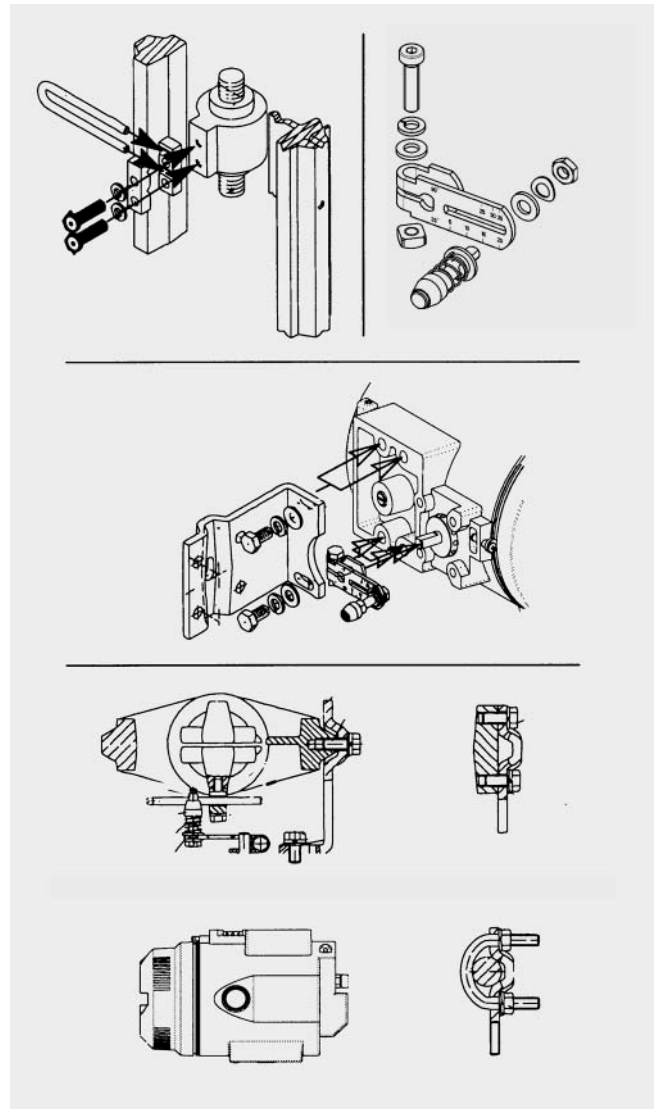

Mounting of SIPART PS2 Ex d on linear actuators

Electropneumatic positioners

SIPART PS2

Mounting kit

Mounting kit for NAMUR part-turn actuators

- 1 coupling wheel
- 1 driver pin
- 8 scales
- 1 pointer
- Various screws and lock washers

Caution: The mounting consoles and the screws for mounting onto the part-turn actuator are not included in the scope of delivery and must be provided by the customer (see "Technical specifications")

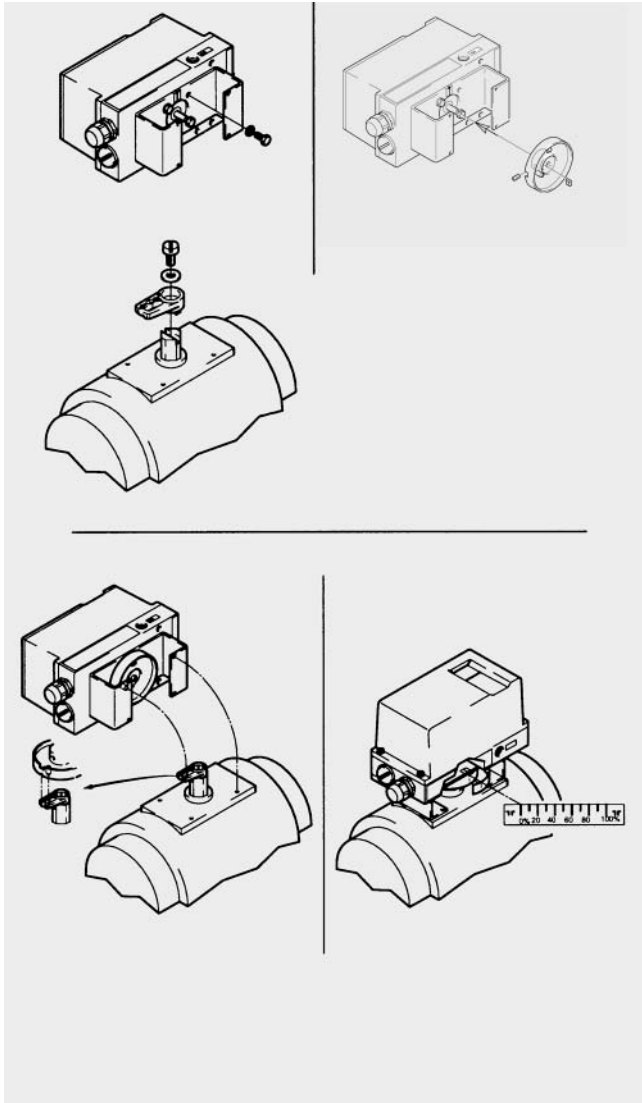

Mounting of SIPART PS2 on part-turn actuators

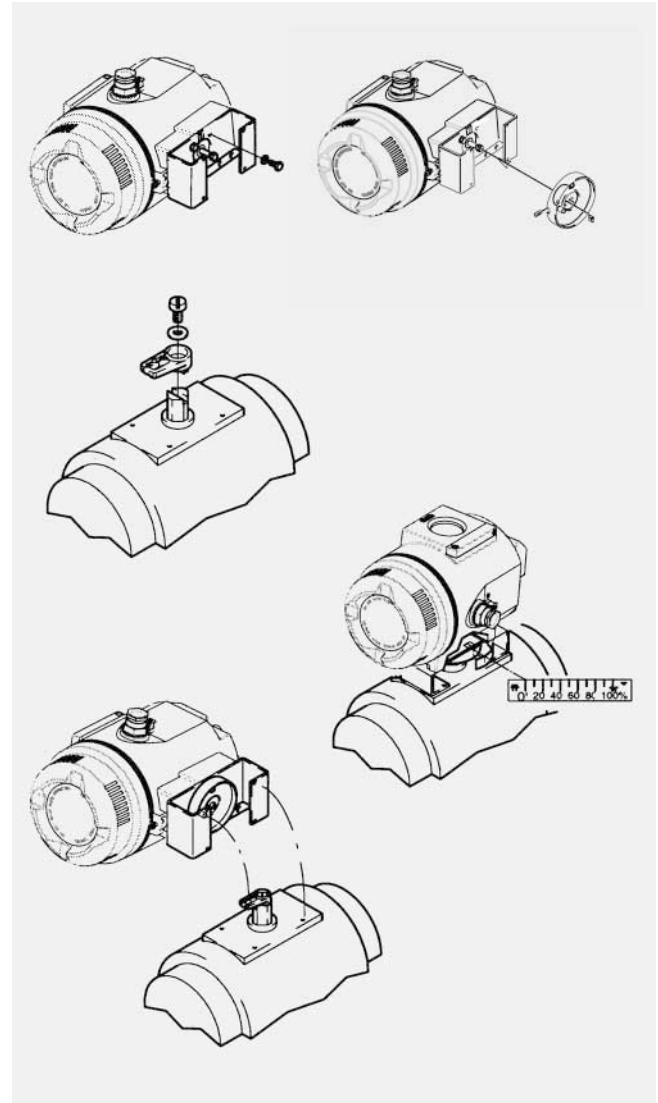

Mounting of SIPART PS2 Ex d on part-turn actuators