

SRD998 Intelligent Positioner with HART Communication



The intelligent positioner SRD998 is designed to operate pneumatic valve actuators and can be operated from control systems (e.g. the Foxboro I/A Series System and Foxboro Evo™), controllers or PC-based configuration and operation tools such as the FDT/DTMs VALcare™. The positioner is available with HART 7 communication protocol. The extra large multi-lingual full text graphical-LCD, in conjunction with the rotary selector, allows a comfortable and easy local configuration and operation. For installations in contact with explosive atmospheres, certificates are available.

MAIN FEATURES

Intelligent

- Auto-start with self-calibration
- Self diagnostics, status- and diagnostic messages
- Easy local operation with the rotary selector
- Extra large multi-lingual full text graphical LCD
- VALcare™ DTM with comprehensive data for fast configuration
- With HART 7 communication
- Stroke 8 to 260 mm (0.3 to 10.2 in) with standard lever; larger stroke with special lever
- Angle range up to 95 ° angle
- Mounting onto any linear or rotary actuator
- Supply air pressure up to 6 bar (90 psig)
- Single or double acting
- Protection class IP 66 and NEMA 4X
- Explosion protection: Intrinsic Safety according to ATEX / IECEx, INMETRO, NEPSI, ...



Life Is On

Foxboro
by Schneider Electric

Labels

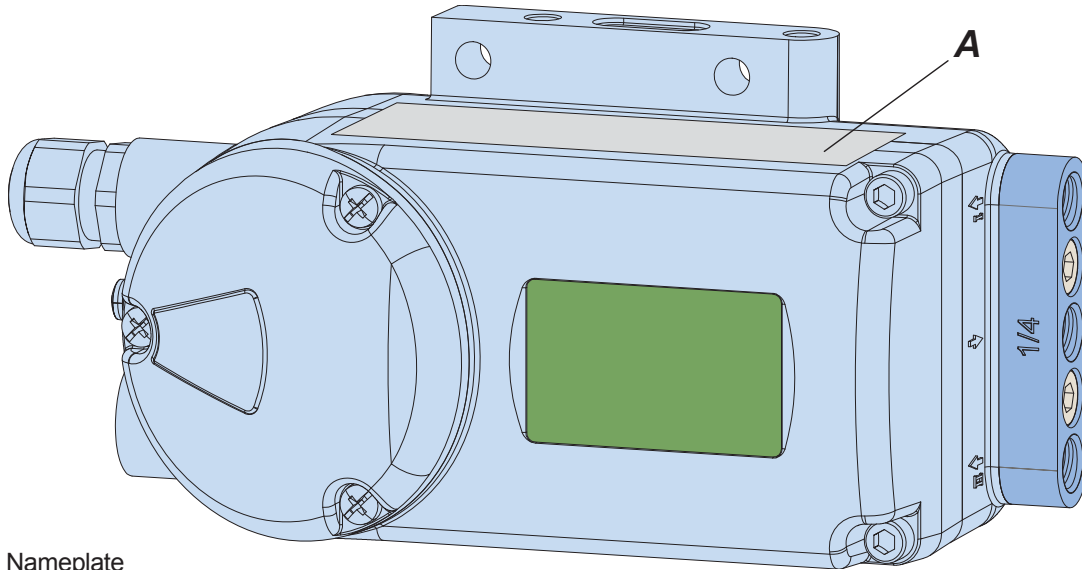

A Nameplate

Nameplate A (Example)
Without Ex protection

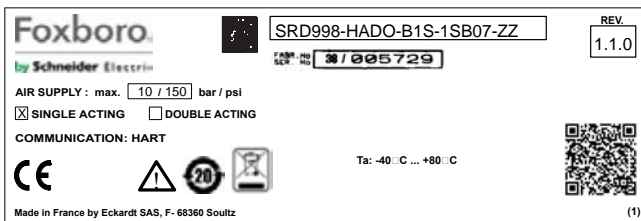

Nameplate A (Example)
With Ex protection acc. to ATEX

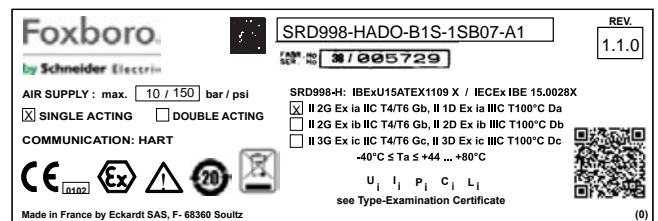

- SRD [Device specification, Model Code]
- SER.No [Serial number]
- ECEP [Number for special engineered version]

Measurement point label (Example)
Directly fixed or attached

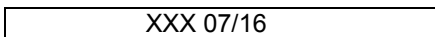

Additional manufacturing data are stored in the software and are read via communication interface.

TABLE OF CONTENTS

CHAP: CONTENT	PAGE	CHAP: CONTENT	PAGE
LABELS	2	8 START-UP	19
1 METHOD OF OPERATION	4	8.1 Operation	19
1.1 General.....	4	8.2 Configuration.....	20
1.2 Block diagram.....	4	8.3 Overview: Menu structure.....	21
1.3 Operation.....	4	8.4 Description of menus	23
2 OPERATING MODES	5	9 DECOMMISSIONING	36
3 FUNCTIONAL DESIGNATIONS	6	10 MAINTENANCE	37
3.1 Pneumatic accessories	7	10.1 Supply filter replacement.....	37
4 MOUNTING TO ACTUATORS	8	10.2 Separate upper from lower housing... 37	
4.1 Linear, NAMUR Mounting, left hand	8	10.3 Removal of the electronics unit.....	37
4.2 Linear, NAMUR Mounting, right hand.....	10	10.4 Removal of the pneumatic assembly....	37
4.4 Rotary actuators	14	11 TROUBLE-SHOOTING GUIDE	38
5 PNEUMATIC CONNECTIONS	16	12 SAFETY REQUIREMENTS	43
6 ELECTRICAL CONNECTION	17	13 SYSTEM CONFIGURATION	43
		14 DIMENSIONS	46

Installation and start-up of instrument to be carried out only by qualified personnel, familiar with installation and start-up procedures and operation of this product!

Accident prevention

The connected instrument contains mechanical moving parts, e.g. feedback lever, which could cause injuries. The operators have to be instructed accordingly.

Electrical safety

This instrument satisfies the conditions for safety class III, overvoltage category I according to EN 61010-1 or IEC1010-1.

Any work on electrical parts must be done by qualified personnel if any supply is connected to the instrument. The instrument must be used for its designated purpose

and connected in accordance with its connection diagram. Locally applicable installation regulations for electrical equipment must be observed, e.g. in the Federal Republic of Germany DIN VDE 0100 resp. DIN VDE 0800.

The instrument must be operated with safety extra low voltage SELV or SELV-E.

Safety precautions taken in the instrument may be rendered ineffectual if the instrument is not operated in accordance with the Master Instructions.

Limitation of power supplies for fire protection must be observed due to EN 61010-1, appendix F or IEC 1010-1.

1 METHOD OF OPERATION

1.1 General

The intelligent positioner SRD998 **1** and the pneumatic actuator **2** form a control loop with the setpoint value w (from master controller or control system), the output pressure y and the position x of the actuator on valve **3**.

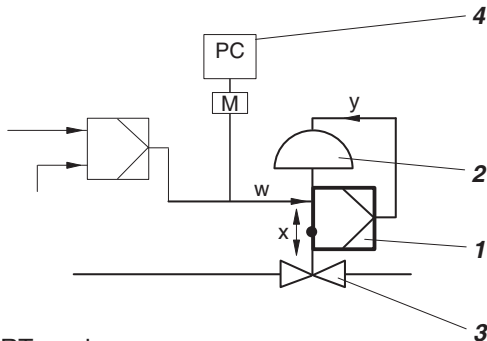

Fig.: HART version

For the supply air, we recommend the FRS02 / 03 / 923 filter regulator.

The positioner can be attached to both linear and rotary actuators.

Actuators with spring force are controlled by a single acting positioner. Actuators without spring force are controlled by a double acting positioner.

HART version:

The positioner can be operated locally by means of Rotary Selector and LCD, Hand Held Terminal, remotely via PC-based configuration like FDT / DTM or a corresponding control system, e.g. I/A Series System.

1.2 Block diagram

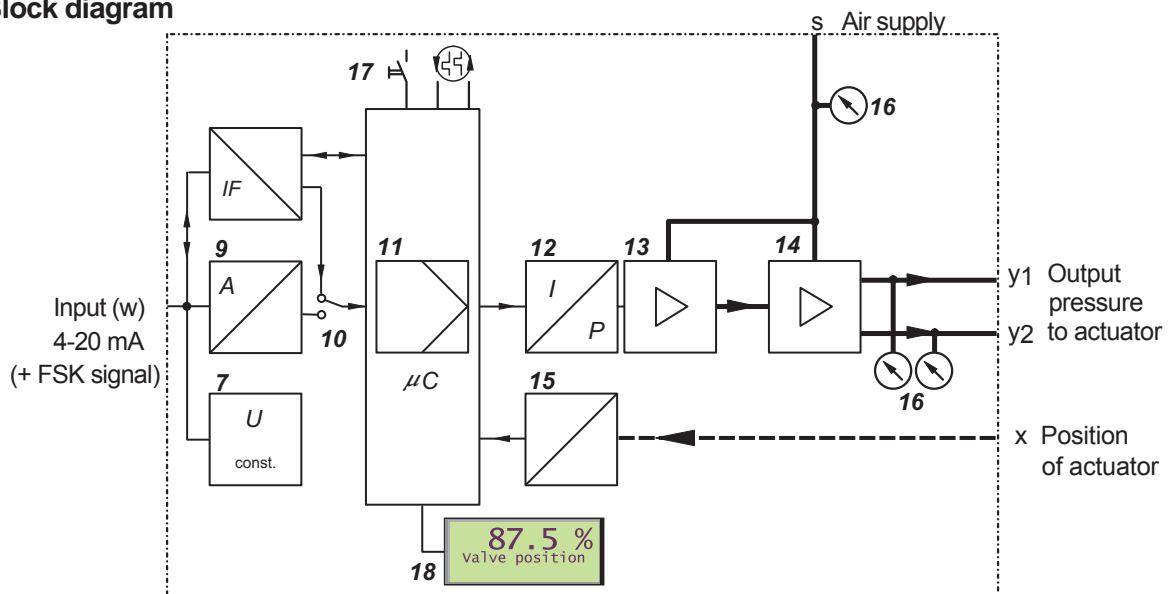

1.3 Operation

With the intelligent positioner with input signal 4-20 mA and superimposed HART signal, the supply takes place via the power signal adjacent to the input.

By means of voltage converter **7**, derivation of the internal supply of the electronics takes place. The current value is measured, in A/D transformer **9** converted, and directed via switch **10** to digital controller **11**.

The output of controller **11** drives the electro-pneumatic converter (IP-module) **12**, controlling a pre-amplifier **13**, the single acting (or double acting) pneumatic power amplifier **14**. The output of the amplifier **14** is the output pressure y to the actuator.

The pneumatic amplifiers are supplied with supply air s 1.4 to 6 bar (20 to 90 psig).

The position x of the actuator is sent to the control unit **11** by the position sensor (conductive plastic potentiometer) **15**.

Optional gauges **16** enable additional diagnostic indications.

Adjusting, start-up of the positioner as well as the demand for internal information can be made using the Rotary Selector **17**, with indication given by LCD **18**.

2 OPERATING MODES

Operation of the positioner is divided into individual 'operating modes'. Operating modes may change depending on, for example, key commands or internal calculations. The different operating modes are described in abbreviated form below.

INITIALIZE:

Upon power-up, several self-tests are conducted. Individual steps in the self-test process are indicated by the LCD.

If no error occurs the device moves to OUT OF SERVICE, if it is still in a delivery condition; AUTOSTART has to be performed. If AUTOSTART was done already, the device will go to IN OPERATION.

If faults are detected, the code of the faulty self-test will remain. If error reoccurs after reset, please check trouble-shooting guide or contact customer service.

DEVICE FAULT:

In the event that the LCD shows a message, a device fault is signaled. These faults are detected during cyclical self-test.

The device can no longer be operated. This could be caused by a jammed menu key, defective program memory, etc. (see chapter "Trouble shooting").

If a device error occurs repeatedly, please contact customer service.

IN OPERATION:

After performing an AUTOSTART, the device moves to IN OPERATION and will always, even after restarting or re-setting, move back to the safety position (de-energized valve position) or FAILSAFE. If setpoint values are fed via communication, the SRD will go to IN OPERATION.

OUT OF SERVICE:

The SRD in delivered condition is configured in such a way that it will remain OUT OF SERVICE after power-up until moving to IN OPERATION via the manually initiated function AUTOSTART.

In the device state OUT OF SERVICE, the menu entering mode remains active at all times. If a device has been IN OPERATION already and is removed from an actuator and mounted to another, it is recommended to take the device out of operation via "Reset to Factory" (Menu 10.1) prior to disconnecting the device from the first actuator.

This enables the next actuator to be started in the delivered condition (see chapter 8).

CALIBRATE:

During an AUTOSTART function the device is in condition CALIBRATION. The actuator is moved up- and downward several times, and the device could be busy for a few minutes.

Subsequently, the device moves to IN OPERATION.

MESSAGES:

The SRD continuously supervises important device functions. In the case that limit values are exceeded or operational problems occur, messages are signaled via the LCD.

The message with the highest priority will be indicated first. With rotary selector other messages can be called up. Further references may be found in chapter "Trouble shooting".

LCD description and possible operator interventions are described in chapter: START-UP.

3 FUNCTIONAL DESIGNATIONS

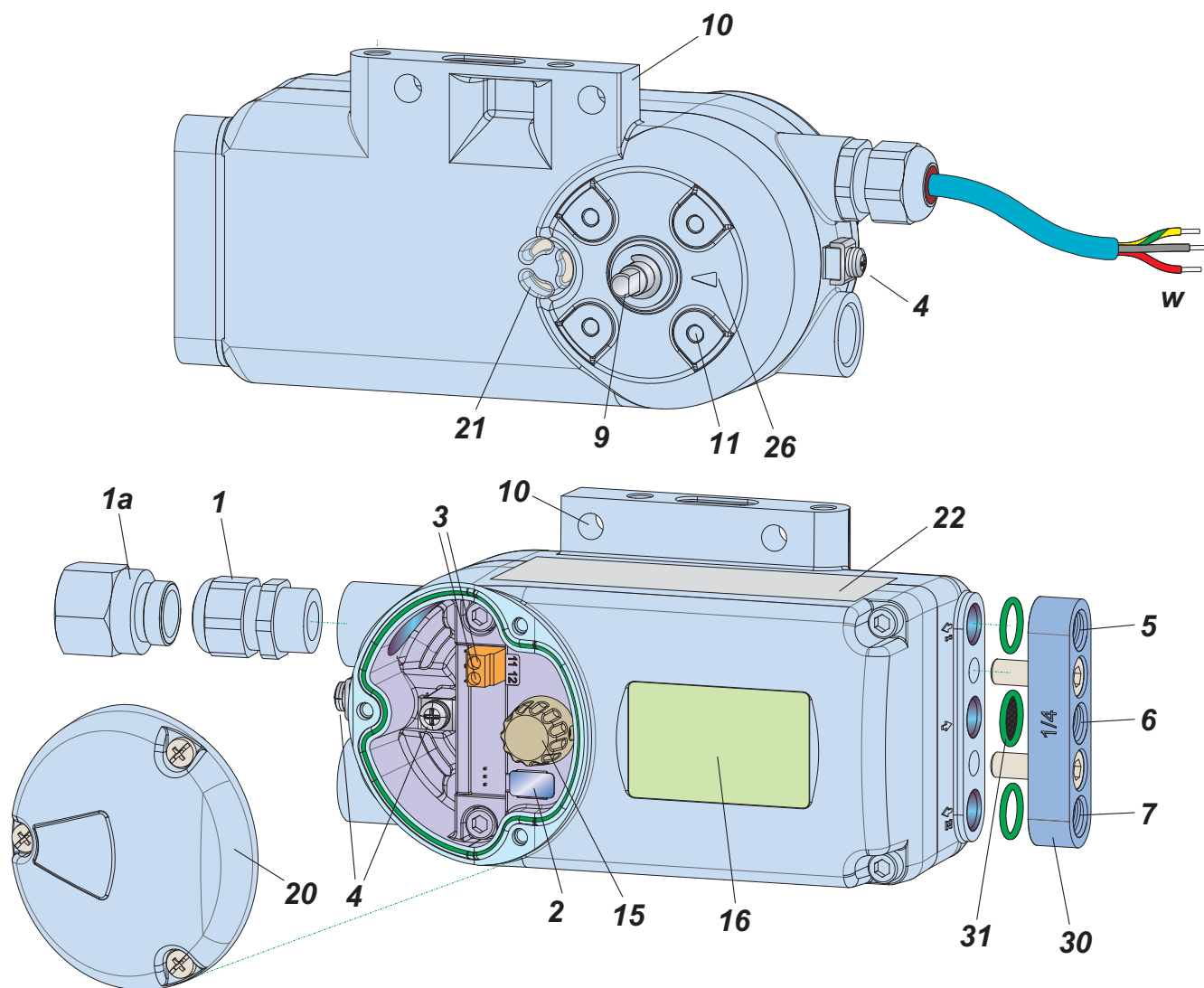

- | | |
|--|--|
| 1 Cable gland * | 15 Turn Rotary Selector for Menu selection and press to confirm |
| 1a Adapter, eg. 1/2"-14 NPT | 16 LCD with true text in different languages |
| 3 Screw terminals (11 / 12) for input (w) | 20 Cover for electrical connection compartment |
| 4 Ground connection (inner and outer) | 21 Air vent, dust and water protected |
| 5 Output I (y1) | 22 Data label |
| 6 Air supply (s) | 26 Arrow is perpendicular to shaft 9 at angle 0 degree |
| 7 Output II (y2) | 29 Plug for service connector under the lid (factory only) |
| 9 Feedback shaft | 30 Connecting manifold, G 1/4 or 1/4 NPT
Not required when mounting a gauge manifold, or a direct mounted volume booster |
| 10 Connection manifold for attachment to stroke actuators | 31 O-ring with filter, for air supply connection |
| 11 Connection base for attachment to rotary actuators | |

* Device is shipped with a closing sticker.
Remove sticker and mount a cable gland.

3.1 Accessories, for all basic devices

When mounting check the proper seating of the O-rings and bolt on the accessories with the two M8 bolts. Tightening torque is 20 Nm.

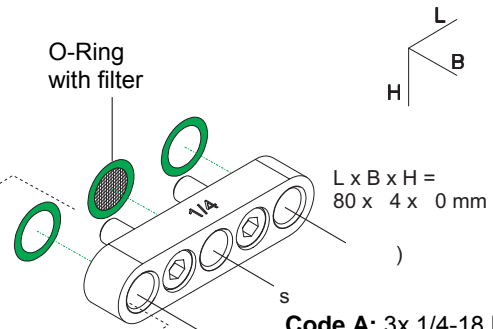
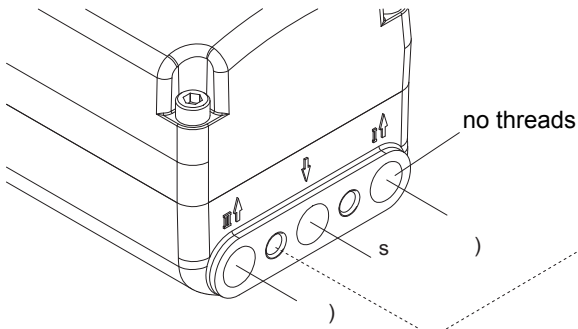

Code A: 3x 1/4-18 NPT
Code B: 3x G 1/4
 Connection manifold

Sticker closes the unused output at single acting

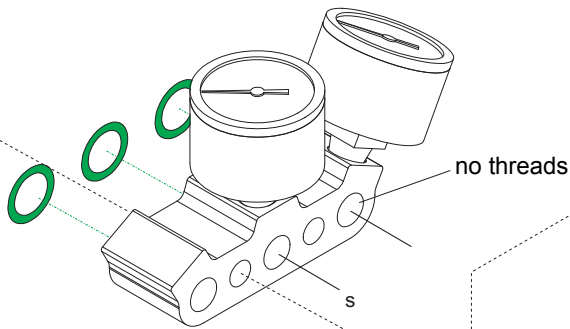

Code 1 or 2, single
 Connection manifold for single acting positioner with pressure gauges for supply air s and output y

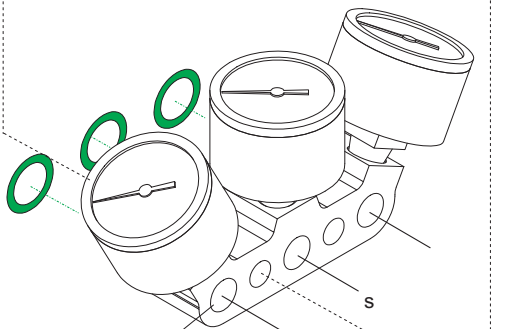

Code 3 or 4, double
 Connection manifold for double acting positioner with pressure gauges for supply air s, outputs y1 and y2

Boosters for remote mounting:
 (see extra PSS)

VBS100

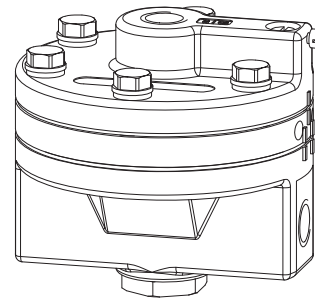

VBS300

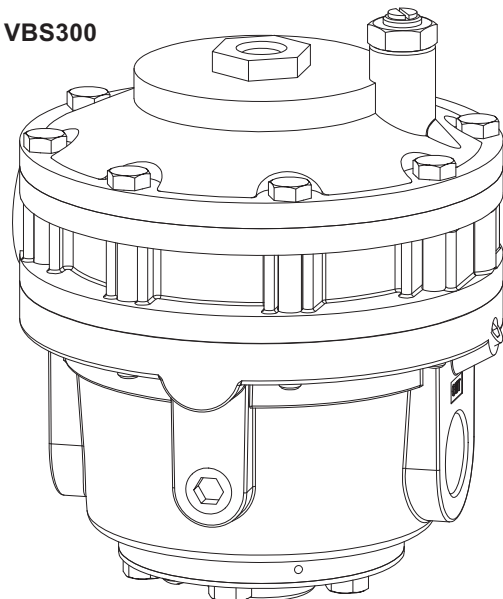

4 MOUNTING TO ACTUATORS

4.1 NAMUR Mounting linear actuator, left hand

Applicable to actuators with cast yoke or pillar yoke acc. to NAMUR (DIN IEC 534-6).

Mounting the positioner with pneumatic connections on the left side and electrical connections on the lower right side.

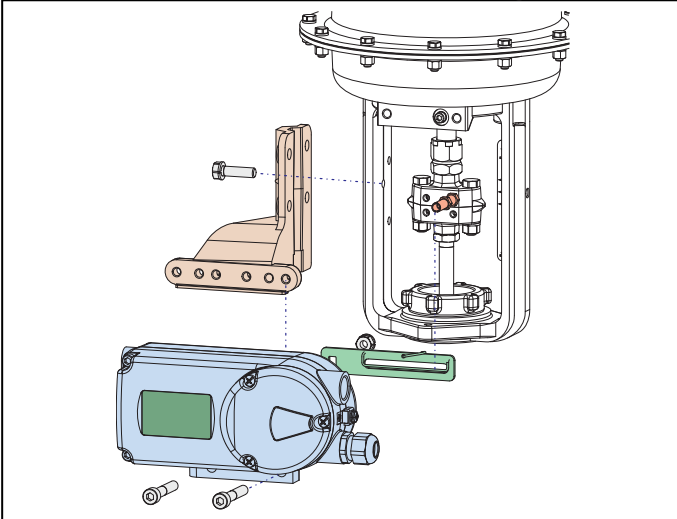

Attachment of the positioner to the actuator is made to the left using the mounting bracket and feedback lever for a NAMUR mount. Use:

attachment kit EBZG -H for a cast yoke, or
attachment kit EBZG -K for a pillar yoke.

The side outputs I (or I and II) are used.

Pneumatic connections: Do not use Teflon tape for sealant. The fine fibres could disturb the function of the SRD. Use only Loctite® #243 for sealant ¹⁾.

Screw-type glands for electrical connections are positioned on the side. Device is shipped with a closing sticker; remove sticker and mount a cable gland or, if unused, a closing plug.

4.1.1 Preparation of the positioner

Rotate the shaft stub of shaft **9** so that the flat on the shaft stub is perpendicular to the arrow **26** on the housing at mid travel range. Fasten the feedback lever **A** to the shaft by means of spring washer and nut M8.

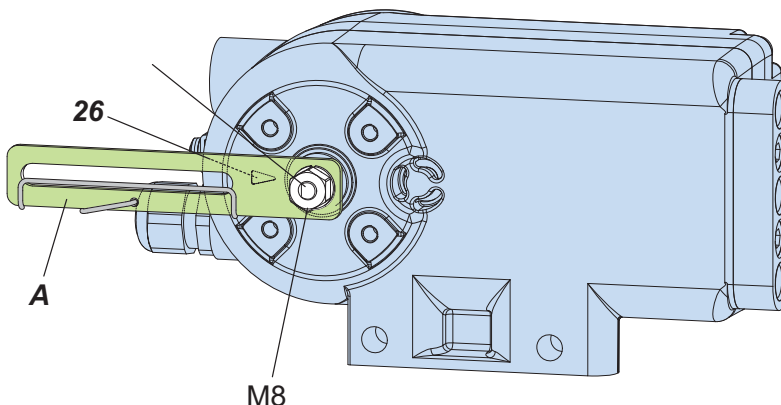

1) Apply only to male thread

4.1.2 Preparation of the actuator

Screw the carrier bolt to the stem connector (see page 12) and lock it by means of a counter nut.

A carrier bolt with an adjustable length is used to be able to screw on various coupling pieces.

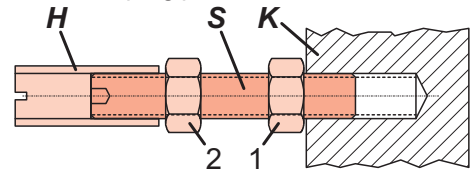

It consists of a stud S (size M6), which is screwed into the coupling piece K (with 3 mm Allen key) and locked with a lock nut 1. The threaded sleeve H is screwed onto it and locked with a lock nut 2. Make sure that the bolt is adjusted to the right length!

Fasten the mounting bracket to the left side of the yoke.

For a cast yoke use a screw M8 x 30,
for a pillar yoke use two U-bolts and four nuts.

4.1.3 Mounting of the positioner

Fasten the positioner to the mounting bracket using two spring washers and two screws M8 x 80.

Note, the carrier bolt **B** is in the slot of the feedback lever **A** and the compensating spring F touches the carrier bolt.

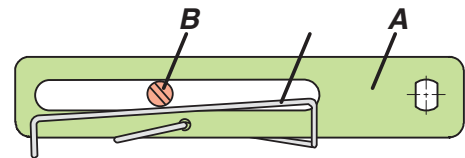

Fig.: Feedback lever

For optimum utilization of the positioner operating range, it is recommended that the arrangement is adjusted according to the following procedure before fixing. At an actuator position in the middle of travel range, the feedback lever position should be perpendicular to the actuator stem and the angle range should be between $\pm 10^\circ$ and $\pm 45^\circ$.

Fasten the positioner to the mounting bracket so that a suitable angle range is selected.

It is recommended that the pneumatic and electrical connections are made after adjusting the position.

4.1.4 NAMUR Mounting Dimensions – left hand –

LCD orientation can be changed by means of local operation from "normal" to „upside down“, to ensure a correct orientation of the display.

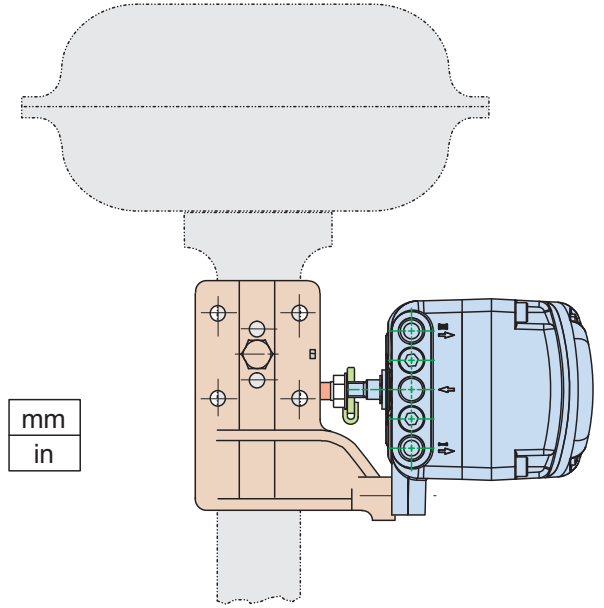
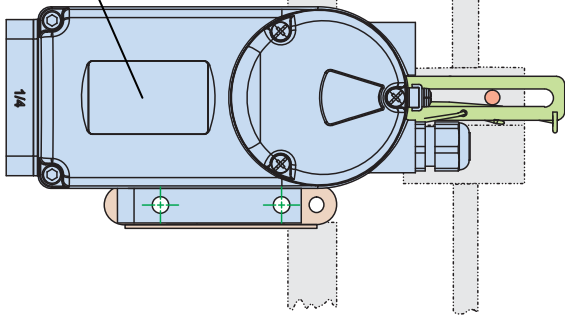

mm
in

Attachment to casting yoke (with attachment kit Code EBZG-H)

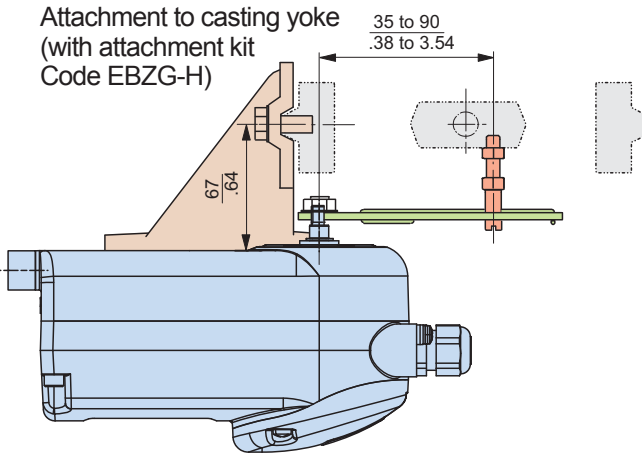

Mounting bracket

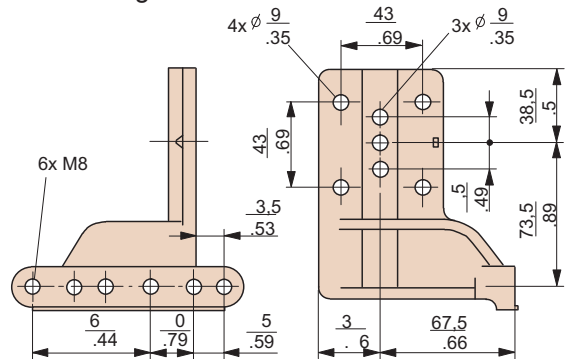

Attachment to pillar yoke (with attachment kit Code EBZG-K)

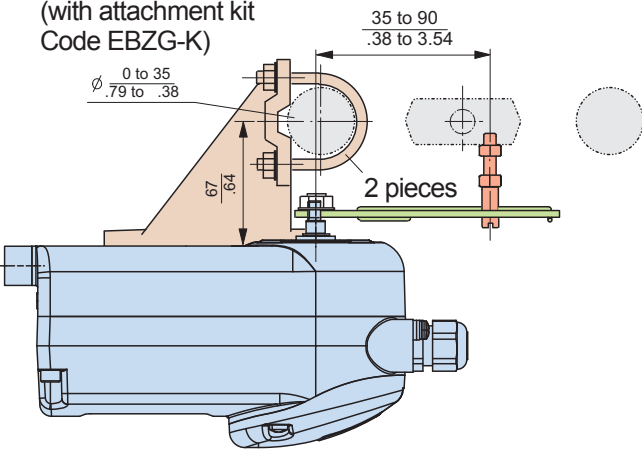

Feedback lever Code EBZG-A for 8 to 70 mm travel

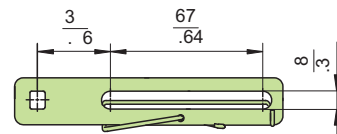

Carrier bolt for connection to valve stem

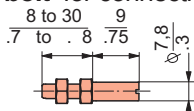

Feedback lever Code EBZG-B for 60 to 120 mm travel

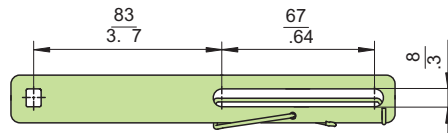

4.2 NAMUR Mounting linear actuator, right hand

Right-hand mounting is done if for instance left-hand mounting is not possible for structural reasons.

Applicable to actuators with cast yoke or pillar yoke acc. to NAMUR (DIN IEC 534-6).

Mounting the positioner with pneumatic connections on the right side and electrical connections on the left side.

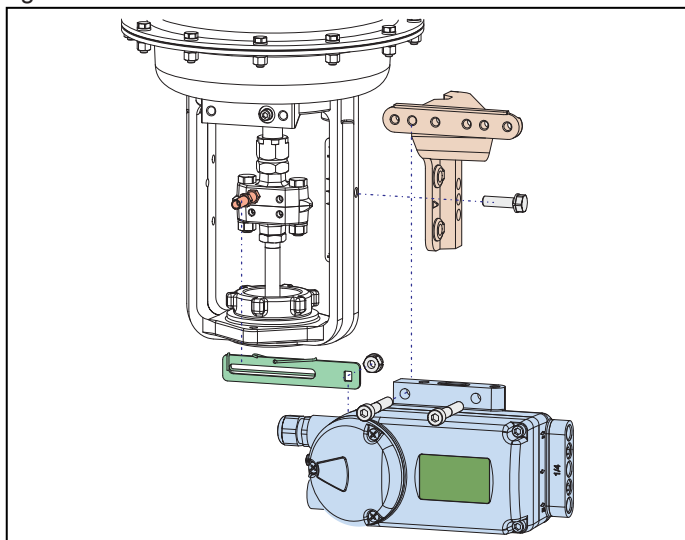

Attachment of the positioner to the actuator is made to the right using the mounting bracket and feedback lever for a NAMUR mount. Use:

attachment kit EBZG -H for a cast yoke, or attachment kit EBZG -K for a pillar yoke.

The side outputs I (or I and II) are used.

Pneumatic connections: Do not use Teflon tape for sealant. The fine fibres could disturb the function of the SRD. Use only Loctite® #243 for sealant ¹⁾.

Screw-type glands for electrical connections are positioned on the side. Device is shipped with a closing sticker; remove sticker and mount a cable gland or, if unused, a closing plug.

4.2.1 Preparation of the positioner

Rotate the shaft stub of shaft **9** so that the flat on the shaft stub is perpendicular to the arrow **26** on the housing at mid travel range. Fasten the feedback lever **A** to the shaft by means of spring washer and nut M8.

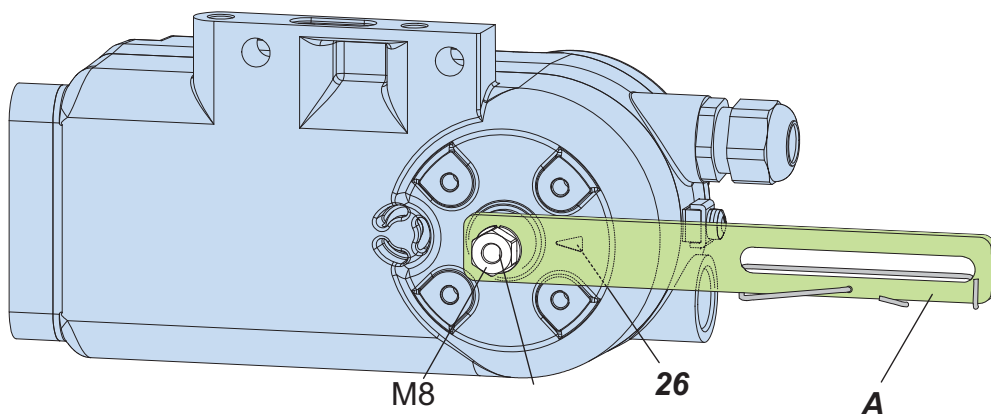

4.2.2 Preparation of the actuator

Screw the carrier bolt to the stem connector (see page 12) and lock it by means of a counter nut.

A carrier bolt with an adjustable length is used to be able to screw on various coupling pieces.

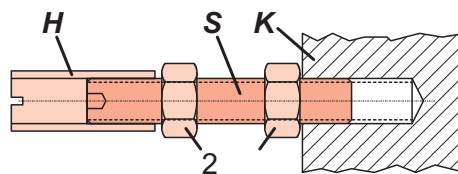

It consists of a stud S (size M6), which is screwed into the coupling piece K (with 3 mm Allen key) and locked with a lock nut 1. The threaded sleeve H is screwed onto it and locked with a lock nut 2. Make sure that the bolt is adjusted to the right length!

Fasten the mounting bracket to the left side of the yoke.

For a cast yoke use a screw M8 x 30, for a pillar yoke use two U-bolts and four nuts.

4.2.3 Mounting of the positioner

Fasten the positioner to the mounting bracket using two spring washers and two screws M8 x 80.

Note, the carrier bolt **B** is in the slot of the feedback lever **A** and the compensating spring **F** touches the carrier bolt.

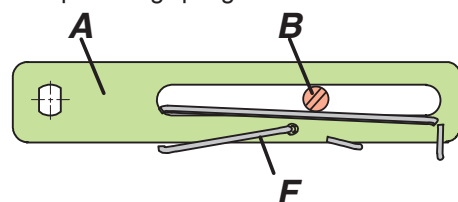

Fig.: Feedback lever

For optimum utilization of the positioner operating range, it is recommended the arrangement be adjusted according to the following procedure before fixing. At an actuator position in the middle of travel range, the feedback lever position should be perpendicular to the actuator stem and the angle range should be between $\pm 10^\circ$ and $\pm 45^\circ$.

Fasten the positioner to the mounting bracket so that a suitable angle range is selected.

It is recommended that the pneumatic and electrical connections are made after adjusting the position.

1) Apply only to male thread

4.2.4 NAMUR Mounting Dimensions – right hand -

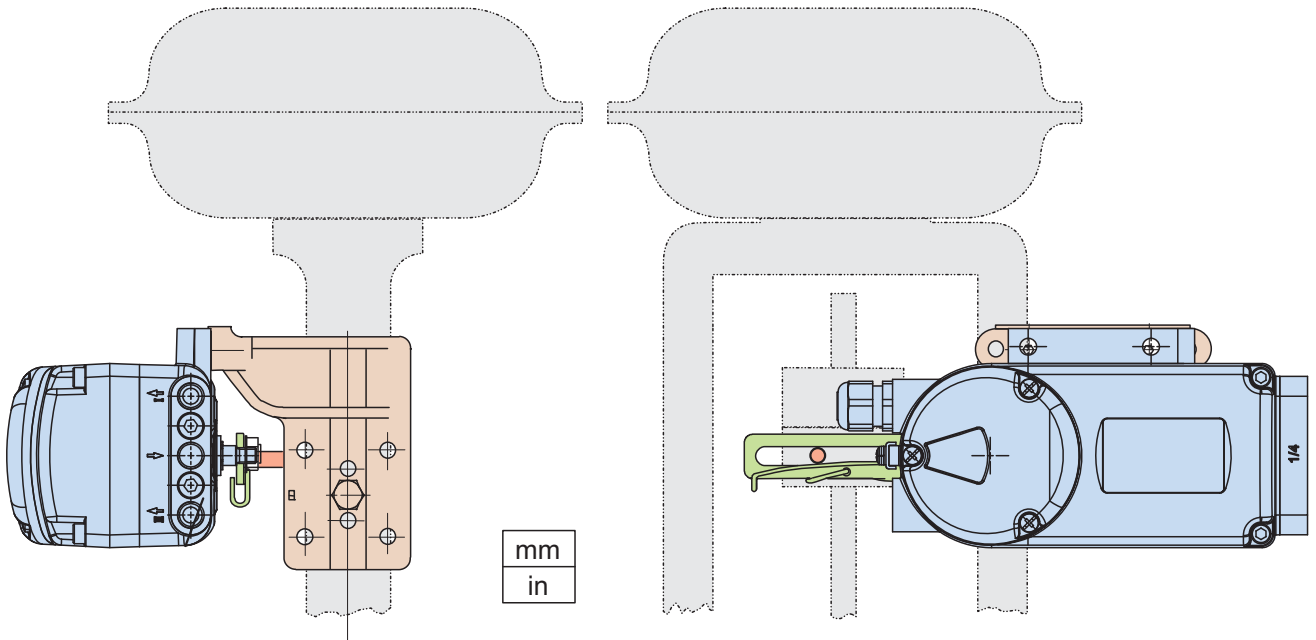

Attachment to casting yoke
(with attachment kit EBZG-H)

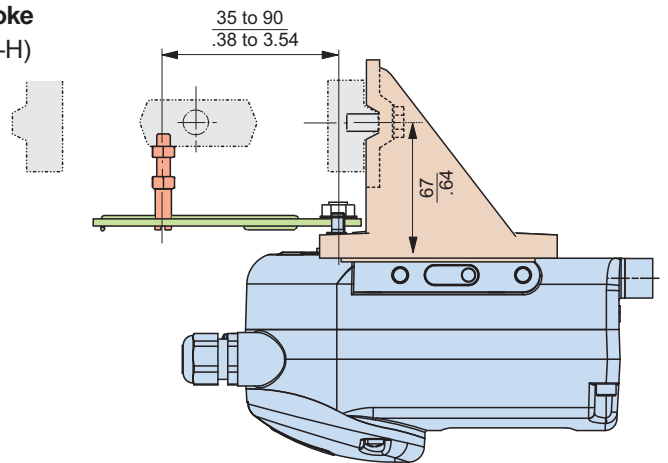

Feedback lever and carrier bolt see page 12

Attachment to pillar yoke
(with attachment kit EBZG-K)

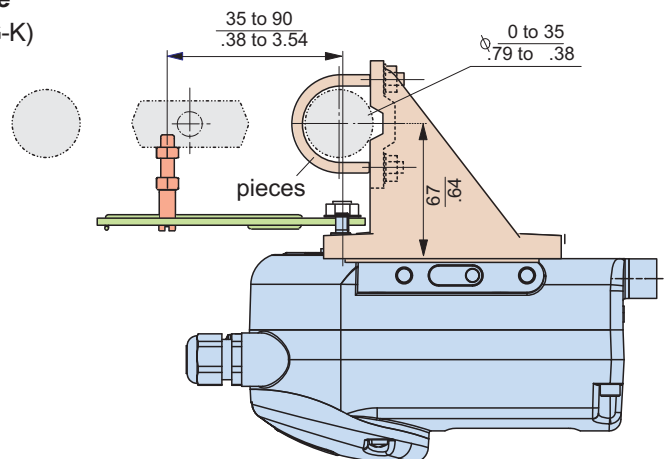

DIMENSIONS

Components of Attachment kits (samples)

Feedback lever Code EBZG-A for 8 to 70 mm travel

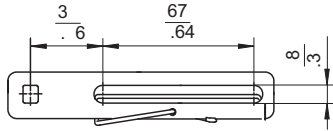

Feedback lever Code EBZG-B for 60 to 120 mm travel

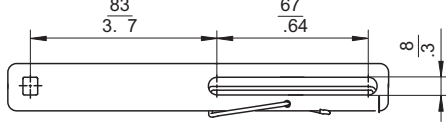

Feedback lever FlowPak/FlowTop in Code EBZG-E

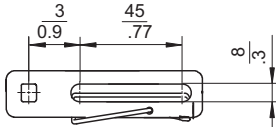

Feedback lever Code EBZG-A1 for 100 to 260 mm travel

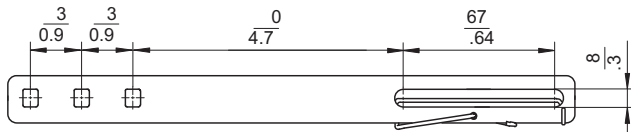

Carrier bolt for connection to valve stem

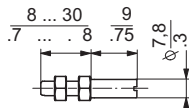

Mounting bracket

e.g. EBZG -H -K

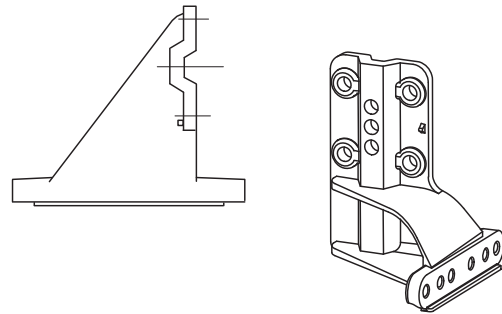
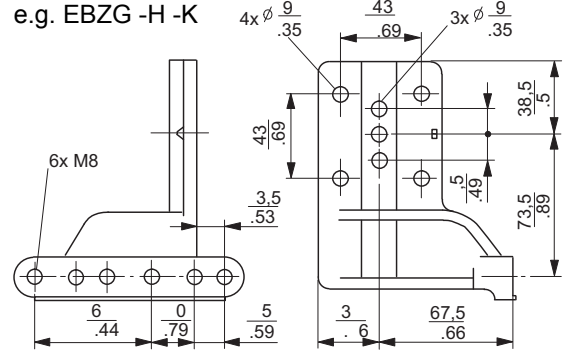

mm
in

4.4 Mounting to rotary actuators

Applicable to rotary actuators that meet the VDI/VDE 3845 standard for mounting. Installation position of positioner: Mount the positioner so that the pneumatic connections are in the same direction as the longitudinal drive axis of the actuator as shown in the illustration below.

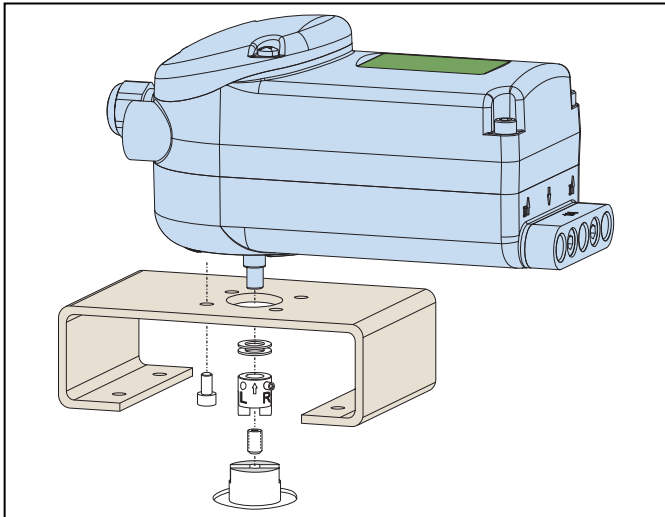

Attention: The feedback shaft 9 of the SRD has no mechanical stop, therefore may spin 360 degrees. The permissible rotation angle range is between +50 and -50 degrees around the arrow at the housing concerning the flat area of the feedback shaft (see detail previous page, bottom). Since a rotary actuator has a rotary angle of about 90 degrees the mounting as described in the following must be carried out very precisely.

Attachment of the positioner to the actuator is made by using the rotary adaptor kit EBZG -R.

The side outputs I (or I and II) are used.

Pneumatic connections: Do not use Teflon tape for sealant. The fine fibres could disturb the function of the SRD. Use only Loctite® #243 for sealant 1).

Screw-type glands for electrical connections are used as needed. Any unused threaded holes are closed by plugs.

Caution! Prevent accumulation of water in the instrument in this mounting position by sealing cable entry against water. Provide a continuous supply of dry instrument air.

4.4.1 Preparation of positioner

Valve must be in failsafe position and the direction of rotation of the actuator drive shaft must be known. These items are extremely important for proper functioning. These items can be checked as follows in case they are not clear:

In the single acting actuator the force of the installed spring closes. The pressure-less actuator is in failsafe position. Through manually feeding compressed air it can be seen whether the actuator drive shaft rotates to the left or to the right.

In the double acting actuator (without spring reset) both air chambers are basically equal. Failsafe position can be either "open" or "close". Therefore, indication of the failsafe position has to be determined by engineering. Then the direction of rotation may be determined by manual feeding of compressed air.

See next page: Bolt 2 is screwed into actuator drive shaft 1 for subsequent centering of the rotary adaptor 3. The attachment console is mounted to the rotary actuator.

Attachment diagram for bracket

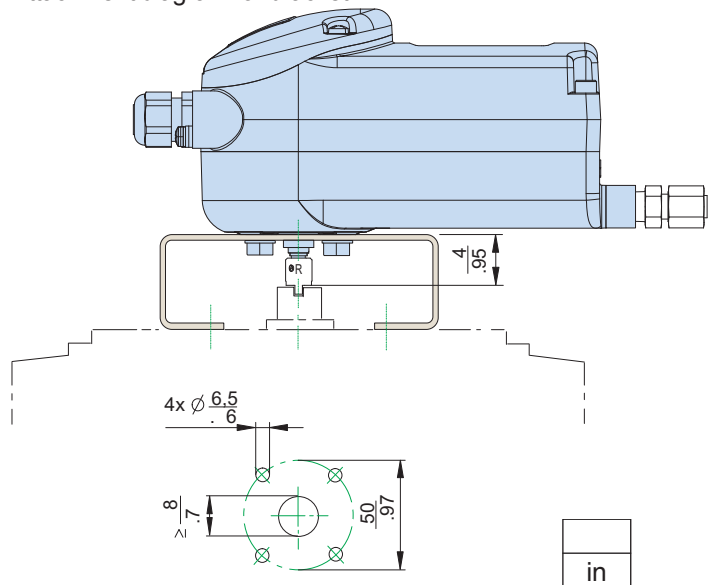

Rotary adaptor

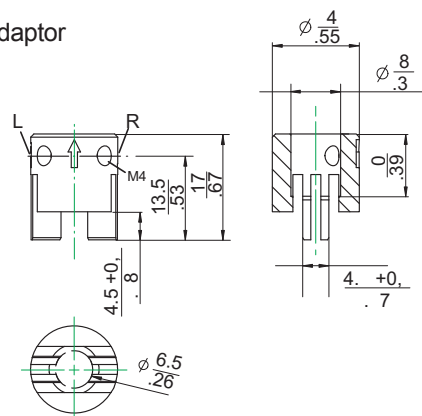

1) Apply only to male thread.

4.4.2 Preparation of the actuator

First the rotary adaptor is being prepared:

- For attachment to a counter-clockwise or left turning actuator secure the stud screw **4** in the threaded hole "L" of the rotary adaptor; hole "R" remains open. See Fig. 27.
- For attachment to a clockwise or right turning actuator secure the stud screw **4** in the threaded hole "R" of the rotary adaptor; hole "L" remains open. See Fig. 28.
Stud screw should always be tightened into the flat on the on the feedback shaft **9**.

Now place the rotary adaptor **3** with two washers **5** on the feedback shaft **9** of the positioner against the stop.

Note :

When the product temperature rises, the drive shaft **1** becomes longer. Therefore, the rotary adaptor **3** must be mounted so that approx. 1 mm (0.04 in.) of clearance results between the drive shaft **1** and the rotary adaptor **3**. This is achieved by placing an appropriate number of washers **5** on the feedback shaft stub **9** before attaching the rotary adaptor. Two washers should result in a clearance of 1 mm.

Now screw and tighten the bolt in the coupling against the flat part of the feedback shaft (do not screw against thread!).

Finally turn the feedback shaft in such a way that the arrow of the coupling points to the arrow of the SRD housing. Beginning and end positions of the actuator drive shaft **1** and feedback shaft **9** are marked in figure 27 (left-rotating actuator) and in figure 28 (right-rotating actuator) by arrows for the respective direction of rotation. The feedback shaft is now in the normal position corresponding to the failsafe position of the actuator.

4.4.3 Mounting of positioner

SRD and actuator are in failsafe position.

Attach the SRD on the console in such a way that the catch of coupling **3** is guided into the groove of shaft **1**. Use bolt **2** to center and align the positioner to the actuator. Be careful not to shift shafts **1** and **9** and that both shafts are exactly flush.

Fasten the positioner to the bracket by means of 4 lock washers and 4 screws M6 x 12.

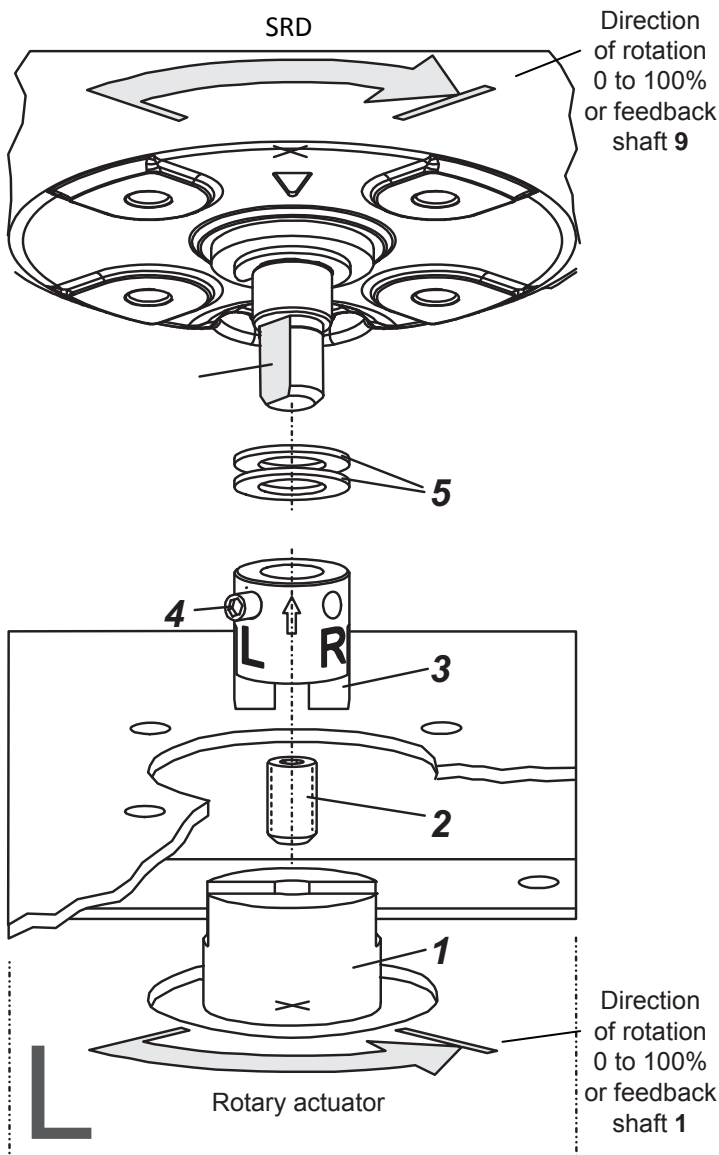

Figure 27: Mounting if actuator is left-rotating

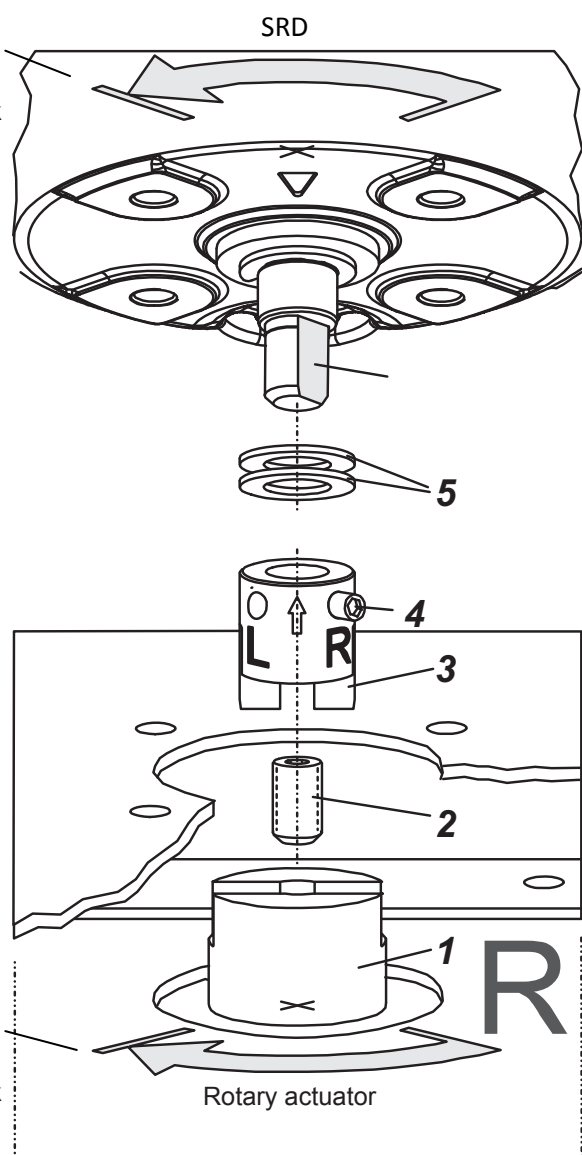

Figure 28: Mounting if actuator is right-rotating

5 PNEUMATIC CONNECTIONS



WARNING

To avoid any personal injury resulting from bursting of parts, do not exceed maximum supply pressure of positioner and actuator. To avoid any personal injury or property damage from sudden or fast movement, during air connection: Do not put your finger or other part at any time inside the valve or in any moving part of the actuator. Do not put your finger or other part at any time in the feedback lever mechanism. Do not touch the rear part of the positioner at any time. Connect air supply only after connection Y1 (and Y2 for double acting) are done.

Following alignment and mounting of the positioner to the valve, pneumatic tubing has to be provided.

Explanation of abbreviations:

- s** Supply air
- y1** Output 1, depressurized at currentless electronics. When using this output **y1** has to be closed by means of sealing screw and O-ring.
- Y2** Output 2 for double-acting actuator. Full pressure at currentless electronics. Closed at single-acting actuator.
- n1** Hex. screw with NPT thread
Part No. 522 588 013 (stainless steel)
Part No. 556 446 016 (plastic)

Unused pneumatic connections must be closed off.

FAIL SAFE POSITION FOR DOUBLE ACTING

Fail safe position of the double acting valve is given by the fail safe action of the pneumatic of the positioner itself. In case positioner is de-energized (or OUT OF SERVICE or DEVICE FAULT):

- Output **Y1** is 0
- Output **Y2** is 100% of air supply pressure

Therefore do pneumatic piping of **Y2** to the chamber of the actuator that should be pressurized to do the requested fail safe. In any case put air supply only when the output **Y2** is connected.

Supply

- Supply air 1.4 to 6 bar (20 to 90 psig)
- Air supply according to ISO 8573-1
 - Solid particle size and density class 2
 - Oil rate class 3
 - Pressure dew point 10 K under ambient temperature

For air supply, we recommend a FRS02 / FRS03 / FRS923 filter regulator.

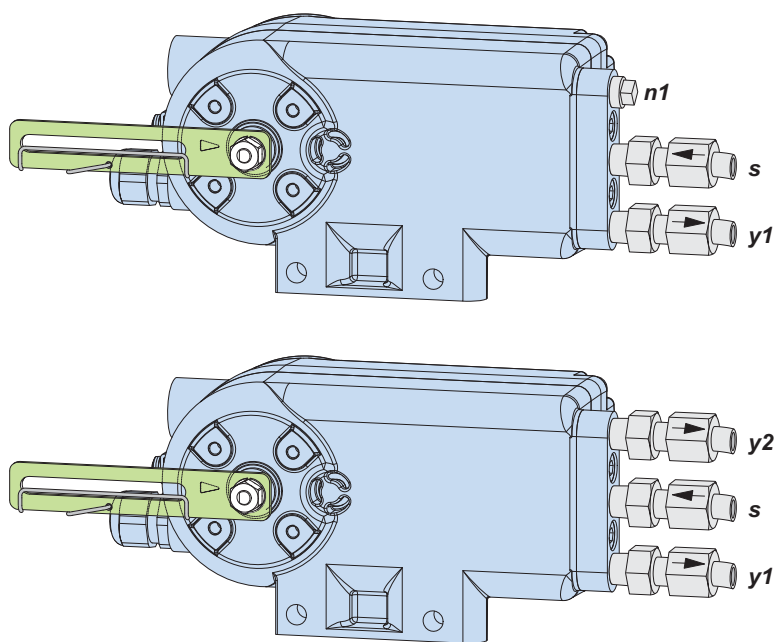

6 ELECTRICAL CONNECTION



WARNING

To avoid any electrical shock, respect the maximum input supply voltage for the device and options. To avoid any personal injury or property damage from sudden or fast movement, during electrical connection: Do not put your finger or other part at any time inside the valve or in any moving part of the actuator. Do not put your finger or other part at any time in the feedback lever mechanism. Do not touch the rear part of the positioner at any time.

Connection

Device is shipped with a closing sticker; remove sticker and mount cable gland **1** as required for proper installation concerning the certification requirements. Feed in the input cable through the gland. The gland is suitable for cable diameters of 6 to 12 mm (0.24 to 0.47 in). Check the tightness of the cable entry.

Make the electrical connection of the input line at the screw terminals **3**. The terminals are suitable for wire cross-sections of 0.3 to 2,5 mm² (22 -14 AWG) screwed with a maximum torque of 0.5 Nm.

The shield of the cable connection is

- with conductive cable glands (recommended) directly connected with the housing
- with non-conductive cable glands to be placed onto the inner screw terminal **4**.

Note: When connecting shielded cable connect the cable shield on both sides! (on the positioner side as well as on the system side).

For selection of cable, see recommendation for cable types acc. to IEC 1158-2.

For connection to a local ground the internal and external ground terminal **4** can be used. Tightening torque is 2 Nm.

To open cover

To remove cover from housing, loosen 3 screws **A**.

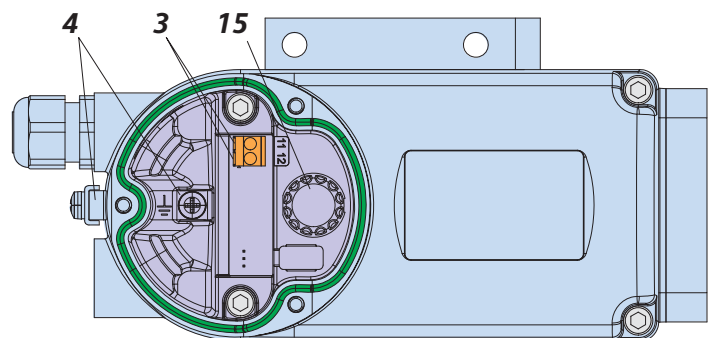
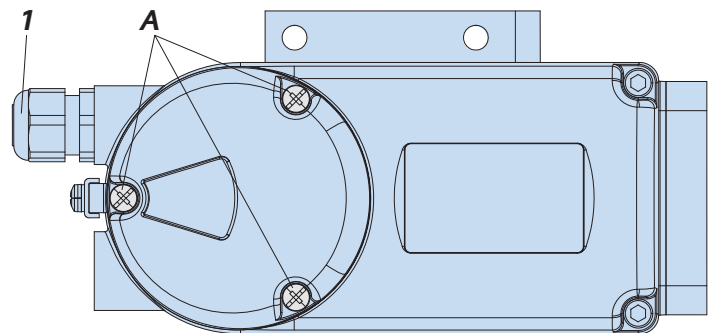

ELECTRICAL CONNECTION (continued)

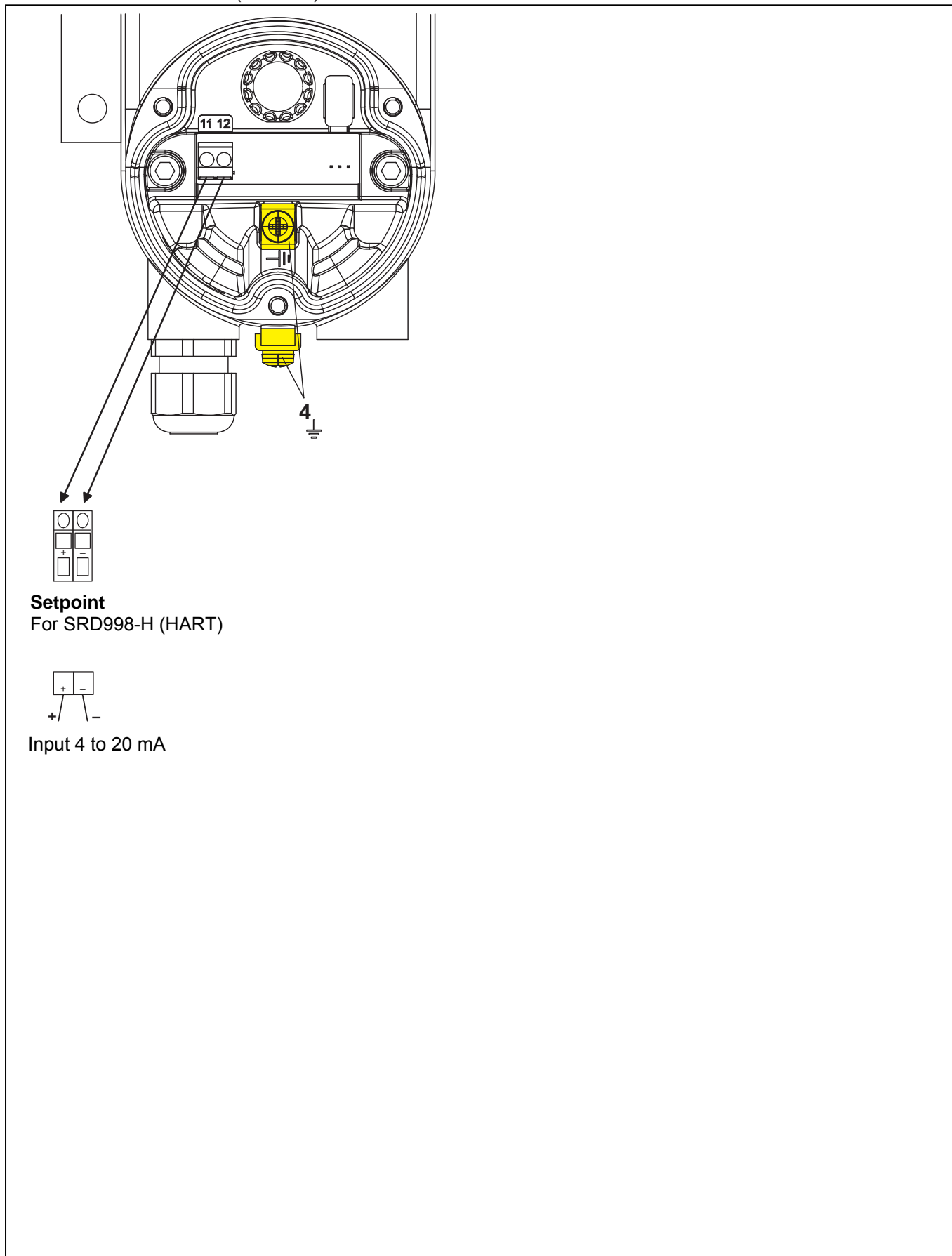

Setpoint
For SRD998-H (HART)

Input 4 to 20 mA

8 START-UP

WARNING

To avoid any personal injury or property damage at any time:

Do not put your finger or other part at any time inside the valve or in any moving part of the actuator or in the feedback lever mechanism. Do not touch the rear part of the positioner at any time.

General

First of all, **check** the nameplate, especially with respect to indications referring to Ex / non- Ex, input signal, communciation, output signal, single / double acting, etc.

Before starting the positioner, **mount** the SRD to the actuator and **connect power and air supply**.

The supply air connection must have sufficient capacity and pressure of 1.4 to 6 bar (20 to 90 psig) and should not exceed the maximum operating pressure of the actuator.

POWER ON

After power on of the input signal, the SRD initializes for a few seconds, while the various components of the electronics are checked and started. After power off / on cycle the stored data of the positioner is not affected, and remains unchanged.

After that, the SRD goes

- **IN OPERATION** or
- To configuration, if no Autostart has already been done, see next page.

8.1 OPERATION

After accomplished Autostart, the SRD automatically goes IN OPERATION.

On the LCD display the process variable is indicated.

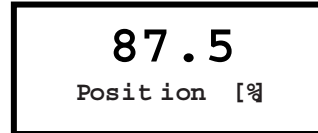

Through turning the Rotary Selector **15**, additional information can be retrieved from the SRD:

```
Position [%]
Input SP [%]
Work SP [%]
Current [mA]
*Angle [°]
*Position [mm] / [in]
Temperat [°C] / [°F]
Tags
Version
```

(* depending on mounted version)

Diagnostics during Operation

If the diagnostics determines an occurrence, it is indicated at the Status field in the bottom line:

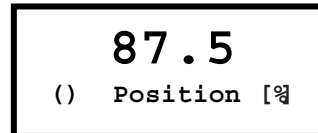

() Status field, see chapter "Trouble-shooting".

8.2 CONFIGURATION

WARNING

To avoid any personal injury or property damage from sudden or fast movement, during configuration and Autostart:

Do not put your finger or other part at any time inside the valve or in any moving part of the actuator. Do not put your finger or other part at any time in the feedback lever mechanism. Do not touch the rear part of the positioner at any time.

Attention: Configuration may interfere with operation of the actual process! During configuration it is recommended that there is no flow through the valve.

Configuration of SRD can be carried out via PC, HART communication and FDT/DTM software, or local with the Rotary Selector and LCD. This is described on the following pages.

After power ON, the SRD goes to configuration, if no Autostart has already been done.

Then first select LCD text language ...

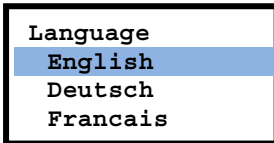

Select with Rotary selector and confirm by pushing it down ... and the display orientation is selected ...

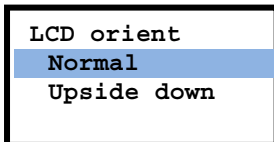

... then automatically continued to configuration

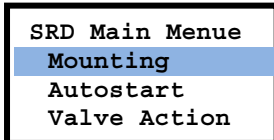

Configuration menus can always be reached by pushing down the Rotary selector **15**.

Setting by means of Rotary Selector and LCD

The SRD can be adjusted when the cover is off. To configure the various items, select the relevant menu by turning the Rotary Selector **15** and confirm by pushing it down.

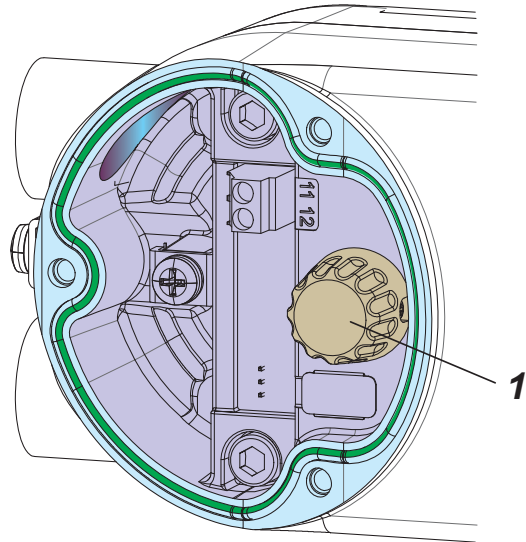

Indication with LCD

In totally intuitive text:

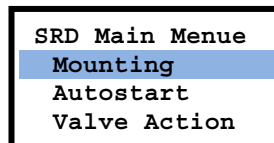

Most menus have submenus or parameters. Select the relevant menu by turning the Rotary Selector and confirm by pushing it down.

To leave any menu, select "Exit" and confirm.

If a menu was selected and no further entries are made thereafter, the SRD switches automatically back to operation after some minutes.

If there is no response using the Rotary Selector and LCD (message 1 appears) make sure that the Write Protection is not set ! Remove the write protection using the FDT/DTM configuration software or HART field communicator.

Menu structure for SRD998

SRD Main Menu

Menu	Factory configuration	Description	07.2016
1 Mounting			
1.1 Stroke left	✓	Stroke actuator, left-hand or direct mounting	
1.2 Stroke right		Stroke actuator, right-hand mounting	
1.3 Rotary ccw		Rotary actuator, opening counter-clockwise	
1.4 Rotary clockw		Rotary actuator, opening clockwise	
1.5 Linear Pot.		Mounting with external linear potentiometer	
2 Autostart			
2.1 Endpoints		Adaptation of the mechanical stops only	
2.2 Standard		Autostart recommended for standard application	
2.3 Extended		Enhanced Autostart. Optimized control behaviour compared to Standard Autostart	
2.4 Smooth response		Extended Autostart. Dampened control behaviour for smaller actuators	
2.5 Fast response		Extended Autostart. Undampened control behaviour for larger actuators	
3 Valve Action			
3.1 SRD		Action of Positioner:	
3.1.1 Direct	✓	Valve opens with increasing setpoint value	
3.1.2 Reverse		Valve closes with increasing setpoint value	
3.2 Feedback		Action of Feedback unit:	
3.2.1 Direct	✓	Increasing Current with increasing valve position	
3.2.2 Reverse		Decreasing Current with increasing valve position	
4 Accessories			
4.1 None		No accessories mounted	
4.2 Booster		Booster mounted	
5 Valve character			
5.1 Linear	✓	Linear characteristic	
5.2 Equal % 1:50		Equal percentage characteristic 1:50	
5.3 Quick open		Inverse equal percentage characteristic 1:50 (quick opening)	
5.4 Custom		Custom characteristic (configuration via DTM)	
6 Limits/alarms			
6.1 Lower limit	0 %	Closing limit is set to input value	
6.2 Cutoff low	1 %	0%-tight sealing point is set to input value	
6.3 Cutoff high	100 %	100%-tight sealing point is set to input value	
6.4 Upper limit	100 %	Opening limit is set to input value	
6.5 Split-range 0 %	4 mA	Split range 0 %: input value corresponds to 0 %	
6.6 Split-mg 100 %	20 mA	Split range 100 %: input value corresponds to 100 %	
6.7 Lower Alarm	-10 %	Lower position alarm on output 1 is set to input value	
6.8 Upper Alarm	110 %	Upper position alarm on output 2 is set to input value	
6.9 Valve 0%	4 mA	Configuration of rated-stroke of 0% at 4 mA	
6.10 Valve 100%	20 mA	Configuration of rated-stroke of 100% at 20 mA	
6.11 Pos Tuning		Tuning of position for mounting adaption	
6.12 Stroke	x° / 20mm	Configuration of nominal travel	

Continued on the next page

7 Tuning			
7.1	P closing	15	P: Proportional gain for 'close valve'
7.2	P opening	2	P: Proportional gain for 'open valve'
7.3	I closing	7.5	I: Integration time for 'close valve'
7.4	I opening	2.4	I: Integration time for 'open valve'
7.5	D closing	0.35	D: Derivative time for 'close valve'
7.6	D opening	0.35	D: Derivative time for 'open valve'
7.7	Trav time close		Positioning time for 'close valve'
7.8	Trav time open		Positioning time for 'open valve'
7.9	Control gap	0.1	Permitted neutral zone for control difference
7.10	Booster tuning		Fine tuning of control for booster applications
8 Output			Manual setting of IP-Module for testing of pneumatic output
9 Setpoint			Manual setting of valve position:
9.1	12.5% Steps		Setpoint changes of 12.5% steps by turning Rotary Selector
9.2	1% Steps		Setpoint changes of 1% steps by turning Rotary Selector
9.3	Do PST		Starts the Partial Stroke Test, with the given parameters by DTM
10 Workbench			
10.1	Reset to fact		Resetting of configuration to settings "ex factory"
10.2	Go in operation		Service function: Start of controller w/o Autostart. Not for regular use
10.3	Language		Language on LCD:
10.3.1	English	✓	Standard, English
10.3.2	Deutsch		Standard, German
10.3.3	Français		Standard, French
10.3...	& more		
10.4	LCD orient		Orientation of LCD:
10.4.1	Normal	✓	Normal orientation of writing on LCD
10.4.2	Upside down		Reverse orientation of writing on LCD
10.5	LCD contrast		
10.6	Units		Configuration of temperature and pressure unit SI or Anglo US
10.6.1	SI (metric)	✓	
10.6.2	Imperial (US)		
11 not with HART			
11 Profibus PA - Bus address			
11.1	Address LSB		Ratio from Dec. 0 / Hex 00 to Dec. 15 / Hex 0F
11.2	Address MSB		Ratio from Dec. 0 / Hex 00 to Dec. 112 / Hex 70
11.3	Address	126	Display of Bus Address from Dec. 1 to 127 (Hex 00 to 7F)
11 FOUNDATION Fieldbus H1			
11.1	Simulate		
	Disabled	✓	Simulate disabled
	Enabled		Simulate enabled
11.2	Profile		
	Link Master	✓	Link Master active
	Basic Device		Link Master de-activated

8.4 Description of menus

Because of optimised local operation, for configuration neither PC nor control system is required.

In case operation via Rotary Selector is not possible check if write protection is set.
Change via FDT/DTM software.

Menu 1: Actuator system, Mounting side



WARNING

To avoid any personal injury or property damage from sudden or fast movement, during configuration:

Do not put your finger or other part at any time inside the valve or in any moving part of the actuator. Do not put your finger or other part at any time in the feedback lever mechanism. Do not touch the rear part of the positioner at any time.

For an optimal actuator adaptation the SRD has to be configured whether it is a rotary or a linear stroke actuator.

The positioner of the **rotary** actuator can work directly with the linear position sensor value. In case of a **stroke** actuator an error $\tan(\alpha)$ arises due to the angle of the resulting in 1% non-linearity at travel of 30°. The SRD is able to correct the travel via the tan function and thus avoid bigger linearity errors.

The rotation direction of the adapter shaft for the tap changes depending on the mounting side of the stroke actuator. "Valve closed" in one case means "Valve open" in another one.

There are rotary actuator types opening in the counter clockwise direction and others opening in the clockwise direction. This also has to be signaled to the SRD so that 0% "Valve closed" and 100% "Valve open" are correctly assigned.

For stroke actuators mounted left of the spindle resp. directly mounted.

Select with Rotary Selector and confirm by pushing it down.

For stroke actuators mounted right of the spindle.

For rotary actuators opening the valve during counter clockwise (left) rotation.

For rotary actuators opening the valve during clockwise (right) rotation.

For positioners with an external linear potentiometer instead of the rotary potentiometer.

SRD Main Menue
Mounting
Autostart
Valve Action

Select with Rotary Selector and confirm by pushing it down

Mounting
Stroke left
Stroke right
Rotary ccw

Further with turning Rotary Selector

Mounting
Stroke left
Stroke right
Rotary ccw

Mounting
Stroke left
Stroke right
Rotary ccw

Mounting
Stroke right
Rotary ccw
Rotary clockw

Mounting
Rotary ccw
Rotary clockw
Linear Pot.

Configuration of 0 and 100%

Valid for single and double acting

Configuration requested					
MENU 1: "Mounting"				MENU 3.1: "Valve Action"	
1.1	1.2	1.3	1.4	3.1.1	3.1.2

Configuration of 0% and 100%	Input Signal Range	Stroke Left	Stroke Right	Rotary cclockw.	Rotary clockwise	Direct	Reverse
	4 mA = 0% 20 mA = 100 %	✓				✓	
	4 mA = 100% 20 mA = 0%	✓					✓
	4 mA = 0% 20 mA = 100 %		✓			✓	
	4 mA = 100% 20 mA = 0 %		✓				✓
	4 mA = 0% 20 mA = 100 %		✓			✓	
	4 mA = 100% 20 mA = 0 %		✓				✓
	4 mA = 0% 20 mA = 100 %	✓				✓	
	4 mA = 100% 20 mA = 0 %	✓					✓

Valid for single and double acting

Configuration requested					
MENU 1: "Mounting"				MENU 3.1: "Valve Action"	
1.1	1.2	1.3	1.4	3.1.1	3.1.2

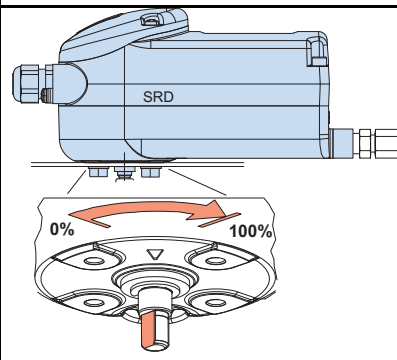
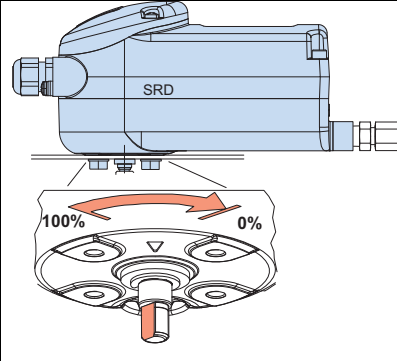
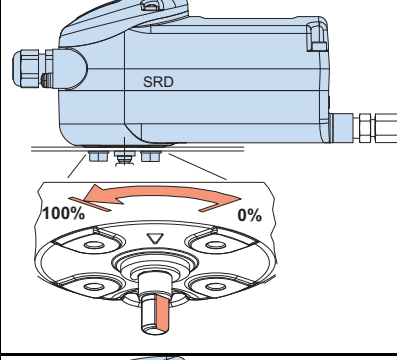
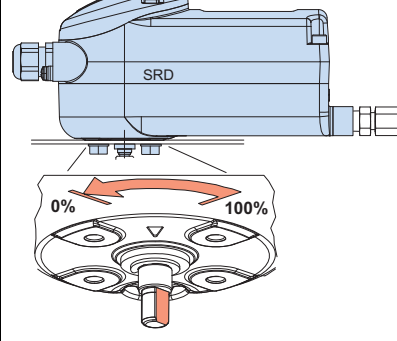
Configuration of 0% and 100%	Input Signal Range	Stroke Left	Stroke Right	Rotary cclockw.	Rotary clockwise	Direct	Reverse
	4 mA = 0% 20 mA = 100 %			✓		✓	
	4 mA = 100% 20 mA = 0%			✓			✓
	4 mA = 0% 20 mA = 100%				✓	✓	
	4 mA = 100% 20 mA = 0%				✓		✓
	4 mA = 0% 20 mA = 100%				✓	✓	
	4 mA = 100% 20 mA = 0%				✓		✓
	4 mA = 0% 20 mA = 100%			✓		✓	
	4 mA = 100% 20 mA = 0%			✓			✓

Menu 2: Autostart

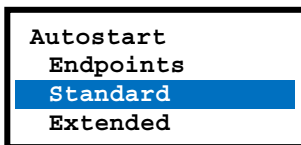
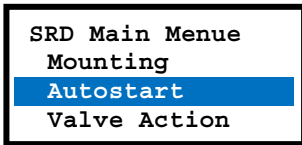

Further with turning Rotary Selector

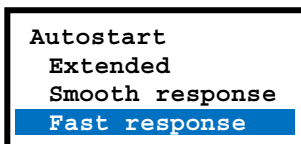

Selection between different Autostart modes (change by turning Rotary Selector and confirm by pushing it down):

Autostart:

To automatically adapt the positioner to the valve. Geometric data of the actuator is determined and optimally assigned to control parameters. If the "Standard" Autostart does not result in stable control, another Autostart mode - depending upon actuator - should be selected. At **initial start-up**, an Autostart should always be performed.

Attention: Autostart overwrites previous control parameters!

Ready for "End points" Autostart:

Serves for reduced automatic adjustment of the SRD to only the mechanical end points.

Ready for "Standard" Autostart:

Serves for automatic adjustment of the SRD to the mechanical end points and to the optimization of the controller parameters.

Ready for "Extended" Autostart:

To the optimization of the controller parameters in relation to standard mode.

Ready for "Smooth response" Autostart:

Extended, damped controller parameters for smaller actuators.

Ready for "Fast response" Autostart:

Extended, undamped controller parameters for larger actuators.

WARNING

To avoid any personal injury or property damage from sudden or fast movement, during autostart:
Do not put your finger or other part at any time inside the valve or in any moving part of the actuator. Do not put your finger or other part at any time in the feedback lever mechanism. Do not touch the rear part of the positioner at any time.

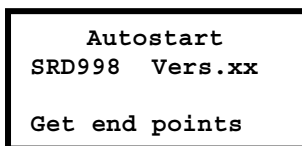

After selection and start (by pushing down Rotary Selector) the function taking several minutes can be followed at LCD. Duration on a valve position can take some time depending on actuator volume, air supply, pressure, etc.

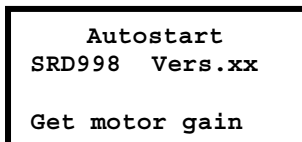

Moving direction, mechanical starting and ending positions are determined by one or several passages of valve position range.

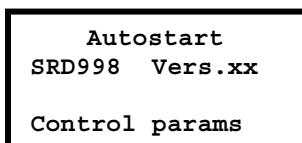

Ramps are entered and control system parameter is determined (ratio position / valve size).

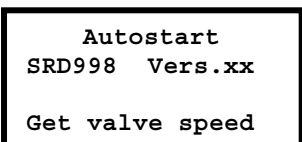

Jumps are entered for determination of control parameters.

Determination of positioning speeds.

Determined values are saved; previous values are superscribed. The SRD is IN OPERATION again with the detected new parameters.

Menu 3.1: Mode of Action of SRD

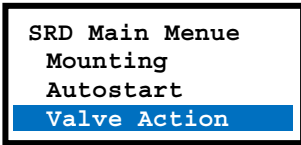

It will set the mode of action of the positioner.

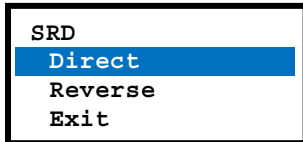

“Direct” if increasing input signal is to initiate increasing output signal. “Reverse” if increasing input signal is to initiate decreasing output signal.

Menu 4: Accessories

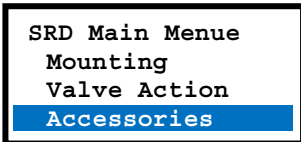

The presence of accessories can be configured.

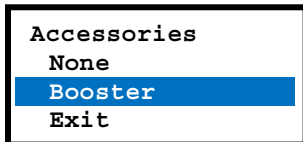

If a volume booster is present, select this point and confirm. Thus, the control algorithm of SRD will be adjusted automatically.

Menu 5: Characteristic of setpoint

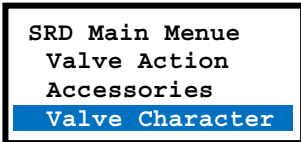

A relationship between the input signal and valve position is set.

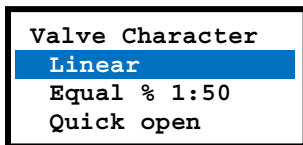

“Linear”. See Fig. 5.1

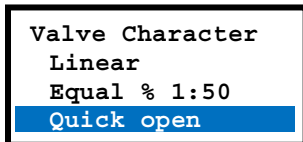

“Equal percentage”: Results in an equal percentage characteristic line with a position ratio of 1:50 for a valve of linear characteristic. See Fig. 5.2

“Quick open” (Inverse equal percentage): Results in an inversely equal percentage characteristic line with a position ratio of 50:1 for a valve of linear characteristic. See Fig. 5.3

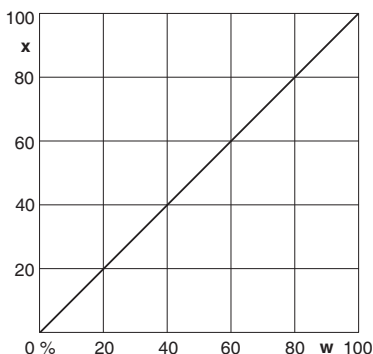

Fig. 5.1

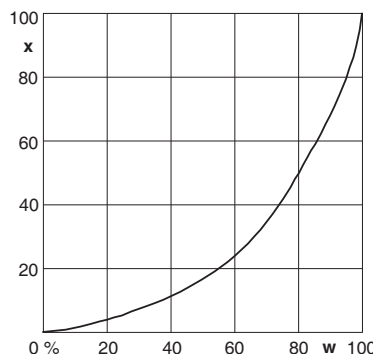

Fig. 5.2

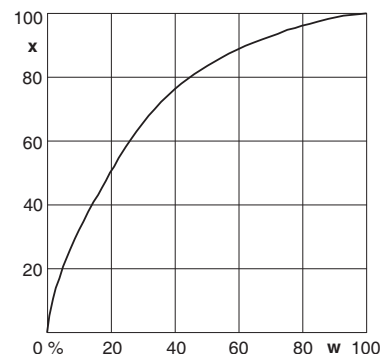
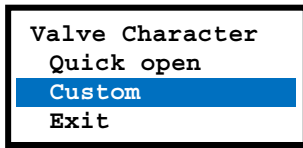

Fig. 5.3



„Custom“ (User defined characteristic):
A characteristic line entered via communication with 2 or 22 supporting points is activated.
Ex-factory a linear characteristic is set.

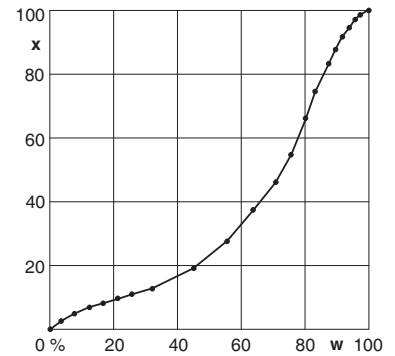
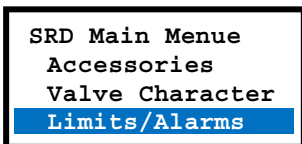

Fig. 5.4

Menu 6: Limit and Alarms of valve

The values can be adjusted stepwise locally with Rotary Selector, or can also be configured via PC with DTM software.



Definitions

- Stroke, stroke range** of the membrane actuator is defined for rotary actuator as **angle, angle range**.
- 0 % position** is the mechanical impact at actually closed valve (caution if using handwheel and mechanically adjustable stroke limitation!)
- 100 % position** is the mechanical impact at actually open valve.
- Closing limit** is a lower limit set via software. In normal operation the valve will not close more than set here. Attention: In the event of failure of the auxiliary energy no controlling is possible, therefore the springs in the actuator will move the valve into safety position (for single acting actuator).
- Opening limit** is a upper limit set via software. In normal operation the valve will not close more than set here. Attention: In the event of failure of the auxiliary energy no controlling is possible, therefore the springs in the actuator will move the valve into safety position (for single acting actuator).
- Normal operation** (= IN OPERATION) means that the position is controlled to the 4-20 mA input signal.

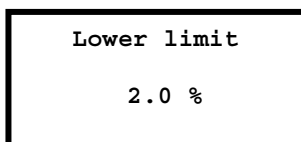
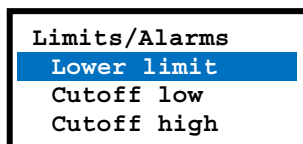

M 6.1 Setting Lower limit ("closing limit; cL")

The positioner provides that IN OPERATION the valve position does not close any further than defined by the closing limit. See Fig. 6c, 8d on next page.

If the setpoint value is lower than this limit, message 12 (see chapter "Trouble-shooting") is produced. Select menu by pushing down Rotary Selector, then turn to adjust value, and confirm.

Example: Lower limit is set to 2 %

```

Limits/Alarms
Lower limit
Cutoff low
Cutoff high
    
```

```

Cutoff low

3.0 %
    
```

```

Limits/Alarms
Lower limit
Cutoff low
Cutoff high
    
```

```

Cutoff high

97.0 %
    
```

```

Limits/Alarms
Cutoff low
Cutoff high
Upper limit
    
```

M 6.2 Setting Cutoff low ("0% seal-tight point; CO-L")

If a 0% seal-tight point is given, in case the setpoint is deviated lower (e.g. 3 %), the SRD provides the pneumatic output to press the valve into its seat with full force in order to tightly seal valve. See Fig. 6a, 6b. As soon as the command value is 0.5%* higher than this seal-tight value the position again follows the command value.

* This is the "Seal-tight hysteresis" factory set at 0.5 %. The value may be changed via communication.

Example: Cutoff low is set to 3 %.

M 6.3 Setting Cutoff high ("100% seal-tight point; CO-H")

If a 100% seal-tight point is pre-set and in case a certain set value is exceeded (e.g. 97 %), the SRD provides that the pneumatic output presses the valve 100% into its seat with full force. See Fig. 6a, 6b. As soon as the command value is 0.5% lower than this seal-tight value, the position again follows the command value.

This function makes sense for 3-way valves.

Also both seal-tight points can be used in order to tightly close the respective shut-off path during partial operation.

Example: Cutoff high is set to 97 %.

M 6.4 Setting Upper limit ("opening limit; oL")

The SRD provides that IN OPERATION the valve position does not open any further than defined by the opening limit. See Fig. 6c, 6d.

If the set value is exceeded, a message is produced.

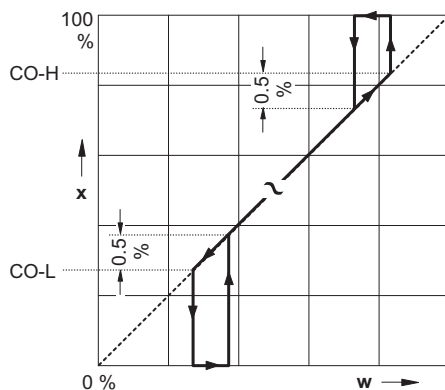

Fig. 6a: Sealing tightly, linear characteristic

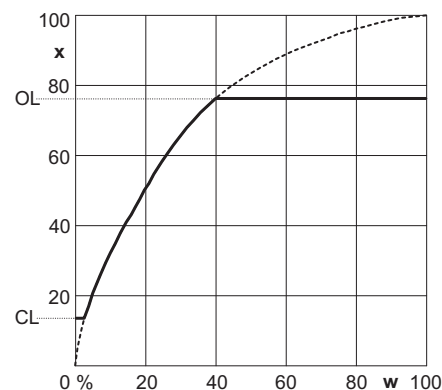

Fig. 6b: Sealing tightly, inversely equal percentage

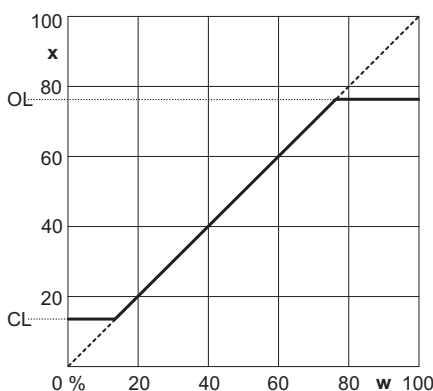

Fig. 6c: Opening and closing limits, linear characteristic

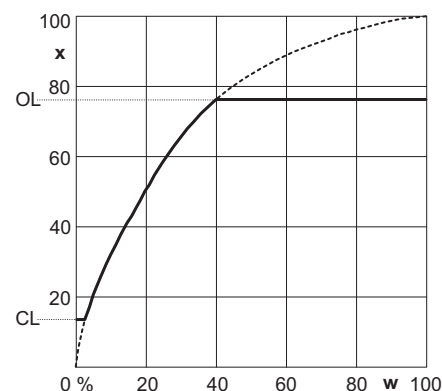
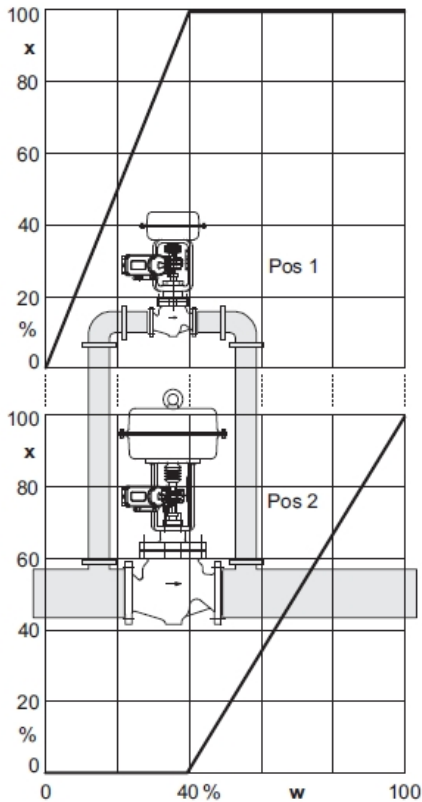

Fig. 6d: Opening and closing limits, inversely equal percentage characteristic

Split Range



SRD with HART communication

```
Limits/Alarms
Upper limit
Split-range 0%
Split-rng 100%
```

```
Limits/Alarms
Upper limit
Split-range 0%
Split-rng 100%
```

```
Splitr 100 %
10.4 mA
```

Split-Range, PV_Scale Splitting

Split Range is useful if an additional control range is demanded which cannot be covered by one valve only. A valve of smaller nominal size can be applied overtaking the smallest quantities; a parallel mounted valve of bigger nominal size takes on the larger quantities.

With conventional positioners, this function is realized through serial connection of the instruments and allocation of individual regulating ranges (see drawing). With SRD with analog setpoint value (version HART), this can be adjusted with menus 6.5 and 6.6.

Other versions of the SRD receive the set value via digital means; the input data signal cannot be splitted. The function can be realized either in the primary control system, in which setpoint values are calculated for each valve, or via the variables PV_SCALE. With PV_Scale the digital input setpoint value can be assigned to the valve span.

Example: At low current, only the smaller valve positions; from approx. 40 % the large valve is added. Values see bottom of page.

M 6.5 Split Range 0 %

Select menu by pushing down Rotary Selector, then turn to adjust value, and confirm.

M 6.6 Split Range 100 %

Select menu by pushing down Rotary Selector, then turn to adjust value, and confirm.

Example: An input current of 10.4 mA has to correspond to a valve position of 100 %

Values for example in the upper illustration:

Pos. 1: Split Range 0 % → 4 mA; Split Range 100 % → 10.4 mA
 Pos. 2: Split Range 0 % → 10.4 mA; Split Range 100 % → 20 mA

```

Limits/Alarms
Splitr 100 %
Lower Alarm
Upper Alarm

```

```

Limits/Alarms
Splitr 100 %
Lower Alarm
Upper Alarm

```

```

Upper Alarm

91.3 %

```

```

Limits/Alarms
Valve 0 %
Valve 100 %
Pos tuning

```

```

Limits/Alarms
Valve 0 %
Valve 100 %
Pos tuning

```

```

Valve 100 %

98.4 %
Confirm

```

```

Limits/Alarms
Valve 100 %
Pos tuning
Stroke

```

```

Limits/Alarms
Pos tuning
Stroke
Exit

```

```

Stroke

30.0 mm
1 in = 25.4 mm

```

Alarms (for future use)

M 6.7 Setting Lower Alarm

When falling below the set value underneath the entered alarm limit, an alarm is activated. Message 12 is generated.

To switch off the alarm setting, enter the value -10%.

M 6.8 Setting Upper Alarm

When surpassing the set value above the entered alarm limit, an alarm is activated. Message 13 is generated.

To switch off the alarm setting, enter the value +110%.

Select menu by pushing down Rotary Selector, then turn to adjust value, and confirm

Example: Upper Alarm set to 91.3 %.

Setting of Valve Limits

At Autostart the SRD determines the real limits of the actuator (which are mostly a little larger than specified on the specification sheet). An actuator with 30 mm stroke could display a real stroke of 33 mm. In order to produce a precise relationship between the input signal and the stroke, the tolerances of the actuator can be compensated with menus 6.9 and 6.10. At unchanged 0 %, the actuator could be moved until exactly 30 mm are reached. Through execution of function 6.10, the current position can be declared as 100 %, and at a setpoint value of 50 % the actuator will run on exactly 15 mm.

For new configuration of the strokes at 0 % or 100 %, the valve must be run in the corresponding position and then must be confirmed.

M 6.9 Setting Valve 0 %

The actual position of the actuator is declared as 0 %.

M 6.10 Setting Valve 100 %

The actual position of the actuator is declared as 100 %. Select menu by pushing down Rotary Selector, then confirm.

Example: The actual valve position 98.4 % is to be counted as 100 %.

M 6.11 Position tuning

Because of inaccuracies at mounting, it may be possible that at input value 50 % (= 12 mA) the stroke valve is not exactly at half of stroke, regarding scale at valve. To correct this, apply 12 mA and select this function. Move valve position to half of stroke by turning Rotary Selector, and confirm.

End points of stroke and $\tan(\alpha)$ values are automatically adapted and makes positioning even more precisely.

M 6.12 Setting Stroke with stroke actuators

The SRD measures with its feedback lever always an angle and by means of its tangent function, a linear stroke of 0 to 100 % is calculated therefrom. In order to indicate as well a real stroke in mm, the full stroke at 100 % can be entered in this menu. The LCD display will then indicate the actual position in mm (or inch).

Select menu by pushing down Rotary Selector, then turn to adjust value, and confirm.

Example: Stroke range of valve is to be 30 mm.

Menu 7: Parameter for tuning the Position controller

SRD Main Menu
Valve Character
Limits/Alarms
Tuning

Along with the determination of the actuator geometry and control parameters the suitable setting parameters for the position controller are determined via function AUTOSTART in Menu 2. Assessment of a control behavior generally is very subjective. Partially a quick response is requested without consideration of the overshoot width, partially a very smooth swinging is requested with minor overshoot.

We basically recommend to first perform the execution of the automatic setting via AUTOSTART in Menu 2 in order to achieve a stable control behavior. Corrections may then be made from the determined values.

In rare cases AUTOSTART cannot find the optimal setting for the respective application. See "Remarks for controller optimization" following next page.

For small actuators an improvement of the control behavior can be achieved also by increasing damping at the pneumatic output. A further optimization may follow by repeating AUTOSTART.

Several control parameters are combined in Menu 7 each having a submenu. Controller type is a PID controller.

Selection of tuning parameters:

Select sub-menu by turning Rotary Selector and confirm.

Tuning	Parameter-Description	Valve is opening	Valve is closing	Value	Unit
P closing P opening	Proportionate amplification KP	P↑	P↓	0 to100	-
I closing I opening	Integration time constant	Tn↑	Tn↓	0 to100	sec
D closing D opening	Derivative time constant	Tv↑	Tv↓	0 to100	sec
Trav time close Trav time open	Positioning time	T63↑	T63↓	0 to100	sec
Control gap	Dead band for control diff.	GAP	GAP	0 to10	% of span
Booster tuning	Fine tuning			0 to 2*	-

* Fine tuning: For boosters 0 to 2

The dead band prevents (at the expense of accuracy) that the valve in the controlled condition constantly moves around the setpoint. This reduces harm to the mechanical parts of the actuator and, in particular, the valve packing.

Remarks to Controller Tuning

If AUTOSTART does not find the optimum setting the following may be the result:

- A) slow response to setpoint, long positioning time or long neutral time
- B) continuous oscillation following setpoint jump
- C) wide and high overshoot

For the assessment of the control 12.5 % jumps in both directions may be performed in Menu 9. The valve dynamics may be observed at LCD or the mechanics.

Prior to changing parameters for valve dynamics a number of items are to be checked, see below. The pneumatic output can be operated directly without controller via Menu 8 and the valve movement may be assessed.

In case of behavior A) check:

1. Is the Proportionate gain $P\uparrow$ (Menu 7.1) or $P\downarrow$ (Menu 7.2) too small?
Remedy: Increase parameters.
2. Is the air pressure high enough to possibly overcome the actuator spring force and friction?
Remedy through increasing air pressure.
3. Is the actuator volume high, possibly requiring an increased air capacity for fast valve movement?
Remedy: through booster, see accessories, or spool valve option.
4. Was AUTOSTART performed in Menu 2 and did messages 8 resp. 9 occur?
Remedy: "AUTOSTART" in Menu 2 resp. observe information in chapter "Trouble-shooting".
5. Has the parameter for the positioning time been set at a value too high?
Remedy: decrease both parameters Setting Time in Menu 7.5 or 7.6 .
6. Is valve packing too tight resulting in a very high friction?
7. Is the supply air filter blocked?
Remedy: see chapter "Maintenance".
8. Has the supply air been contaminated by small oil drops, particulate or are pneumatic parts possibly blocked?
Remedy: exchange pneumatic parts; possibly use a suitable air supply station.

Behaviors B) and C) check:

1. Is the air capacity possibly too high, e.g. through spool valve or booster?
Remedy: Work, if necessary, without booster or use version without spool valve.
2. Has the air supply pressure been set too high? Remedy: Reduce pressure install pressure reducer.

Changing valve dynamics during behavior A):

If valve has a high friction (for example, often the case in small rotary actuators due to low air supply pressure or due to a valve seat packing which is too tight) then the valve position gets stuck after a setpoint jump and possibly is reconrolled via the resetting time T_n , possibly after quite some time has elapsed.

Basically, the following is possible:

- a) to accept a remaining deviation
- b) to accept some response procedures (such as remaining in over-response for a short time, and remaining below setpoint and trailing).

When deciding a), " T_n " should become ineffective, set value to "- off -". Compensating " $P(kp)$ " should be increased until the setpoint jumps reach the setpoint within a short period of time and without significant over-response (adapt to both movement directions).

When deciding b) start as in a) above. Thereafter " T_n " is reswitched and decreased until the setpoint deviation has been re-controlled within a short period of time and without long after-response (adapt in both movement directions). It is recommended to maintain the T_n 's for both directions about the same.

If a post oscillation occurs after a setpoint jump, " T_n " is selected too small, possibly " $P(kp)$ " was selected too large.

The positioning time Travel Time, also called valve damping, does not have an effect during AUTOSTART in Menu 2, however, setpoint jumps in Menu 9 reach the position controller in a damped condition which then is not easily stimulated to oscillation. This behavior is also true for the setpoint input.

This enables setting the controller to higher " $P(kp)$ " values without producing oscillations in the process. On one side this helps the position control to level disturbances due to friction, changes in load or air supply pressure changes faster. On the other hand it helps the superimposed valve control circuit that neutral times in the valve control route do not have such a big effect (stability in valve control circuit).

Changing valve dynamics during behavior B):

Increase " T_n " for both movement directions, possibly turn-off and proceed as described in behavior A) alternative b).



WARNING To avoid any personal injury or property damage from sudden or fast movement, during use of Menu 8 pneumatic output: **Do not put your finger or other part at any time inside the valve or in any moving part of the actuator. Do not put your finger or other part at any time in the feedback lever mechanism. Do not touch the rear part of the positioner at any time.**

Menu 8: Pneumatic output
(for trouble-shooting)

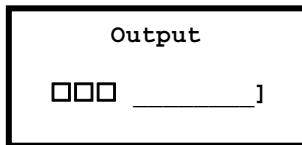
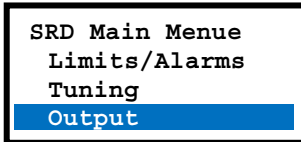

etc.

Serves to check the pneumatic parts of the positioner and the right valve piping by directly applying current to the IP module by turning the Rotary Selector (no control; software limit values such as “stroke limits” or “tight closing” are ignored).

The current of the IP module is increased by about 3 % in 32 steps. By measuring the output pressure generally the following characteristic line of the IP module is achieved. The ramp also may be more steep or flat depending on the air supply pressure.

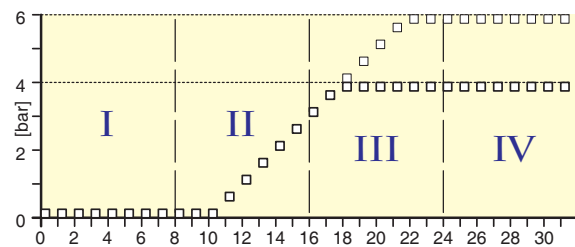

The pneumatic works precisely, if the actuator begins movement in section II and runs latest in section IV into the end position.

If no reaction is own, check:

- Does air supply exist? - Is plug connected to IP module?
- If these items are okay, possibly the electronics or a pneumatic part is defective. See also chapter “Trouble-shooting”. After leaving this menu (by pushing down Rotary Selector) the positioner continues to control with present setpoint at input.



WARNING To avoid any personal injury or property damage from sudden or fast movement, during use of Menu 9 pneumatic output: **Do not put your finger or other part at any time inside the valve or in any moving part of the actuator. Do not put your finger or other part at any time in the feedback lever mechanism. Do not touch the rear part of the positioner at any time.**

Menu 9: Manual setting of valve position

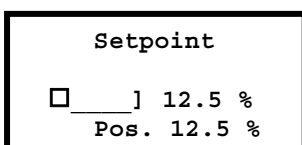
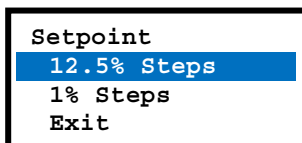
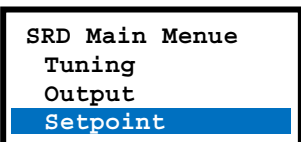

etc.

For the purpose of checking the control reaction of the actuator to a setpoint jump can be observed. As far as the device is IN OPERATION jumps of 12.5 % (or 1 %) each are initiated by turning Rotary Selector.

The starting value for Menu 9 is always the current setpoint value.

If the control behavior is to be improved, this can be reached by performing a complete Autostart (see Menu 2) or through manual tuning (see Menu 7).

After leaving this menu the positioner continues to control with present setpoint at input.

Menu 10: Workbench

```
SRD Main Menu
Output
Setpoint
Workbench
```

```
Workbench
Reset to Fact
Go in operation
Language
```

```
Workbench
Reset to Fact
Go in operation
Language
```

```
Workbench
Reset to Fact
Go in operation
Language
```

```
Language
English
Deutsch
Francais
```

```
Workbench
Go Online
Language
LCD orient
```

```
LCD orient
Normal
Upside down
```

```
Workbench
LCD orient
LCD contrast
Units
```

```
Workbench
LCD orient
LCD contrast
Units
```

Menu 11: Exit

```
SRD Main Menu
Setpoint
Workbench
Exit
```

Miscellaneous functions.

M 10.1 Reset Configuration to “ex factory” settings

Resets all entries made in all menus to the standard values present at delivery. This may become necessary if it is unclear what had been changed per menu or in the event that a positioner was taken from one actuator and mounted to another actuator.

After these functions the device is turned to condition OUT OF SERVICE. Therefore an Autostart has to be carried out after configuration of menus 1 to 6. Tuning with menus 7 if necessary.

M 10.2 Go IN OPERATION without Autostart

In principle, the first startup runs an Autostart in which the SRD is optimally adapted to the actuator, then the SRD goes IN OPERATION and begins to control.

This service function sets the SRD directly IN OPERATION, without an Autostart. Only for test purposes. Not recommended for regular use.

M 10.3 Selection of menu language

One of the programmed languages can be selected.

Ex-factory the active language is always English. Changing to one of the other languages can also be done during operation.

Select menu by pushing down Rotary Selector, then turn to select language, and confirm by pushing it down.

M 10.4 LCD Orientation

Display normal or turned by 180°.

```
LCD orient
Upside down
Normal
LCD orient
```

M 10.5 LCD contrast

For adjustment of contrast / brightness of display.

M 10.6 Selection of SI or Imperial units

SI: Dimensions in mm, and temperatures in °C
Imperial: Dimensions in inch, and temperatures in °F

M 11 Exit

End of configuration and back to operation.
Confirm by pushing down the Rotary Selector.

Additional Parameters

The following parameters are accessible via communication only

Parameter	ex factory
Control difference limit value	5 %
Control difference response time	1 min
Cutoff hysteresis	0.5 %
Failsafe action	OFF
Power-up action	OUT OF SERVICE
Parameter write protection	OFF
Alarm limit for total strokes	90 Mio.
Alarm limit for total cycles	90 Mio.
Dead band for valve cycles	1 %
Upper pre-alarm	100 %
Lower pre-alarm	0 %
Hysteresis for position alarms	0.5 %

Complete parameter list see FDT/DTM Software.

9 DECOMMISSIONING

Before decommissioning the unit, disconnect the supply air and the electrical input signal.

After disconnecting the electrical input signal the last confirmed configuration of the positioner is preserved in the memory.

Exchange of device

If a temporary decommissioning of the SRD and a later mounting to another actuator has to be carried out, before disconnecting, we recommend to Reset Configuration in Menu 10.1. So the default settings "ex factory" are reactivated. This facilitates a later recommissioning.

10 MAINTENANCE

General

The SRD requires no periodical maintenance. When replacing components during repair work, the safety requirements document EX EVE0108 must be observed!

10.1 Supply filter replacement

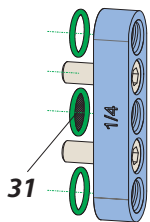

An obstructed supply filter **31** can be replaced. Unscrew the tubes and connection manifold, remove the filter and exchange the filter with a new one.

10.2 Separate upper from lower housing



Attention: This will damage the sealing and after re-assembly the EMV and IP66 protection is no longer guaranteed!



WARNING

To avoid any personal injury resulting from bursting of parts, take off air supply before any removal of electronic board.



Use proper ESD precautions when opening this device for any servicing.

To remove cover from housing, loosen 3 screws **A**. Unscrew knob **15** and remove.

Then loose the 4 screws **B** to separate upper from lower housing.

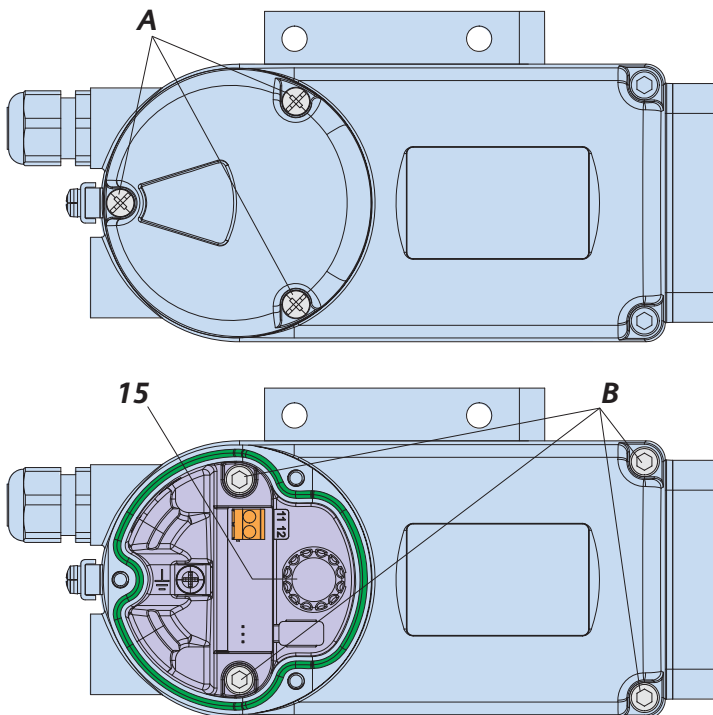

10.3 Removal of the electronic unit

Disconnect the plugs **41** and **42** from the board. Do not use tools to remove plugs, because components could be damaged. Tight-fitting plugs can be easily removed by tilting them diagonally inward before pulling them off. To remove the electronics unit **40**, loosen the 4 screws **C**.

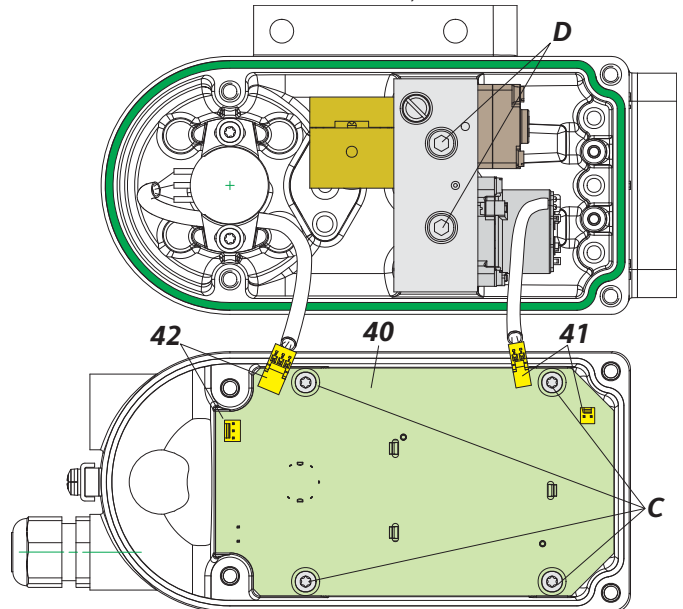

Reassembly of new electronic board in reverse manner.

10.4 Removal of the pneumatic assembly

To replace the fine filter fleece in the pneumatic assembly, it is necessary to remove the pneumatic unit.

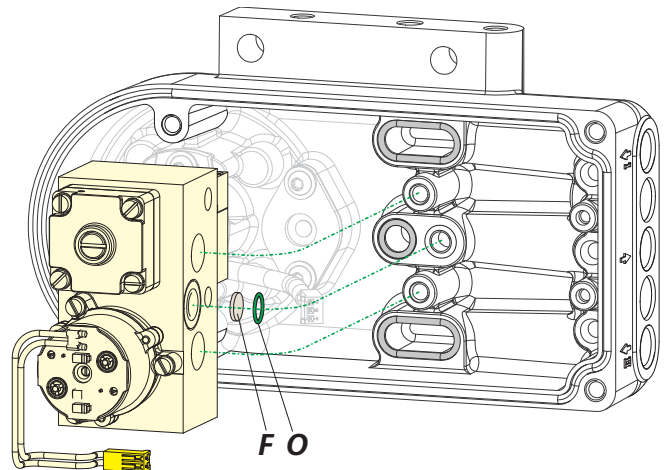

Unscrew the 2 screws **D** and lift up the pneumatic unit. At the bottom is the fine filter fleece **F**, kept by O-Ring **O**. Remove O-Ring carefully by a screwdriver or similar, and replace file filter fleece **F**. Reassembly in reverse order.

Tightening torque for screws **A**: 5 Nm, **B**: 8 Nm, **C**: 2.5 Nm, **D**: 8 Nm

11 TROUBLE-SHOOTING GUIDE

The components of the positioner are under constant surveillance by the installed micro controller. Errors detected are displayed in LCD.

Certain conditions (such as "Stroke limitation active") are displayed in LCD as message.

11.1 Errors detected during initialization

After start-up or reset several initialization phases are passed through which are shown in LCD. If this phase stops an error was detected.

If after renewed Reset ¹⁾ the indicator stops at error code, please contact customer service.

Stating the error code will be of help to the Repair and Service Dept.

(LCD in true text)

	Description
	Micro controller functional test
	Micro controller RAM test
	Micro controller ROM test
	initialize operating system
	initialize monitor
	initialize interfaces
	initialize timer
	initialize EEPROM
	initialize data
	initialize ADC
	initialize communication
	initialize local operation
	start background process
	check options and start
	start operating system

If an error occurs, this will appear on LCD:

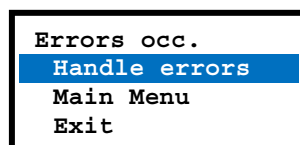

Activate error handler by pressing the Rotary Selector. The error will be displayed; remove error from list by pressing the Rotary Selector. Select Main Menu and go to configuration, or select Exit and go to operation.

11.2 Errors detected during self-test

During cyclical self-test certain components of the SRD are under constant surveillance. At trouble detection in the electronics, output y1 becomes pressureless ('fail safe position'). If after Reset ¹⁾ the display shows the error again the device is probably defective and should be sent to manufacturer for repair.

Symbols in Status line on LCD (acc. NE 107)

Symbol		Possible cause and solution
	Maintenance required	
	Out of specification	
	Check function	
	Failure	

11.3 Diagnosis with LCD inform

If an error occurs, the fault is shown on LCD, with possible cause, and a solution.

Connected to a system with DTM, the remedy is more detailed.

1) Execute by turn off and restart of input signal

12 SAFETY REQUIREMENTS

12.1 EMC and CE

For notes regarding Electromagnetic compatibility EMC and CE labels see Product Specifications Sheet PSS EVE0108 A.

12.2 Explosion protection

(Only if ordered)

Technical data for explosion protection see Product Specifications Sheet PSS EVE0108 and Certificates of Conformity EX EVE0108 A.

For installations located in explosive atmospheres, all relevant national regulations and installation conditions must be observed, e.g. in the Federal Republic of Germany ExeV and DIN VDE 0165.

Attention:

When repairing explosion protected equipment, observe the national regulations.

For repairs use only original parts from the manufacturer! The following applies to the Federal Republic of Germany: Repairs involving parts required for explosion protection must either be carried out by the manufacturer or by authorized personnel and confirmed by certificate.

13 SYSTEM CONFIGURATION

The safety requirements must be observed!

13.1 HART Communication

When using the 'communication' (an alternating current signal, which is modulated onto the 4-20 mA signal), it must be observed that the connected outputs are suitable for the used frequency ranges. Apart from the load, also the alternating current impedances have to be observed. It is recommended therefore, to use only suitable instruments.

To eliminate crosstalk between leads and to reduce disturbances through electromagnetic influences, it is recommended to use twisted paired shielded leads (0.3 to 2.5 mm², max. 100 pF/m).

The capacities of the leads and the connected instruments must not exceed the maximum values for HART.

All components which are connected to the SRD in an explosion hazardous area, require an Ex Approval. The applicable limit values must not be exceeded concerning the maximum defined capacitance C_i , inductance L_i , voltage U_i and current I_i .

Measuring HART Communication Signal

If a reliable communication signal can not be received, it is advisable to check the level with an oscilloscope. The first data block always comes from the configurator and the second block is the reply from the SRD.

HART	measured at configurator:	measured at SRD:
Configurator transmits	at least 350 mVpp	at least 120 mVpp
SRD transmits	at least 120 mVpp	at least 400 mVpp

13.5 System configuration

Electrical connection

Connection compartment see chapter “Electrical connection”

Electrical connection for SRD in intrinsic safe (Ex i) version

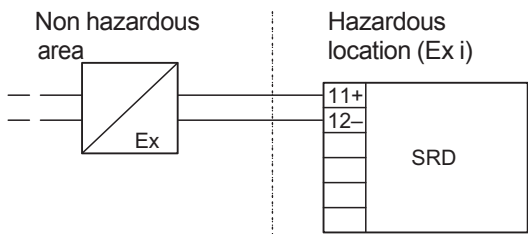

Connection values

HART / 4-20 mA

- Terminals..... 11+ / 12-
- Signal range..... 4 to 20 mA
- Input voltage DC 12 to 36 V (non loaded)

When used in hazardous areas, the max. supply voltages, etc. on nameplate resp. certificate of conformity, have to be observed!

Terminals

	Input					
	11	12				
Input signal / Setpoint value						
HART 4-20 mA	11+	12-				

DIMENSIONS with gauges and manifold

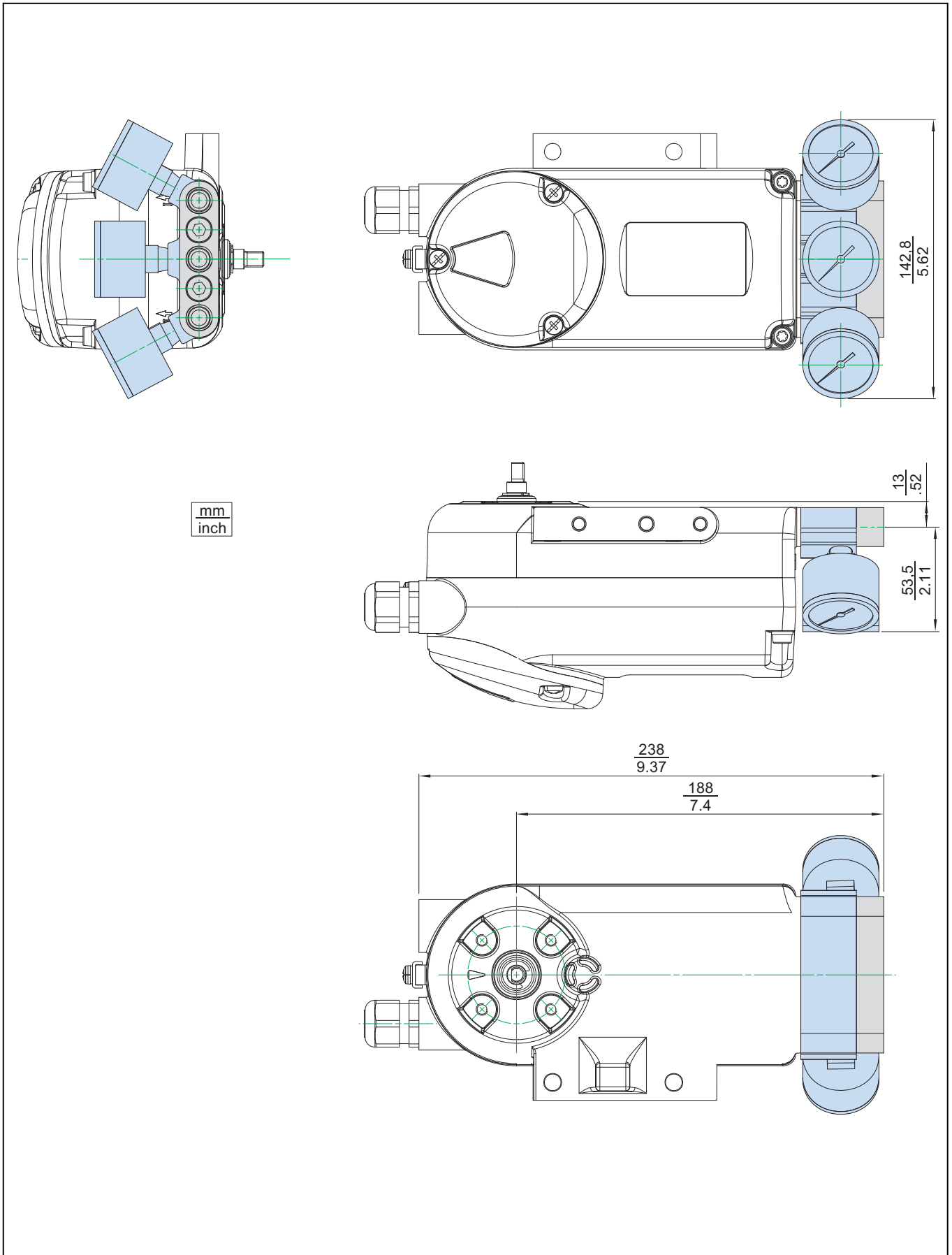



VEREENIGING

Tel: 011 397 2833
Fax: 011 397 4700

DURBAN

Tel: 031 579 2593
Fax: 031 579 2562



E-mail: sales@valve.co.za
Exports: africaexports@valve.co.za

www.valve.co.za



SCAN ME