

LPP-M2-S Metering Pumps

TECHNICAL DATA SHEET



Features

- Only the hose is in contact with the medium
- Self-priming, 95% of full vacuum
- Reversible rotation
- Patented tube leak detector system
- Will never vapour lock or lose prime
- Fully occluded, no backward flow
- No valves – no clogging
- Dry run capability
- Variable speed motor
- Exact flow per revolution or respective of the pipeline pressure
- Accurate metering throughout the whole adjustment range
- Remote start/stop feature
- Automatic identification of motor voltage
- Available with flow verification sensor
- Digital touchpad adjustment – precise and reliable
- Display: VGA backlit LCD, UV resistant
- Display languages: English, German, Spanish, French
- Security: Programmable 4-digit password
- Overcurrent protection with alarm

Technical Data

Weight/Shipping weight	13,9 kg / 15 kg
Maximum Flow	126 l/h
Maximum working pressure	8,6 bar
Maximum suction lift	9 m water, 0,1 bar (Abs)
Maximum viscosity	12 000 centipoise
Motor installed power	0,22 kW
Remote adjustment	4-20mA, 0-10 VDC or pulse
Feedbacks	4-20mA, pulse and 4 alarm contacts
Voltage (max amp)	Automatic identification: 96-264VAC 50/60Hz (2 amp)
Maximum ambient Temp.	-10° to 45° C
Accuracy	+/- 0.5%
Repeatability	+/- 0.5%
Maximum fluid temperature	54° C
Output Speed control range	1-100% in 0.1% increment 0.04-1% in 0.01% increment
Enclosure	IP66
Plug type	250V, AC, CEE7/VII (Europe)

Materials of Construction

Primary pump wetted components:

Pump tube elements	Norprene® (for chemicals) or Tygothane® (for oils and fats) or Tygon lined Norprene® (acids). Adapter fittings: PVDF
--------------------	---

Accessories wetted components:

Suction tubing	Clear PVC
Suction strainer	Natural polypropylene
Discharge tubing	Natural Polyethylene (LLDPE)
Injection fitting with check valve	Body & insert: PVDF

Non-wetted components:

Pump head	Thermoplastic
Housing	Powder coated aluminium
Pump head cover	Clear acrylic, annealed
Cover screws	300 SS, polypropylene caps
Roller assembly	Rotor: Valox® (PBT) Rollers: Nylon Roller bearings: enclosed stainless steel ball bearing
Motor shaft	Chrome plated steel
Leak detector pins	Hastelloy C-276

DIMENSIONS:

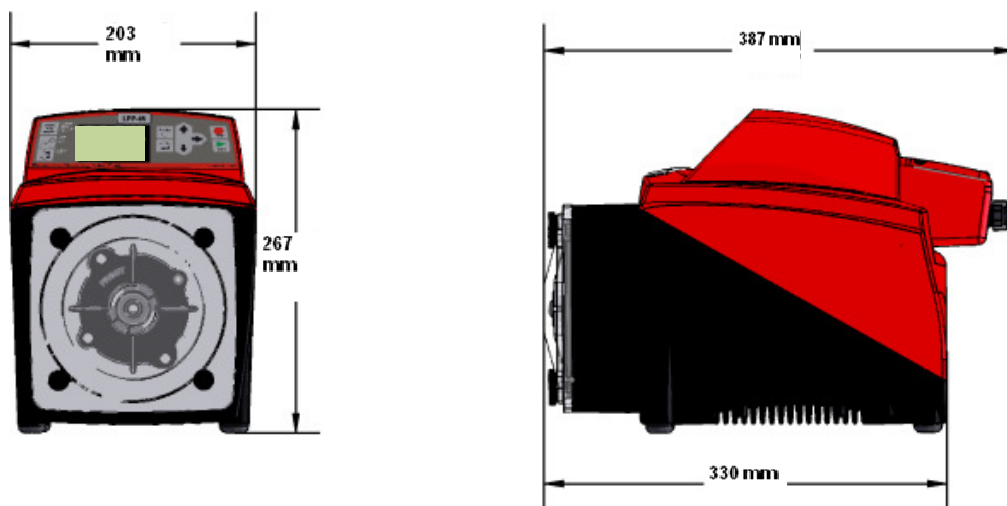

MODEL NUMBER MATRIX:

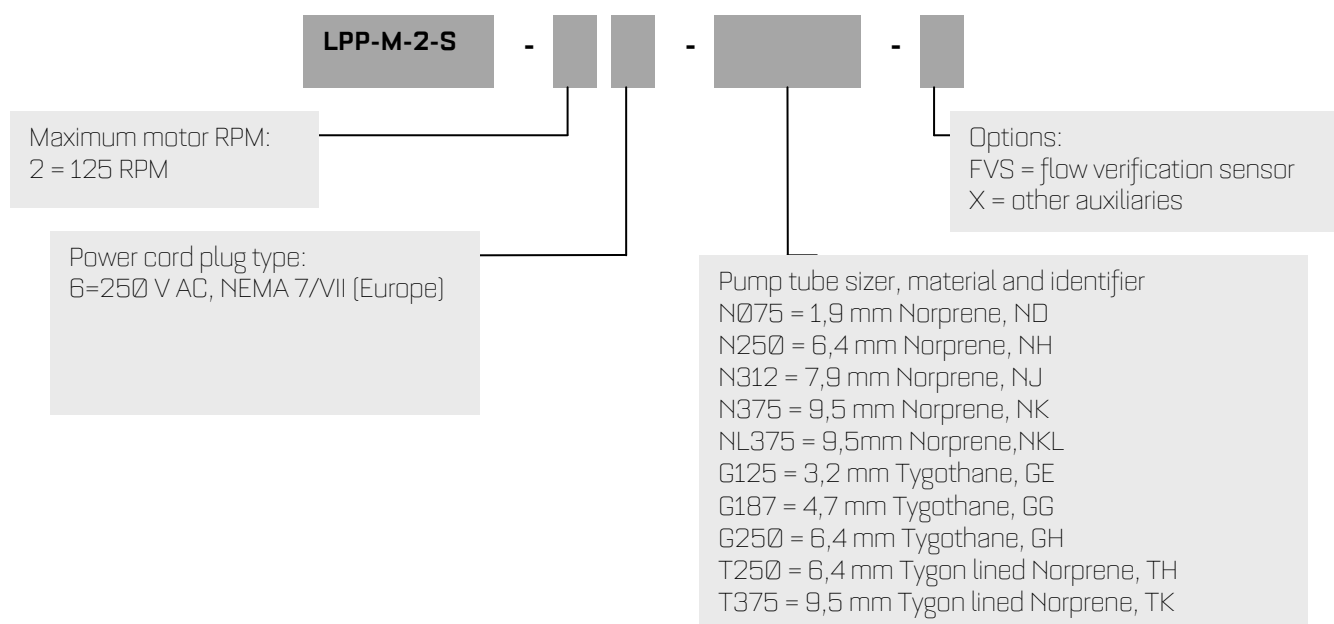

MAXIMUM FLOW RATE AND PRESSURE CAPABILITIES:

Tube number	Tubing material	Bar	Liters per hour
N075	Norprene	8,6	7,8
N250	Norprene	8,6	66
N312	Norprene	8,6	96
N375	Norprene	8,6	126
NL375	Norprene Low Pressure	2	126
G125	Tygothane	4,5	17.4
G187	Tygothane	4,5	38.4
G250	Tygothane	4,5	94.2
T250	Tygon lined Norprene	3,5	55.1
T375	Tygon lined Norprene	3,5	108