

## Toothed belt axes ELGC-TB-KF

**FESTO**



This drive is also available as a product unit as part of the Simplified Motion Series:  
Toothed belt axis ELGS-TB-KF



## Key features

### At a glance



- Optimal installation space to working space ratio
- Protected against external influences by internal guide
- Compact, integrated coupling, easy to service
- Unique assembly system
- Compact double bearing integrated in the axis to save space
- Stainless steel cover strip kept in place with magnetic strips
- Easy to clean and less susceptible to contamination

#### Compact

Optimum dimensions thanks to the integrated compact coupling and a very short slide

#### Flexible

Adapterless combination of ELGC and EGSC using the innovative "one size down" assembly system

#### Integrated

Simple position sensing with proximity switch SMT-8M and integrated positioning magnet

#### Protected

The cover strip and optional vacuum connection protect against particle emissions and atmospheric pollution

### Modular and flexible with motor, motor mounting kit and servo drive

#### Motor

Servo motor



Stepper motor



#### Servo drive

Servo drive



Motor controller for stepper motor



#### Motor mounting kit

Axial kit

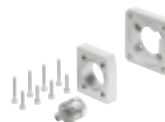

Parallel kit

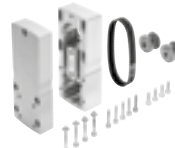

### Simplicity in one unit

This product is also available as a product unit as part of the Simplified Motion Series:



- The Simplified Motion Series combines the simplicity of pneumatics with the benefits of electric automation. The perfect solution for all users who are looking for an electric alternative for very simple movement and positioning tasks, but don't want the commissioning process for traditional electric drive systems that can often be quite complex.
- Simplified functionality for simple movements between two end positions
- A variety of movements with different mechanical systems
- Integrated products eliminate the need for a control cabinet
- Quick and easy commissioning without software or special expertise
- Digital I/O and IO-Link integrated as standard

## Key features

### From individual axis to complete handling system

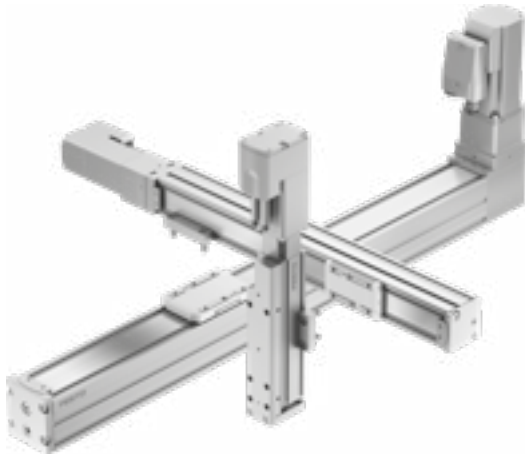

- The toothed belt and spindle axes ELGC and mini slide EGSC form a scalable modular system for compact automation
- The shared platform architecture creates a consistent range with matching interfaces. A large number of systems can be realised entirely without adapter plates
- Powerful drive and guide components ensure a long service life, as well as excellent load capacity and reliability
- The uniform and universal range of accessories reduces warehousing and design costs
- Two position sensing functions can be selected:
  - With magneto-resistive proximity switches (detection via integrated magnets)
  - With inductive proximity switches (detection via switch lug)

### The products for the handling system

Spindle axis  
ELGC-BS



Toothed belt axis  
ELGC-TB



Guide axis  
ELFC



Mini slide  
EGSC



### Typical handling systems

For applications where compact dimensions are essential, the axes ELGC can be combined into very space-saving handling systems that are suitable for assembly systems, test and inspection systems, small parts handling, the electronics industry and desktop applications. The very compact linear axes ELGC, mini slide EGSC and electric cylinder EPCC offer an optimal ratio between installation space and working space. They feature a common system approach and platform architecture and the connections are largely adapterless.

Cantilever system

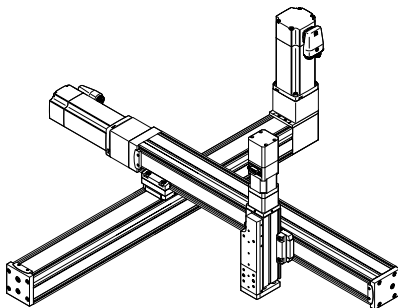

Planar surface gantry

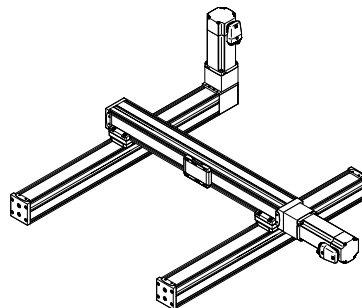

3-dimensional gantry

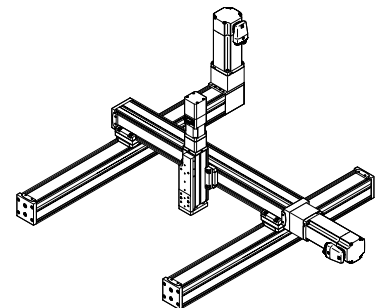

## Key features

**Matrix showing combinations between axis ELGC/ELGS-TB, ELGC/ELGS-BS, mini slide EGSC/EGSS-BS, electric cylinder EPCC/EPCS-BS and guide axis ELFC**  
 Mounting options with profile mounting and via angle kit

	Size	Assembly axis ELGC-BS/-TB; ELFC; EGSC-BS; EPCC-BS; ELGS-BS/-TB; EGSS-BS, EPCS-BS			
		25	32	45	60
Base axis	32	■	–	–	–
ELGC-BS/-TB; ELFC;	45	–	■	–	–
ELGS-BS/-TB	60	–	–	■	–
	80	–	–	–	■

With profile mounting EAHF-L2-...-P-D...

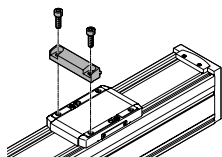

- Mounting option: base axis with one-size-down assembly axis

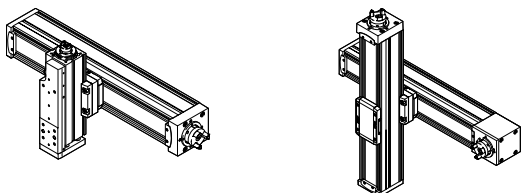

With angle kit EHAA-D-L2-...-AP

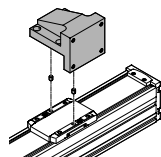

- Mounting option: base axis rotated through 90° with one-size-down assembly axis

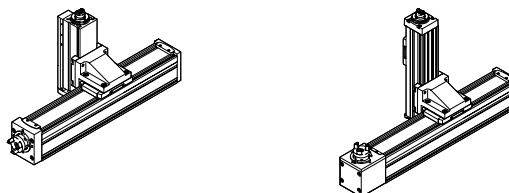

**Matrix showing combinations between axis ELGC/ELGS-TB, ELGC/ELGS-BS, mini slide EGSC/EGSS-BS, electric cylinder EPCC/EPCS-BS and guide axis ELFC**  
 Assembly options with adapter kit or direct mounting

	Size	Assembly axis ELGC-BS/-TB; ELFC; EGSC-BS; EPCC-BS; ELGS-BS/-TB; EGSS-BS, EPCS-BS				
		25	32	45	60	80
Base axis	32	■	–	–	–	–
ELGC-BS/-TB; ELFC;	45	–	■	–	–	–
ELGS-BS/-TB	60	–	–	■	–	–
	80	–	–	–	■	–

	Size	Assembly axis EGSC-BS; EGSS-BS			
		25	32	45	60
Base axis	25	■	–	–	–
EGSC-BS;	32	–	■	–	–
EGSS-BS	45	–	–	■	–
	60	–	–	–	■

With adapter kit EHAA-D-L2

- Mounting option: base axis with the same size assembly axis
- Mounting option: base axis with height adjustment for one-size-down assembly axis
- When motors are mounted using parallel kits, this may lead to interfering contours. In this case, the adapter plate is required for height compensation

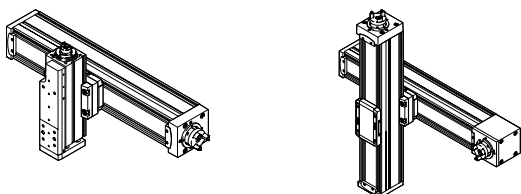
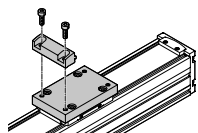

With direct mounting

- Mounting option: base axis with the same size assembly axis

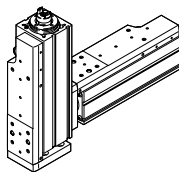

## Type codes

001	Series
ELGC	Gantry axis
002	Drive system
TB	Toothed belt
003	Guide
KF	Recirculating ball bearing guide
004	Size
45	45
60	60
80	80

005	Stroke
200	200
300	300
500	500
600	600
800	800
1000	1000
1200	1200
1500	1500
1800	1800
2000	2000

Peripherals overview

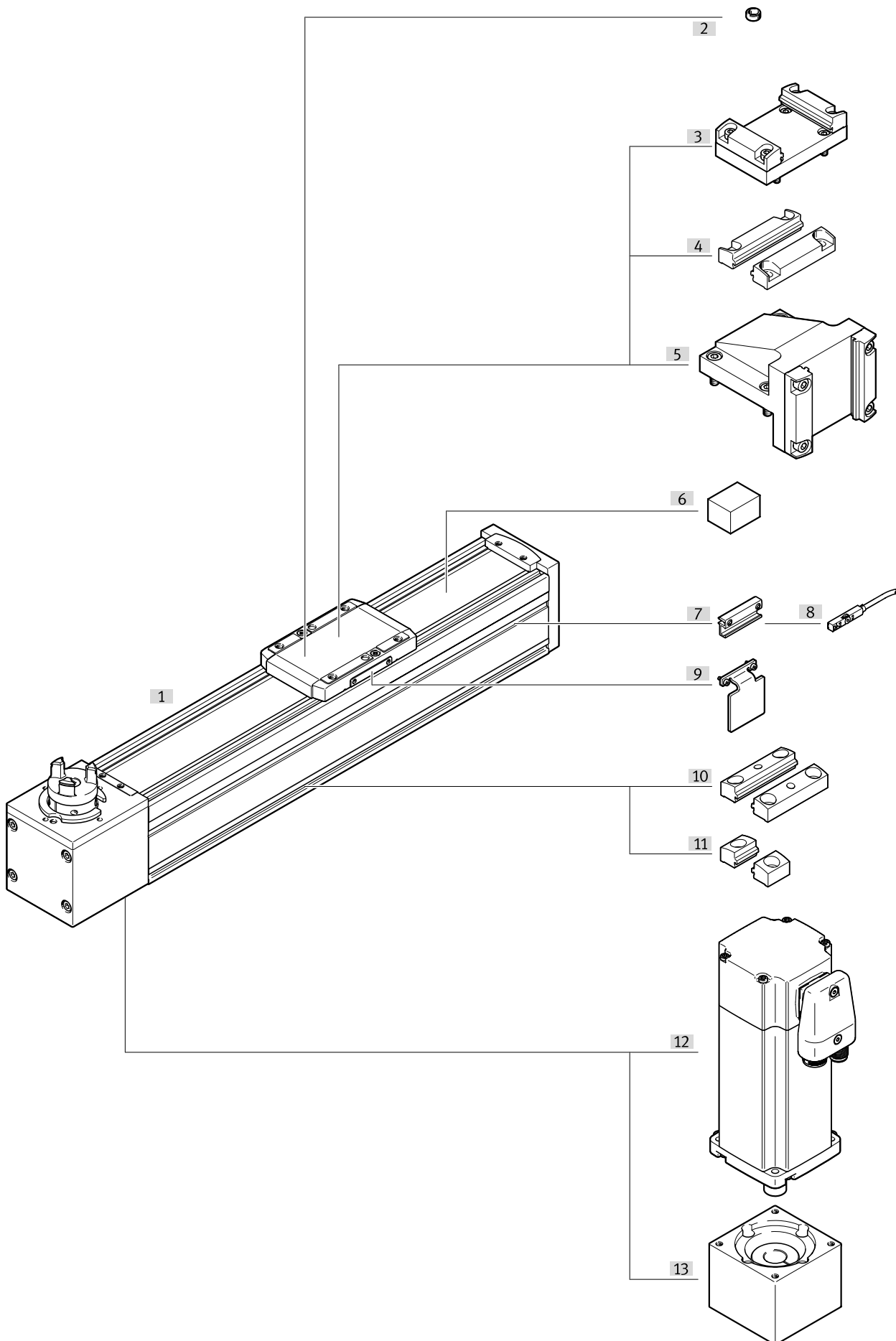

## Peripherals overview

Accessories		
Type	Description	→ Page/Internet
[1] Toothed belt axis ELGC-TB-KF	Electric drive	8
[2] Centring pin/sleeve ZBS/ZBH	For centring loads and attachments on the slide	26
[3] Adapter kit EHAA-D-L2	<ul style="list-style-type: none"> <li>For axis/axis mounting with adapter plate</li> <li>Mounting option: base axis with same size or one-size-down assembly axis (→ page 4)</li> <li>When motors are mounted using parallel kits, this may lead to interfering contours. In this case, the adapter plate is required for height compensation (download CAD data → <a href="http://www.festo.com">www.festo.com</a>)</li> </ul>	23
[4] Profile mounting EAHF-L2-...-P-D...	<ul style="list-style-type: none"> <li>For axis/axis mounting without adapter plate</li> <li>Mounting option: base axis with one-size-down assembly axis (→ page 4)</li> </ul>	22
[5] Angle kit EHAA-D-L2-...-AP	For mounting one-size-down vertical axes (assembly axes) on base axes with mounting position "slide at top" (→ page 4)	24
[6] Clamping element EADT-S-L5-32	Tool for retensioning the cover strip	26
[7] Sensor bracket EAPM-L2-SH	For mounting the proximity switches on the axis. The proximity switches can only be mounted using the sensor bracket	25
[8] Proximity switches SIES-8M	Inductive proximity switches, for T-slot	26
Proximity switches SMT-8M	Magnetic proximity switches, for T-slot	26
[9] Switch lug EAPM-L2-...-SLS	For sensing the slide position in conjunction with inductive proximity sensors SIES-8M	25
[10] Profile mounting EAHF-L2-...-P	For mounting the axis on the side of the profile. The profile mounting can be fixed in place on the mounting surface using the drill hole in the centre	21
[11] Profile mounting EAHF-L2-...-P-S	For mounting the axis on the side of the profile	20
[12] Motor EMME-AS, EMMS-ST	Motors specially matched to the axis	19
[13] Axial kit EAMM-A	For axial motor mounting	19

## Sealing air connection



Air is exchanged between the interior of the cylinder and the environment via a sealing air connection. This prevents negative pressure or excess pressure arising in the interior of the cylinder.

Additional functions of the connection:

- Application of slight negative pressure prevents emission of particles
- Application of slight excess pressure prevents atmospheric pollution

Suitable push-in fittings → page 26

Data sheet

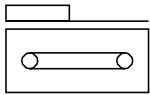

- - Size  
45 ... 80
- - Stroke length  
200 ... 2000 mm
- - [www.festo.com](http://www.festo.com)



General technical data				
Size		45	60	80
Design		Electromechanical axis with toothed belt		
Guide		Recirculating ball bearing guide		
Mounting position		Any		
Working stroke	[mm]	200, 300, 500, 600, 800, 1000, 1200, 1500	200, 300, 500, 600, 800, 1000, 1200, 1500, 1800, 2000	200, 300, 500, 600, 800, 1000, 1200, 1500, 1800, 2000
Max. feed force $F_x$	[N]	75	120	250
Max. no-load torque <sup>1)</sup>	[Nm]	0.075	0.194	0.413
Max. no-load resistance to shifting <sup>1)</sup>	[N]	7.8	15.6	24.7
Max. driving torque	[Nm]	0.716	1.49	4.178
Max. speed	[m/s]	1.2	1.5	1.5
Max. acceleration	[m/s <sup>2</sup> ]	15		
Repetition accuracy	[mm]	±0.1		
Position sensing		Magneto-resistive, inductive		

1) At 0.2 m/s

Operating and environmental conditions		
Ambient temperature <sup>1)</sup>	[°C]	0 ... +50
Degree of protection		IP40
Duty cycle	[%]	100
Maintenance interval		Life-time lubrication

1) Note operating range of proximity switches

Weight [g]				
Size		45	60	80
Basic weight with 0 mm stroke <sup>1)</sup>		760	1775	3500
Additional weight per 10 mm stroke		23	43	73
Moving mass		169	482	901

1) Including slide

Toothed belt				
Size		45	60	80
Indexing	[mm]	2	3	3
Elongation <sup>1)</sup>	[%]	0.187	0.124	0.200
Effective diameter	[mm]	19.1	24.83	33.42
Feed constant	[mm/rev]	60	78	105

1) At max. feed force

## Data sheet

Mass moment of inertia		45	60	80
Size				
$J_0$	[kg mm <sup>2</sup> ]	18.62	88.04	291.2
$J_H$ per metre stroke	[kg mm <sup>2</sup> /m]	2.81	8.51	19.27
$J_L$ per kg payload	[kg mm <sup>2</sup> /kg]	91.19	154.11	279.3

The mass moment of inertia  $J_A$  of the entire axis is calculated as follows:

$$J_A = J_0 + J_H \times \text{working stroke [m]} + J_L \times m_{\text{payload [kg]}}$$

## Homing

Homing can be carried out in two ways:

- Against a fixed stop
- Using a reference switch

The following values must be observed:

Size		45	60	80
Max. impact energy	[J]	$0.5 \times 10^{-3}$	$1 \times 10^{-3}$	$2 \times 10^{-3}$
At max. homing speed	[m/s]	0.01		

## Materials

Sectional view

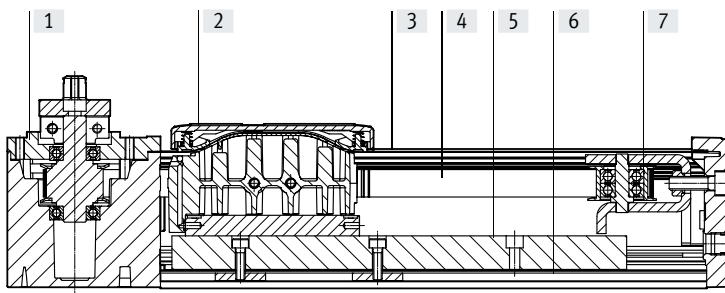

Axis		
[1]	Drive cover	Painted die-cast aluminium
[2]	Slide	Die-cast aluminium
[3]	Cover strip	High-alloy stainless steel
[4]	Toothed belt	Polychloroprene with glass cord and nylon coating
[5]	Guide	Steel
[6]	Profile	Anodised wrought aluminium alloy
[7]	Guide pulley	Aluminium
	Note on materials	RoHS-compliant Contains paint-wetting impairment substances

Data sheet

Characteristic load values

The indicated forces and torques refer to the centre of the guide. The point of application of force is the point where the centre of the guide and the longitudinal centre of the slide intersect. These values must not be exceeded during dynamic operation. Special attention must be paid to the deceleration phase.

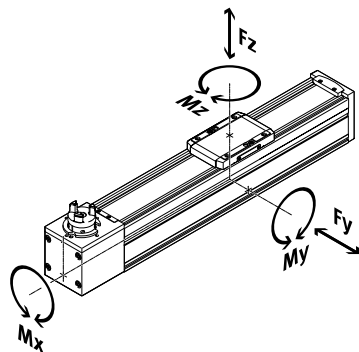

Distance from the slide surface to the centre of the guide

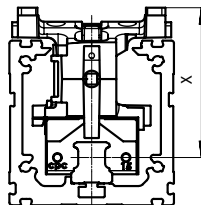

Max. permissible forces and torques on the slide (strength limits)

Size		45	60	80
F <sub>y</sub> max.	[N]	300	600	900
F <sub>z</sub> max.	[N]	600	1800	2700
M <sub>x</sub> max.	[Nm]	5.5	29.1	59.8
M <sub>y</sub> max.	[Nm]	4.7	31.8	56.2
M <sub>z</sub> max.	[Nm]	4.7	31.8	56.2

Distance from the slide surface to the centre of the guide

Size		45	60	80
Dimension x	[mm]	42.8	54.6	72.5

Max. permissible forces and torques for the bearing calculation, for a service life of 5000 km or 5 x 10<sup>6</sup> cycles

Size		45	60	80
F <sub>y</sub> max.	[N]	880	3641	5543
F <sub>z</sub> max.	[N]	880	3641	5543
M <sub>x</sub> max.	[Nm]	5.5	29.1	59.8
M <sub>y</sub> max.	[Nm]	4.7	31.8	56.2
M <sub>z</sub> max.	[Nm]	4.7	31.8	56.2

Note

For a guide system to have a service life of 5000 km, the load comparison factor must have a value of  $f_v \leq 1$ , based on the maximum permissible forces and torques for a service life of 5000 km. This formula can be used to calculate a guide value. The engineering software "PositioningDrives" is available for more precise calculations → [www.festo.com/x/electric-motion-sizing](http://www.festo.com/x/electric-motion-sizing)

If the axis is subjected to two or more of the indicated forces and torques simultaneously, the following equation must be satisfied in addition to the indicated maximum loads:

Calculating the load comparison factor:

$$f_v = \frac{|F_{y1}|}{F_{y2}} + \frac{|F_{z1}|}{F_{z2}} + \frac{|M_{x1}|}{M_{x2}} + \frac{|M_{y1}|}{M_{y2}} + \frac{|M_{z1}|}{M_{z2}} \leq 1$$

F<sub>1</sub>/M<sub>1</sub> = dynamic value  
 F<sub>2</sub>/M<sub>2</sub> = maximum value

## Data sheet

## Calculating the service life

The service life of the guide depends on the load. To be able to make a statement as to the service life of the guide, the graph below plots the load comparison factor  $f_v$  against the service life.

These values are only theoretical. You must consult your local Festo contact for a load comparison factor  $f_v$  greater than 1.

Load comparison factor  $f_v$  as a function of service life  $l$ 

Example:

A user wants to move an  $x$  kg load. Using the formula (→ page 10) gives a value of 1.5 for the load comparison factor  $f_v$ . According to the graph, the guide would have a service life of approx. 1 500 km. Reducing the acceleration reduces the  $M_z$  and  $M_y$  values. A load comparison factor  $f_v$  of 1 now gives a service life of 5000 km.

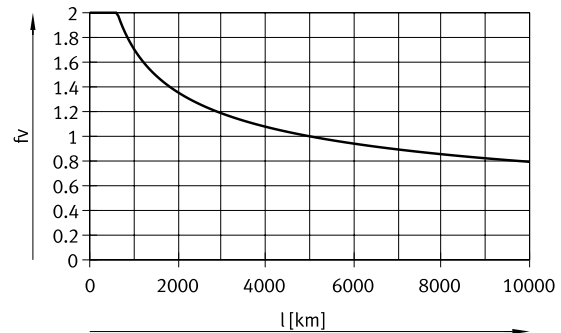

## Comparison of the characteristic load values for 5000 km with dynamic forces and torques of recirculating ball bearing guides

The characteristic load values of the bearing guides are standardised to ISO and JIS using dynamic and static forces and torques. These forces and torques are based on an expected service life of the guide system of 100 km according to ISO or 50 km according to JIS.

As the characteristic load values are dependent on the service life, the maximum permissible forces and torques for a 5000 km service life cannot be compared with the dynamic forces and torques of bearing guides to ISO/JIS.

To make it easier to compare the guide capacity of linear axes ELGC with bearing guides, the table below lists the theoretically permissible forces and torques for a calculated service life of 100 km. This corresponds to the dynamic forces and torques to ISO.

These 100 km values have been calculated mathematically and are only to be used for comparing with dynamic forces and torques to ISO. The drives must not be loaded with these characteristic values as this could damage the axes.

## Max. permissible forces and torques for a theoretical service life of 100 km (from a guide perspective only)

Size		45	60	80
$F_{y_{max}}$	[N]	3240	13400	20400
$F_{z_{max}}$	[N]	3240	13400	20400
$M_{x_{max}}$	[Nm]	20	107	220
$M_{y_{max}}$	[Nm]	17	117	207
$M_{z_{max}}$	[Nm]	17	117	207

## Data sheet

### Feed force F as a function of input torque M

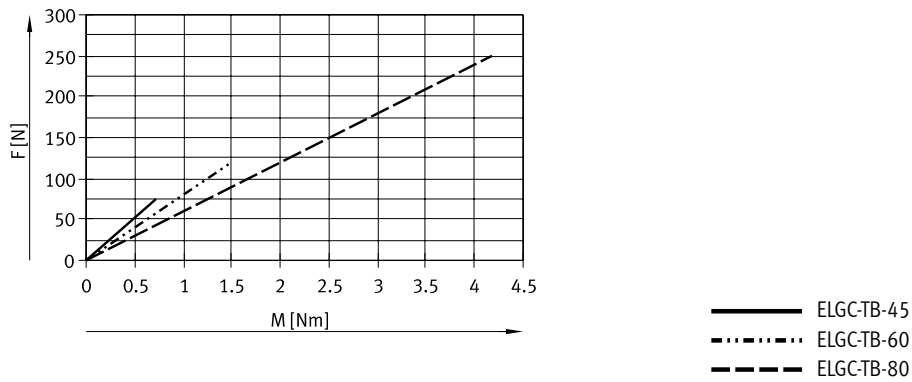

### Second moment of area

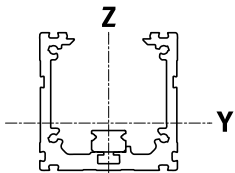

Size		45	60	80
$I_y$	[mm <sup>4</sup> ]	$140 \times 10^3$	$441 \times 10^3$	$1.37 \times 10^6$
$I_z$	[mm <sup>4</sup> ]	$170 \times 10^3$	$542 \times 10^3$	$1.66 \times 10^6$

## Data sheet

### Maximum permissible support spacing $L$ (without profile mounting) as a function of force $F$

In order to limit deflection in the case of large strokes, the axis may need to be supported.

The following graphs can be used to determine the maximum permissible support spacing  $l$  as a function of force  $F$  acting on the axis.

The deflection is  $f = 0.5$  mm.

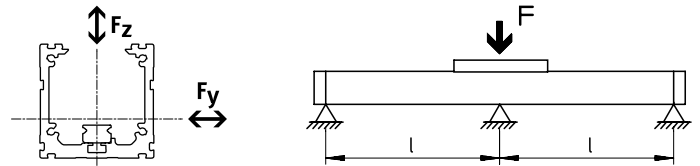

Force  $F_y$   
Size 45

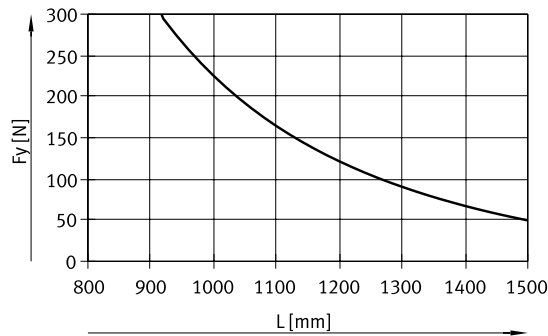

Size 60/80

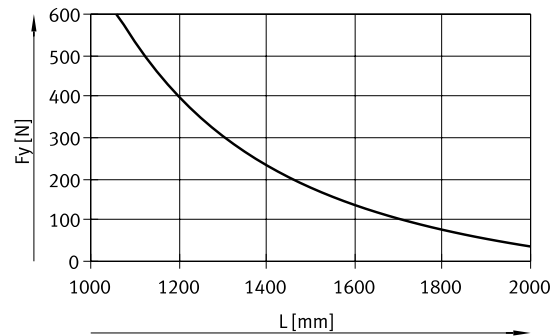

Force  $F_z$   
Size 45

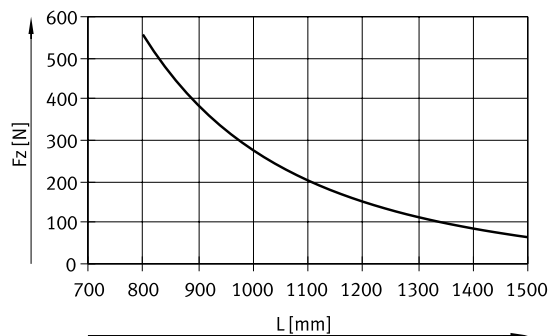

Size 60/80

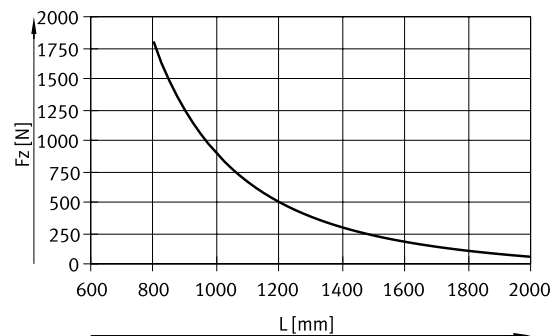

- ELGC-TB-45
- · - · - · ELGC-TB-60
- - - - - ELGC-TB-80

### Recommended deflection limits

Adherence to the following deflection limits is recommended so as not to impair the functionality of the axes. Greater deformation can result in increased friction, greater wear and reduced service life.

Size	Dynamic deflection (moving load)	Static deflection (stationary load)
45 ... 80	0.05% of the axis length, max. 0.5 mm	0.1% of the axis length

Data sheet

Dimensions

Download CAD data → [www.festo.com](http://www.festo.com)

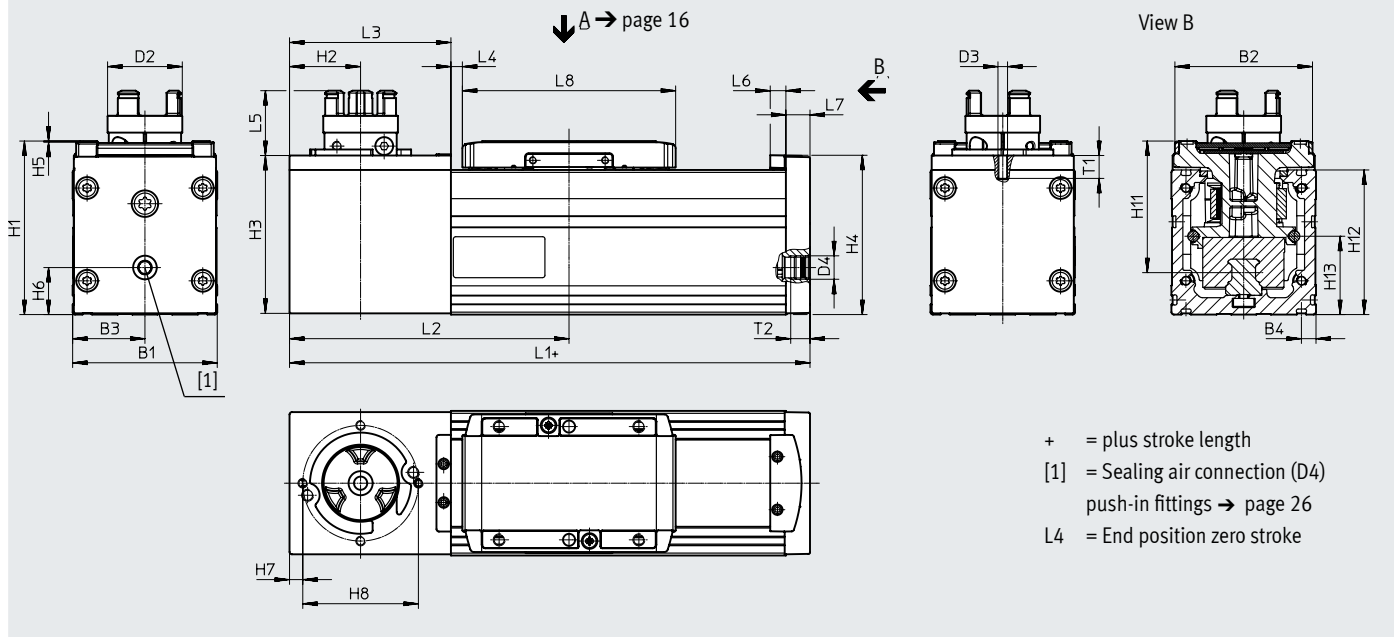

Size	B1	B2	B3	B4	D2 <sup>1)</sup> ∅	D3	D4	H1	H2
45	45	42.6	22.5	6.1	16.3	–	G1/8	54	22
60	60	57.1	30	6.1	31.4	M4	G1/8	72	29.5
80	80	77.1	40	6.1	31.4	M6	G1/8	96	39.5

Size	H3	H4	H5	H6	H7	H8	H11	H12	H13
45	49	49.6	0.5	12.5	–	–	42.8	45	18.5
60	65.5	66.1	0.5	19.5	5.5	48	54.6	60	32.5
80	85.5	88.1	0.5	20	7	65	72.5	80	41.5

Size	L1	L2	L3	L4 <sup>2)</sup> min.	L5	L6	L7	L8	T1	T2
45	165	90	52	4.25	19.9	6.5	7	67.5	–	8
60	216	116	67	4.75	26.9	6.5	10	88.5	9.5	8
80	260	145	87	5	25.9	6.5	12	106	12.5	8

1) Coupling diameter or interference diameter of locking screw  
 2) Includes a stroke reserve of approx. 3 mm

## Data sheet

## Dimensions

Download CAD data → [www.festo.com](http://www.festo.com)

## Profile

## Size 45

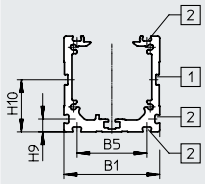

## Size 60

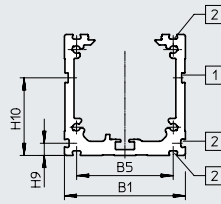

## Size 80

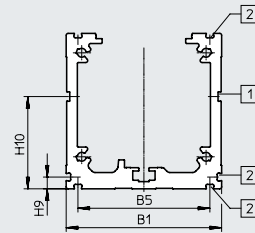

[1] Slot for sensor bracket

[2] = Mounting slot

Size	B1	B5	H9	H10
45	45	32,9	6,1	24,5
60	60	47,9	6,1	38,5
80	80	67,9	6,1	47,5

Data sheet

Dimensions

Download CAD data → [www.festo.com](http://www.festo.com)

Slide  
Size 45

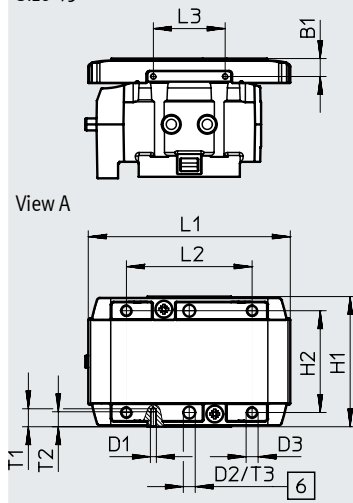

Size 60

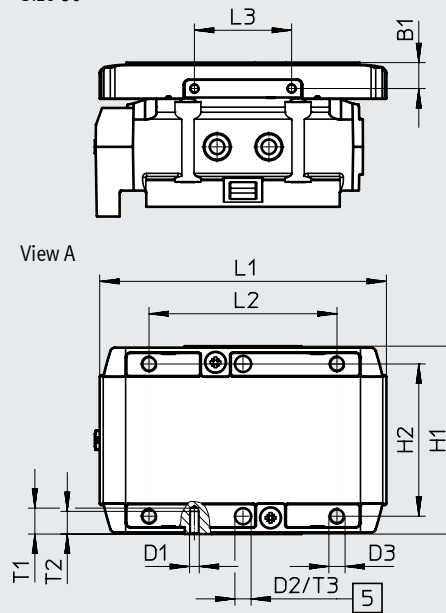

- [5] Drill hole for centring sleeve ZBH
- [6] Drill hole for centring pin ZBS

Size	B1 ±0.1	D1	D2 ∅ H8	D3	H1 ±0.1	H2 ±0.1 For D2 ±0.03
45	6	M2	4	M4	43.5	34
60	8	M3	5	M5	58	47

Size	L1	L2 ±0.1	L3 ±0.1	T1	T2	T3 +0.1	T4 <sup>1)</sup>
45	67.5	42	24	6	5	3.1	6 ... 7.5
60	88.5	58	30	9	7	1.3	8.5 ... 10

1) Recommended screw-in depth

## Data sheet

## Dimensions

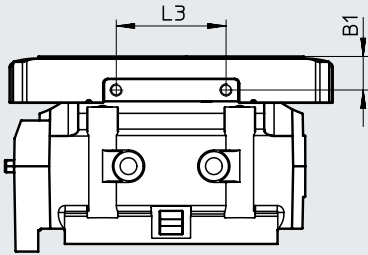
Download CAD data → [www.festo.com](http://www.festo.com)Slide  
Size 80

View A

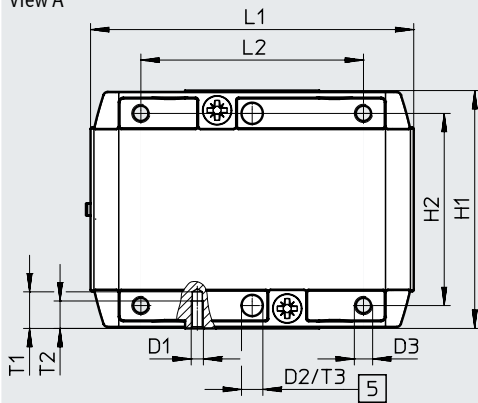

[5] Drill hole for centring sleeve ZBH

Size	B1	D1	D2 ∅ H8	D3	H1	H2 ±0.1 For D2 ±0.03
80	±0.1 11	M4	7	M6	±0.1 78	63

Size	L1	L2 ±0.1	L3 ±0.1	T1	T2	T3 +0.1	T4 <sup>1)</sup>
80	106	73	36	12	9	1.6	11 ... 14

1) Recommended screw-in depth

## Data sheet

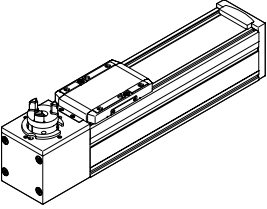
Ordering data	Size	Stroke [mm]	Part no.	Type
	45	200	<b>8062768</b>	ELGC-TB-KF-45-200
		300	<b>8062769</b>	ELGC-TB-KF-45-300
		500	<b>8062770</b>	ELGC-TB-KF-45-500
		600	<b>8062771</b>	ELGC-TB-KF-45-600
		800	<b>8062772</b>	ELGC-TB-KF-45-800
		1000	<b>8062773</b>	ELGC-TB-KF-45-1000
		1200	<b>8062774</b>	ELGC-TB-KF-45-1200
		1500	<b>8062775</b>	ELGC-TB-KF-45-1500
	60	200	<b>8062776</b>	ELGC-TB-KF-60-200
		300	<b>8062777</b>	ELGC-TB-KF-60-300
		500	<b>8062778</b>	ELGC-TB-KF-60-500
		600	<b>8062779</b>	ELGC-TB-KF-60-600
		800	<b>8062780</b>	ELGC-TB-KF-60-800
		1000	<b>8062781</b>	ELGC-TB-KF-60-1000
		1200	<b>8062782</b>	ELGC-TB-KF-60-1200
		1500	<b>8062783</b>	ELGC-TB-KF-60-1500
		1800	<b>8062784</b>	ELGC-TB-KF-60-1800
		2000	<b>8062785</b>	ELGC-TB-KF-60-2000
	80	200	<b>8062786</b>	ELGC-TB-KF-80-200
		300	<b>8062787</b>	ELGC-TB-KF-80-300
		500	<b>8062788</b>	ELGC-TB-KF-80-500
		600	<b>8062789</b>	ELGC-TB-KF-80-600
		800	<b>8062790</b>	ELGC-TB-KF-80-800
		1000	<b>8062791</b>	ELGC-TB-KF-80-1000
		1200	<b>8062792</b>	ELGC-TB-KF-80-1200
		1500	<b>8062793</b>	ELGC-TB-KF-80-1500
		1800	<b>8062794</b>	ELGC-TB-KF-80-1800
2000		<b>8062795</b>	ELGC-TB-KF-80-2000	

## Accessories

-  - Note

Depending on the combination of motor and drive, it may not be possible to reach the maximum feed force of the drive.

## Permissible axis/motor combinations with axial kit

Data sheets → Internet: eamm-a

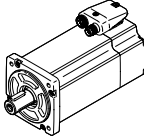
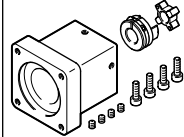
Motor <sup>1)</sup>	Axial kit	
		• Kits for third-party motors → Internet: eamm-a
Type	Part no.	Type
<b>ELGC-TB-KF-45</b>		
With servo motor		
EMME-AS-40-...	4595742	EAMM-A-V32-40P
EMMT-AS-60-...	4608750	EAMM-A-V32-60P
EMME-AS-60-...	4608750	EAMM-A-V32-60P
With stepper motor		
EMMS-ST-42-...	4281142	EAMM-A-V32-42A
EMMS-ST-57-...	4597016	EAMM-A-V32-57A
<b>ELGC-TB-KF-60</b>		
With servo motor		
EMMT-AS-60-...	4133487	EAMM-A-T42-60P
EMME-AS-60-...	4133487	EAMM-A-T42-60P
EMMT-AS-80-...	4623788	EAMM-A-T42-80P
EMME-AS-80-...	4623788	EAMM-A-T42-80P
With stepper motor		
EMMS-ST-57-...	4327034	EAMM-A-T42-57A
EMMS-ST-87-...	4610008	EAMM-A-T42-87A
<b>ELGC-TB-KF-80</b>		
With servo motor		
EMMT-AS-60-...	4824833	EAMM-A-T46-60P
EMME-AS-60-...	4824833	EAMM-A-T46-60P
EMMT-AS-80-...	4624170	EAMM-A-T46-80P
EMME-AS-80-...	4624170	EAMM-A-T46-80P
EMMT-AS-100-...	4624227	EAMM-A-T46-100A
EMME-AS-100-...	4624227	EAMM-A-T46-100A
With stepper motor		
EMMS-ST-87-...	4048771	EAMM-A-T46-87A

1) The input torque must not exceed the max. permissible transferable torque of the axial kit.

## Accessories

### Profile mounting EAHF-L2-...-P-S

Material:

Anodised wrought aluminium alloy

RoHS-compliant

- For mounting the axis on the side of the profile

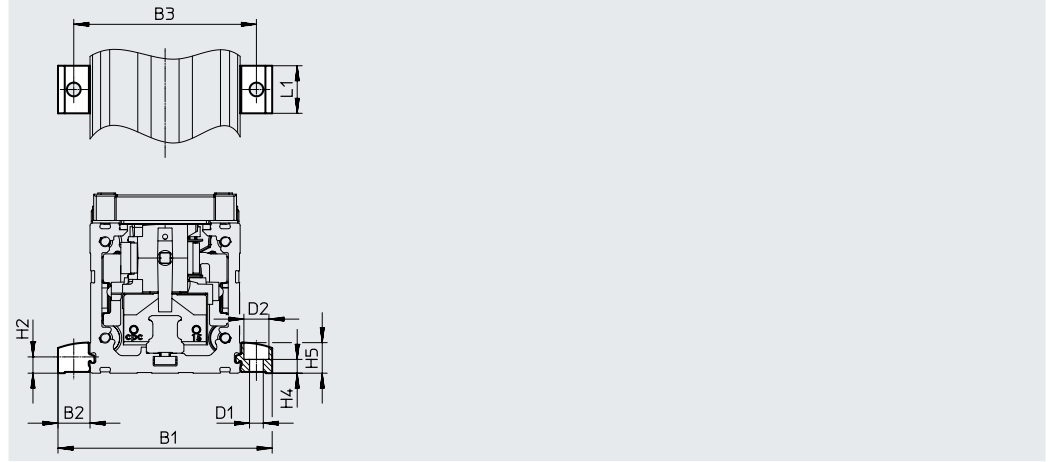
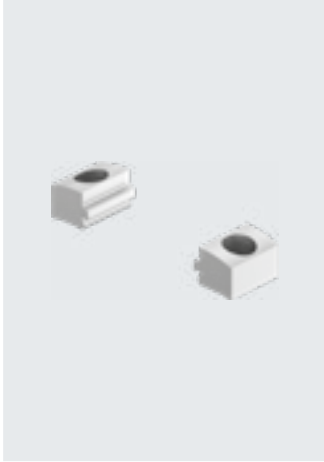

#### Dimensions and ordering data

For size	B1	B2	B3	D1 ∅ H13	D2 ∅ H13	H2
45	70.6	12.8	58	5.5	10	6.1
60	85.6	12.8	73	5.5	10	6.1
80	105.6	12.8	93	5.5	10	6.1

For size	H4 ±0.1	H5	L1	Weight [g]	Part no.	Type
45	5.5	12.2	19	6	5184133	EAHF-L2-45-P-S
60	5.5	12.2	19	6	5184133	EAHF-L2-45-P-S
80	5.5	12.2	19	6	5184133	EAHF-L2-45-P-S

## Accessories

### Profile mounting EAHF-L2-...-P

Material:

Anodised wrought aluminium alloy

RoHS-compliant

- For mounting the axis on the side of the profile.

The profile mounting can be attached to the mounting surface using the drill hole in the centre.

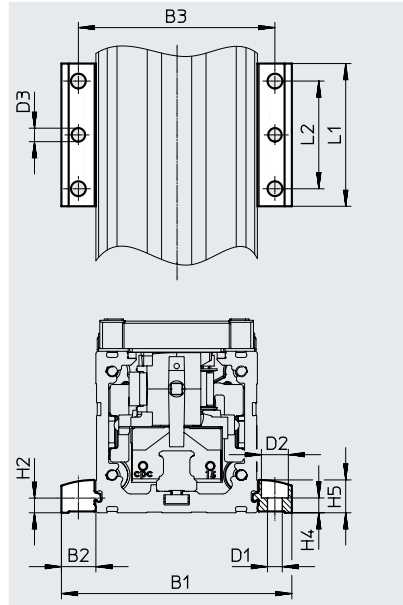

#### Dimensions and ordering data

For size	B1	B2	B3	D1 ∅ H13	D2 ∅ H13	D3 ∅	H2
45	70.6	12.8	58	5.5	10	5	6.1
60	85.6	12.8	73	5.5	10	5	6.1
80	105.6	12.8	93	5.5	10	5	6.1

For size	H4 ±0.1	H5	L1	L2	Weight [g]	Part no.	Type
45	5.5	12.2	53	40	35	4835728	EAHF-L2-45-P
60	5.5	12.2	53	40	35	4835728	EAHF-L2-45-P
80	5.5	12.2	53	40	35	4835728	EAHF-L2-45-P

## Accessories

### Profile mounting EAHF-L2-...-P-D...

Material:

Anodised wrought aluminium alloy

RoHS-compliant

- For axis/axis mounting without adapter plate
- Mounting option: base axis with one-size-down assembly axis (→ page 4)

#### Combination matrix

	Size	[2] Assembly axis ELGC-BS/-TB; ELFC; EGSC-BS		
		32	45	60
[1] Base axis ELGC-BS/-TB, ELFC	45	4759748	-	-
	60	-	4759739	-
	80	-	-	4759726

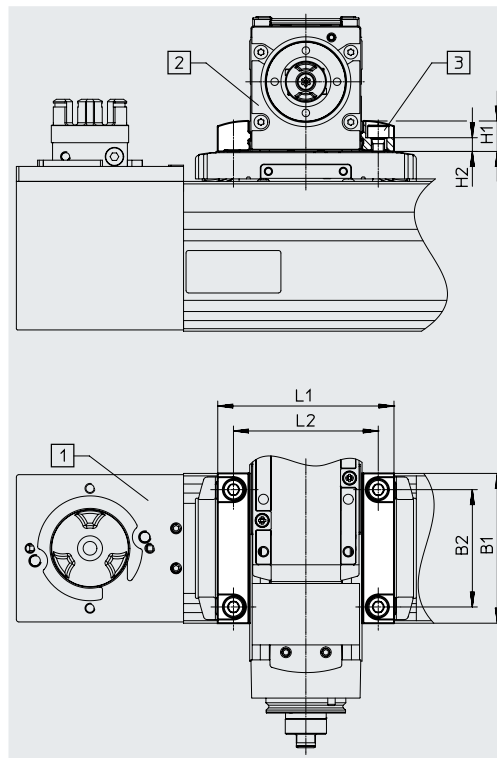

- [1] Base axis  
[2] Assembly axis

#### Dimensions and ordering data

For combination (size)	B1	B2	D1	H1
4 5/32	45	34	M4	9
6 0/45	60	47	M5	12.2
8 0/60	78	63	M6	12.2

For combination (size)	H2 ±0.1	L1	L2	Weight [g]	Part no.	Type
4 5/32	3.7	51.4	42	24	4759748	EAHF-L2-25-P-D2
6 0/45	5.5	70.6	58	56	4759739	EAHF-L2-45-P-D3
8 0/60	4.5	85.6	73	77	4759726	EAHF-L2-45-P-D4

## Accessories

### Adapter kit EHAA-D-L2

Material:

Anodised wrought aluminium alloy

RoHS-compliant

- For axis/axis mounting with adapter plate
- Mounting option: base axis with same size or one-size-down assembly axis (→ page 4)
- When motors are mounted using parallel kits, this may lead to interfering contours. In this case, the adapter plate is required for height compensation (download CAD data → [www.festo.com](http://www.festo.com))

Combination matrix		[2] Assembly axis ELGC-BS-/TB; ELFC; EGSC-BS			
	Size	32	45	60	80
[1] Base axis ELGC-BS-/TB; ELFC	45	8066714	-	-	-
	60	-	8066715	-	-
	80	-	-	8066716	-

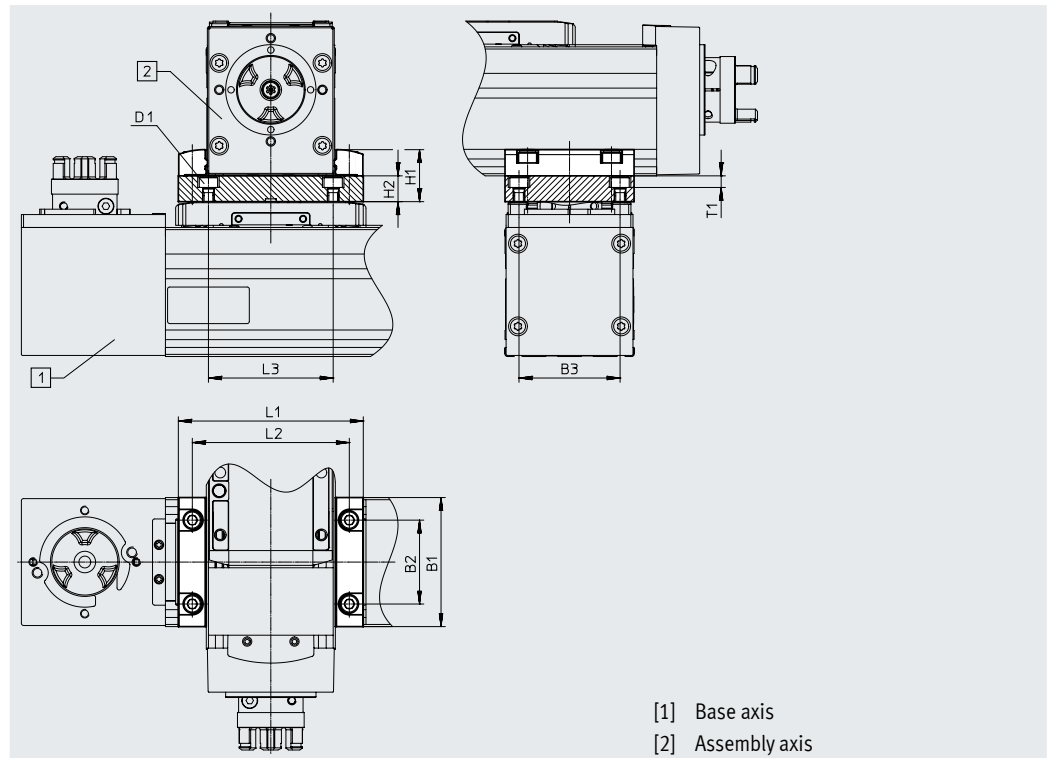
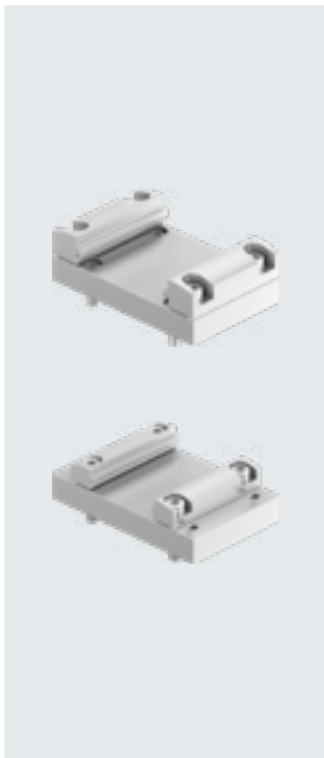

[1] Base axis  
[2] Assembly axis

Dimensions and ordering data												
For combination (size)	B1	B3 ±0.05	D1	H1	H2	L1	L2	L3	T1	Weight [g]	Part no.	Type
4 5/32	45	34	M4	19	10	51.4	42	42	5.4	136	8066714	EHAA-D-L2-45-L2-45
6 0/45	60	47	M5	24.2	12	70.6	58	58	5.4	205	8066715	EHAA-D-L2-60-L2-60
8 0/60	78	63	M6	24.2	12	85.6	73	73	6.4	315	8066716	EHAA-D-L2-80-L2-80

For combination (size)	B1	B2	B3 ±0.05	D1	H1	H2	L1	L2	L3	T1	Weight [g]	Part no.	Type
4 5/45	45	32	34	M4	22.2	10	71	58	42	5.4	136	8066714	EHAA-D-L2-45-L2-45
6 0/60	60	39	47	M5	24.2	12	86	73	58	5.4	205	8066715	EHAA-D-L2-60-L2-60
8 0/80	78	63	63	M6	24.2	12	106	93	73	6.4	315	8066716	EHAA-D-L2-80-L2-80

## Accessories

### Angle kit EHAA-D-L2-...-AP

Material:

Anodised wrought aluminium alloy

RoHS-compliant

- For mounting one-size-down vertical axes (assembly axes) on base axes with mounting position "slide at top" (→ page 4)

#### Combination matrix

[1] Base axis ELGC-BS/-TB; ELFC	Size	[2] Assembly axis ELGC-BS/-TB; ELFC; EGSC-BS		
		32	45	60
45	8066718	-	-	-
60	-	8066719	-	-
80	-	-	-	8066720

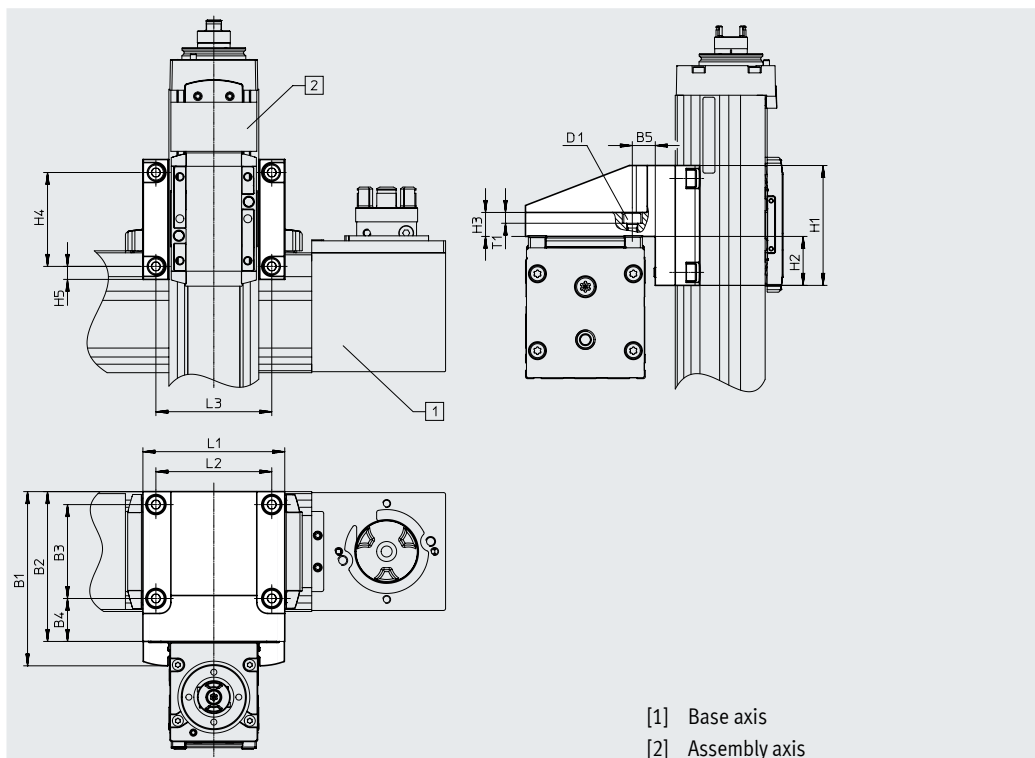

#### Dimensions and ordering data

For combination (size)	B1	B2	B3	B4	B5	D1	H1	H2	H3	H4
4 5/32	69	60	34	20.5	11.5	M4	45	17.5	10	34
6 0/45	87.2	75	47	21.5	21.5	M5	60	24.5	12	47
8 0/60	107.2	95	63	23.5	23.5	M6	78	33.5	12	63

For combination (size)	H5	L1	L2	L3	T1	Weight [g]	Part no.	Type
4 5/32	5.5	52	42	42	5.4	222	8066718	EHAA-D-L2-45-L2-32-AP
6 0/45	6.5	71	58	58	5.4	433	8066719	EHAA-D-L2-60-L2-45-AP
8 0/60	7.5	86	73	73	6.4	768	8066720	EHAA-D-L2-80-L2-60-AP

## Accessories

### Switch lug EAPM-L2-SLS

For sensing using inductive proximity switches SIES-8M

Material:

Galvanised steel  
RoHS-compliant

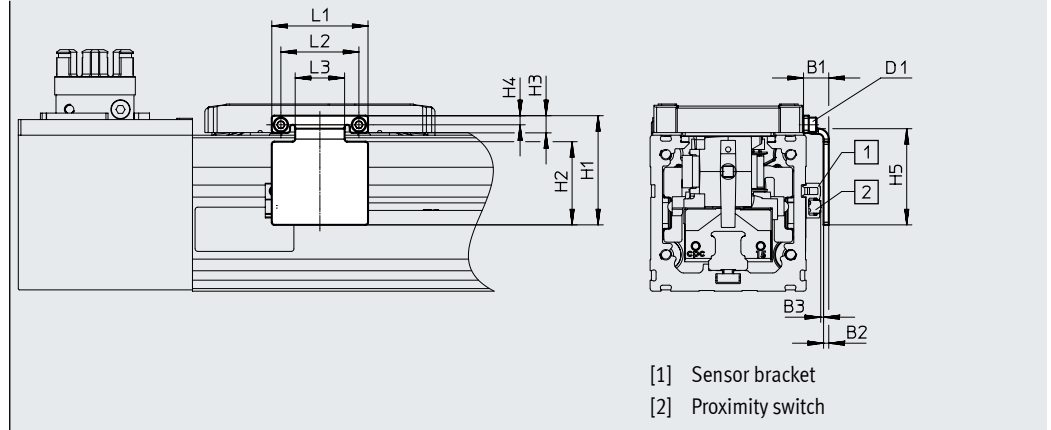
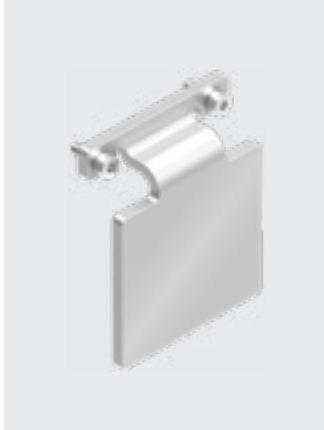

[1] Sensor bracket  
[2] Proximity switch

#### Dimensions and ordering data

For size	B1	B2	B3	D1	H1 ±0.2	H2	H3	H4
45	9.4	2	1.2±0.31	M2	37	28	5.5	3.3
60	9.7	2	1.3±0.31	M3	42	32	6.6	3.5
80	9.5	2	1.1±0.32	M4	53.5	42	8.3	4.5

For size	H5 ±0.2	L1 ±0.2	L2 ±0.15	L3	Weight [g]	Part no.	Type
45	33	30	24	14	18	8067260	EAPM-L2-45-SLS
60	37	37	30	19	27	8067261	EAPM-L2-60-SLS
80	47	44.6	36	23.4	42	8067262	EAPM-L2-80-SLS

### Sensor bracket EAPM-L2-SH

Material:

Anodised wrought aluminium alloy  
RoHS-compliant

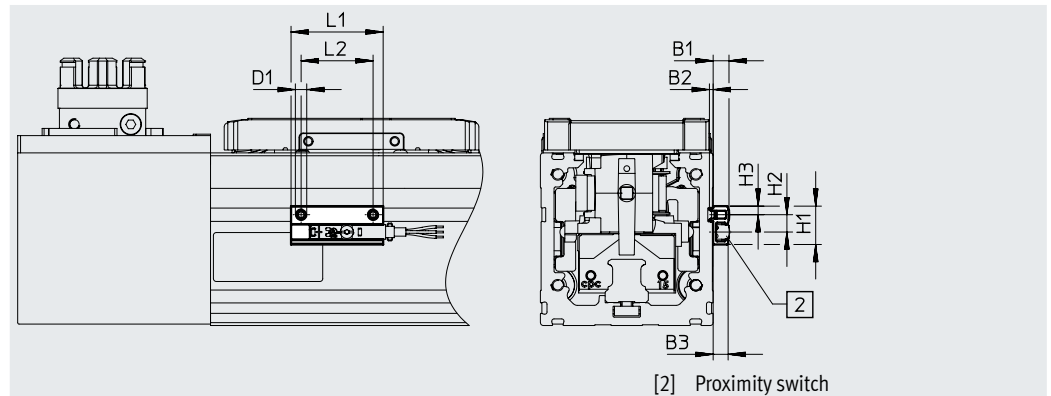
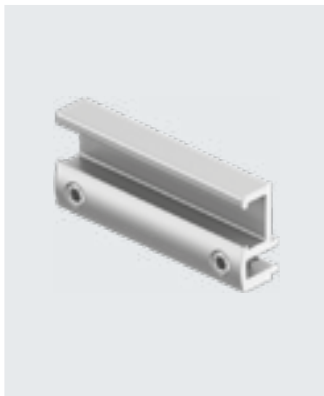



[2] Proximity switch

#### Dimensions and ordering data

For size	B1	B2	D1	H1	H2
45, 60, 80	5.5	1.3	M4	13.4	6

For size	H3	L1	L2	Weight [g]	Part no.	Type
45, 60, 80	3	32	25	4	4759852	EAPM-L2-SH



## Accessories

Ordering data		For size	Description	Part no.	Type	PU <sup>1)</sup>
<b>Centring pin ZBS/centring sleeve ZBH</b>						
	45	For slide		<b>562959</b>	<b>ZBS-4</b>	10
	60			<b>189652</b>	<b>ZBH-5</b>	
	80			<b>186717</b>	<b>ZBH-7</b>	
<b>Clamping element EADT</b>						
	45	Tool for retensioning the cover strip		<b>8065818</b>	<b>EADT-S-L5-32</b>	1
	60, 80			<b>8058451</b>	<b>EADT-S-L5-70</b>	
<b>Push-in fitting</b>						
	45, 60, 80	For sealing air connection		<b>186266</b>	<b>QSM-G1/8-4-I</b>	10
				<b>186267</b>	<b>QSM-G1/8-6-I</b>	

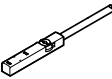
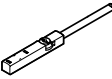
1) Packaging unit

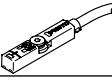
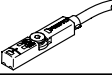
Ordering data – Proximity switches for T-slot, inductive						Data sheets → Internet: sies
	Type of mounting	Switching output	Electrical connection	Cable length [m]	Part no.	Type
<b>N/O contact</b>						
	Inserted in the slot from above, flush with the cylinder profile	PNP	Cable, 3-wire	7.5	<b>551386</b>	<b>SIES-8M-PS-24V-K-7,5-OE</b>
			Plug M8x1, 3-pin	0.3	<b>551387</b>	<b>SIES-8M-PS-24V-K-0,3-M8D</b>
		NPN	Cable, 3-wire	7.5	<b>551396</b>	<b>SIES-8M-NS-24V-K-7,5-OE</b>
			Plug M8x1, 3-pin	0.3	<b>551397</b>	<b>SIES-8M-NS-24V-K-0,3-M8D</b>
<b>N/C contact</b>						
	Inserted in the slot from above, flush with the cylinder profile	PNP	Cable, 3-wire	7.5	<b>551391</b>	<b>SIES-8M-PO-24V-K-7,5-OE</b>
			Plug M8x1, 3-pin	0.3	<b>551392</b>	<b>SIES-8M-PO-24V-K-0,3-M8D</b>
		NPN	Cable, 3-wire	7.5	<b>551401</b>	<b>SIES-8M-NO-24V-K-7,5-OE</b>
			Plug M8x1, 3-pin	0.3	<b>551402</b>	<b>SIES-8M-NO-24V-K-0,3-M8D</b>

Ordering data – Proximity switches for T-slot, magneto-resistive						Data sheets → Internet: smt
	Type of mounting	Switching output	Electrical connection	Cable length [m]	Part no.	Type
<b>N/O contact</b>						
	Insertable in the slot from above, flush with the cylinder profile, short design	PNP	Cable, 3-wire	2.5	<b>574335</b>	<b>SMT-8M-A-PS-24V-E-2,5-OE</b>
			Plug M8x1, 3-pin	0.3	<b>574334</b>	<b>SMT-8M-A-PS-24V-E-0,3-M8D</b>
<b>N/C contact</b>						
	Insertable in the slot from above, flush with the cylinder profile, short design	PNP	Cable, 3-wire	7.5	<b>574340</b>	<b>SMT-8M-A-PO-24V-E-7,5-OE</b>

Ordering data – Connecting cables						Data sheets → Internet: nebu
	Electrical connection, left	Electrical connection, right	Cable length [m]	Part no.	Type	
	Straight socket, M8x1, 3-pin	Cable, open end, 3-wire	2.5	<b>541333</b>	<b>NEBU-M8G3-K-2.5-LE3</b>	
			5	<b>541334</b>	<b>NEBU-M8G3-K-5-LE3</b>	
	Angled socket, M8x1, 3-pin	Cable, open end, 3-wire	2.5	<b>541338</b>	<b>NEBU-M8W3-K-2.5-LE3</b>	
			5	<b>541341</b>	<b>NEBU-M8W3-K-5-LE3</b>	