

**Bray**®

RESILIENT SEATED BUTTERFLY VALVE  
SALES REFERENCE DRAWINGS

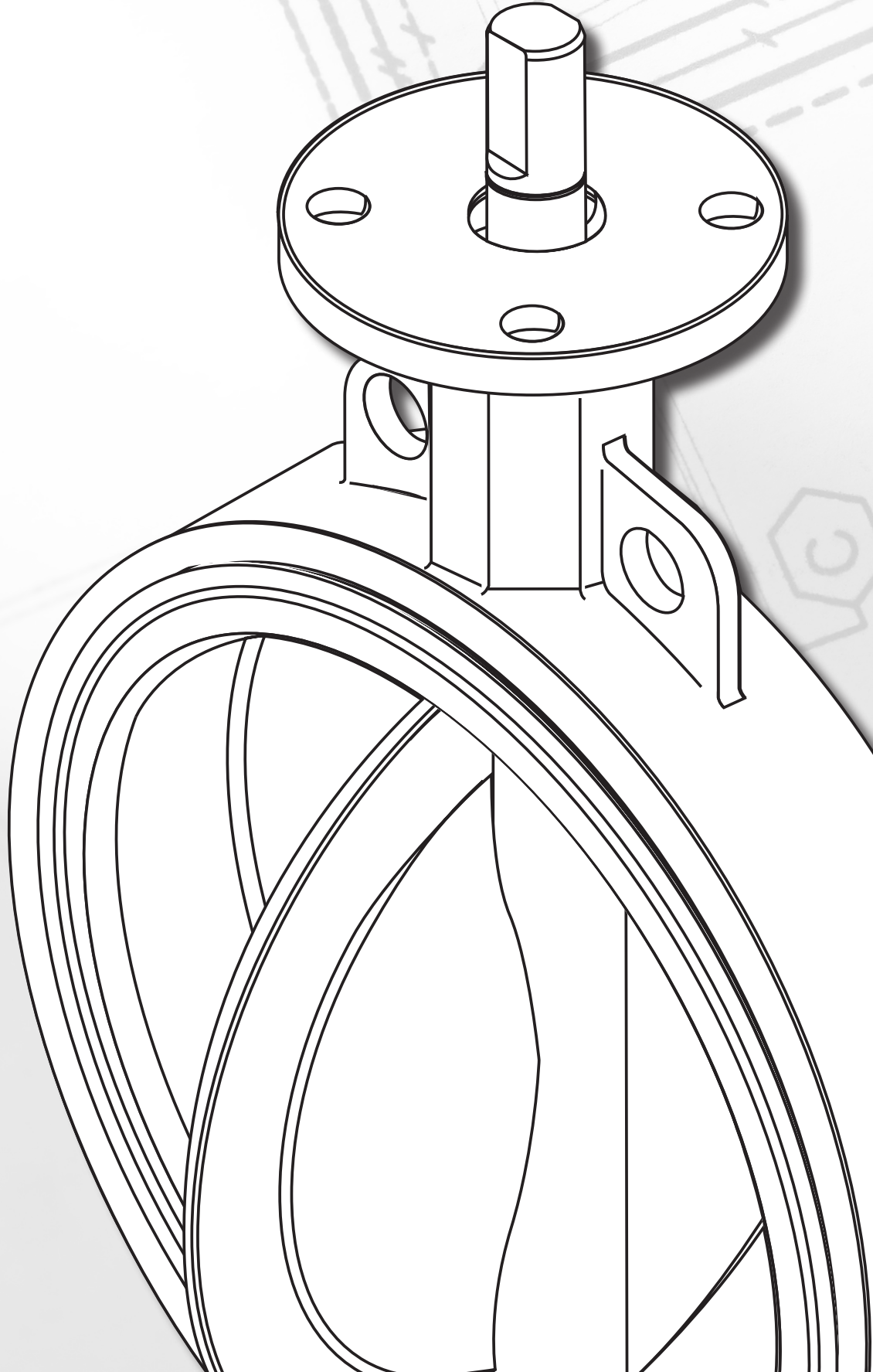

### TABLE OF CONTENTS

Series 20/21 (1" -12" / 25mm-300mm) .....	2
Series 20/21 (14" -20" / 350mm-500mm) .....	3
Series 22/23 (2" -12" / 50mm-300mm) .....	4
Series 22/23 (14" -20" / 350mm-500mm) .....	5
Series 30/31 (2" -12" / 50mm-300mm) .....	6
Series 30/31 (14" -20" / 350mm-500mm) .....	7
Series 32/33 (22" -36" / 550mm-900mm) .....	8
Series 3A & 3AH (2" -12" / 50mm-300mm).....	9
Series 3A & 3AH (14" -20" / 350mm-500mm).....	10
Series 31H (2" -12" / 50mm-300mm).....	11
Series 31H (14" -20" / 350mm-500mm).....	12
Series 35/36 (22" -96") Imperial.....	13
Series 35/36 (550mm-2400mm) Metric.....	14
Series 35F (22" -36" / 550mm-900mm).....	15



**Series 21 Lug**

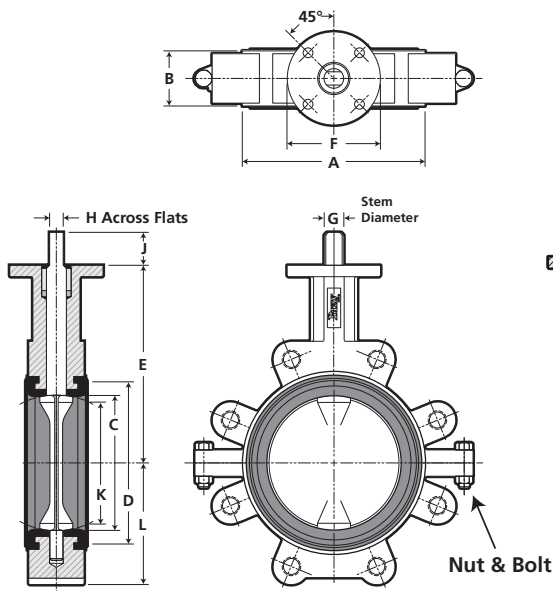

**Series 20 Wafer**

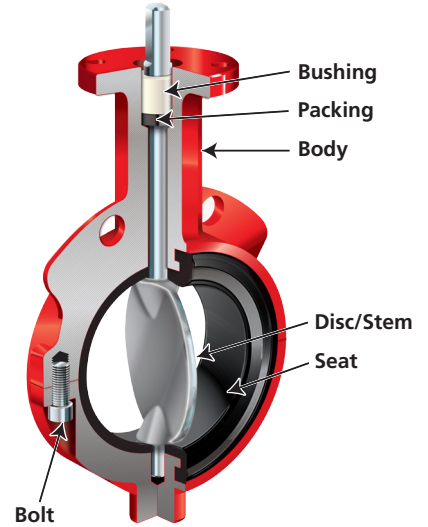
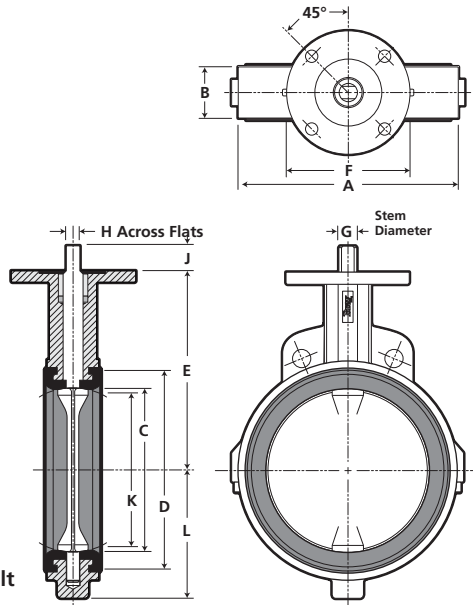

IMPERIAL DIMENSIONS: Inches																			Lug Bolting Data		
Valve Size	A	B	C	D	E	F	Top Plate Drilling			G	H	J	K	L		Adapter Code	Weight (lbs.)		Bolt Circle	No of Holes	Threads ISO Coarse
							BC	No of Holes	Hole Diameter					Wafer	Lug		Wafer	Lug			
1	2.36	1.18	1.25	1.73	3.54	2.56	1.97	4	.28	.39	.32	1.00	.44	1.65	1.65	AA	2.0	3.0	3.12	4	1/2-13
1 1/2	3.16	1.26	1.84	2.53	4.12	2.56	1.97	4	.28	.39	.32	1.00	1.35	2.15	2.15	AA	3.0	4.5	3.88	4	1/2-13
2	3.69	1.62	2.00	2.84	5.50	3.54	2.76	4	.39	.55	.39	1.25	1.32	2.22	2.30	A	5.5	7.0	4.75	4	5/8-11
2 1/2	4.19	1.75	2.50	3.34	6.00	3.54	2.76	4	.39	.55	.39	1.25	1.91	2.47	2.57	A	6.5	9.0	5.50	4	5/8-11
3	4.88	1.75	3.00	4.03	6.25	3.54	2.76	4	.39	.55	.39	1.25	2.55	2.81	2.81	A	7.0	9.5	6.00	4	5/8-11
4	6.06	2.00	4.00	5.16	7.00	3.54	2.76	4	.39	.63	.43	1.25	3.57	3.56	4.09	B	11.0	16.0	7.50	8	5/8-11
5	7.12	2.12	5.00	6.16	7.50	3.54	2.76	4	.39	.75	.51	1.25	4.63	4.28	4.61	C	14.0	22.0	8.50	8	3/4-10
6	8.12	2.12	5.75	7.02	8.00	3.54	2.76	4	.39	.75	.51	1.25	5.45	4.78	5.08	C	17.0	25.0	9.50	8	3/4-10
8	10.50	2.50	7.75	9.47	9.50	5.91	4.92	4	.57	.87	.63	1.25	7.45	6.03	6.12	D	32.0	45.0	11.75	8	3/4-10
10	12.75	2.50	9.75	11.47	10.75	5.91	4.92	4	.57	1.18	.87	2.00	9.53	7.41	7.69	E	47.0	66.0	14.25	12	7/8-9
12	14.88	3.00	11.75	13.47	12.25	5.91	4.92	4	.57	1.18	.87	2.00	11.47	8.41	9.02	E	68.0	102.0	17.00	12	7/8-9

Note: K dimension is disc chordal dimension at valve face.

METRIC DIMENSIONS: Millimeters																			Lug Bolting Data		
Valve Size	A	B	C	D	E	F	Top Plate Drilling			G	H	J	K	L		Adapter Code	Weight (Kg)		Bolt Circle	No of Holes	Threads ISO Coarse
							BC	No of Holes	Hole Diameter					Wafer	Lug		Wafer	Lug			
25	60	30	32	44	90	65	50	4	7	10	8	25	11	42	42	AA	0.9	1.4	85	4	M12
40	80	33	47	64	105	65	50	4	7	10	8	25	35	55	55	AA	1.3	2.0	110	4	M12
50	94	43	51	72	140	90	70	4	10	14	10	32	31	56	56	A	2.5	3.2	125	4	M16
65	106	46	64	85	152	90	70	4	10	14	10	32	47	63	63	A	2.9	4.1	145	4	M16
80	124	46	76	102	159	90	70	4	10	14	10	32	63	71	71	A	3.2	4.3	160	8	M16
100	154	52	102	131	178	90	70	4	10	16	11	32	90	90	90	B	5	7.2	180	8	M16
125	181	56	127	156	190	90	70	4	10	19	13	32	116	109	109	C	6.4	10	210	8	M20
150	206	56	146	178	203	90	70	4	10	19	13	32	137	121	121	C	7.7	11.3	240	8	M20
200	267	60	197	240	241	150	125	4	14	22	16	32	190	153	153	D	14.5	20.4	295	8	M20
250	324	68	248	291	273	150	125	4	14	30	22	51	240	188	188	E	21.3	30	355	12	M22
300	378	78	298	342	311	150	125	4	14	30	22	51	290	214	214	E	30.8	46.3	410	12	M22

Note: K dimension is disc chordal dimension at valve face.

Drawings are for reference only. Please refer to Bray ES drawings on the Bray website, www.bray.com. Bray reserves the right to change product dimensions without notice.

**SR Drawing #20/21-1/12-in** January - 2015

Inquire/P.O. No.: \_\_\_\_\_

Customer/Project: \_\_\_\_\_

Bray Order No.: \_\_\_\_\_

**Series 20 Wafer**

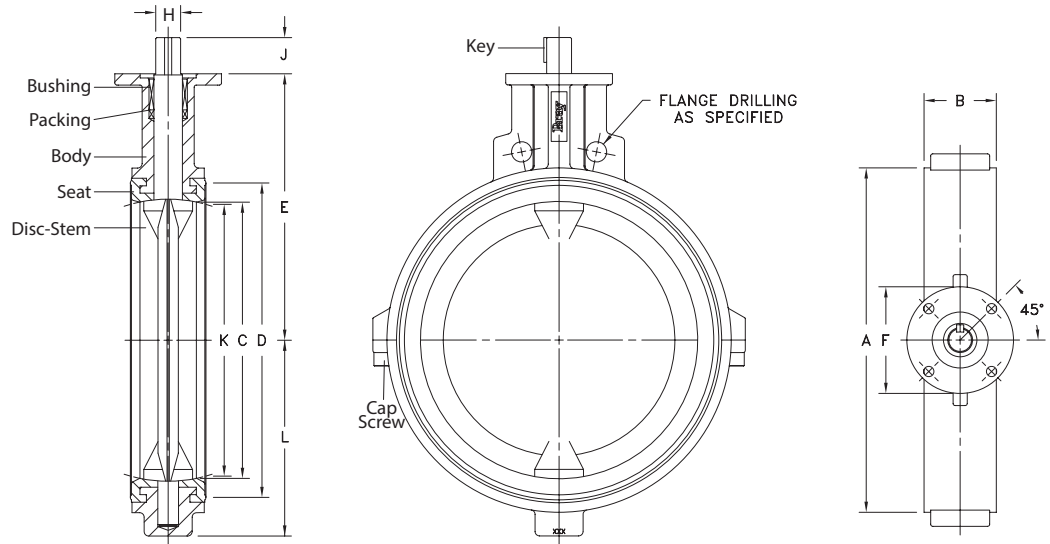

**Series 21 Lug**

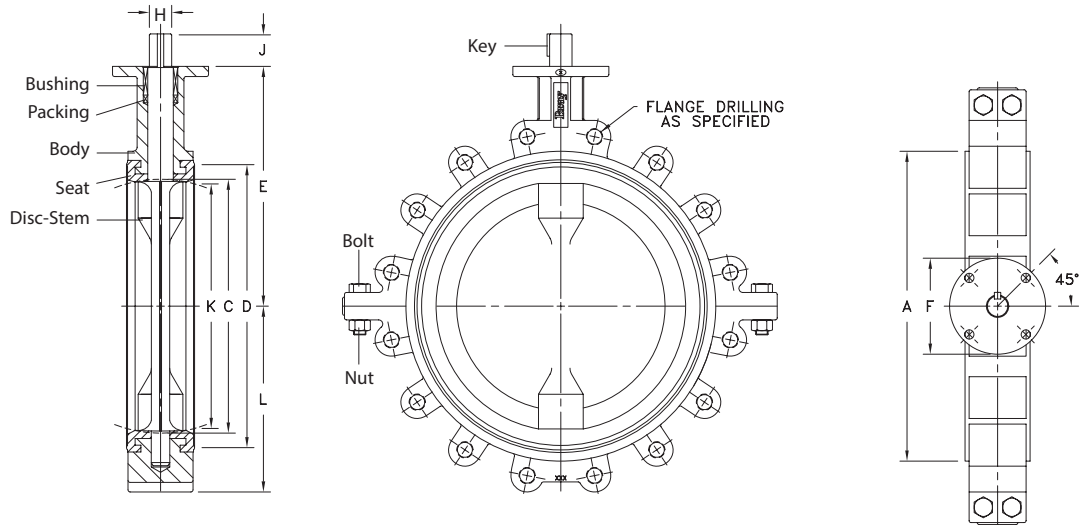

IMPERIAL DIMENSIONS: Inches																	Lug Bolting Data				
Valve Size	A	B	C	D	E	F	Top Plate Drilling			H	J	Key Size	K	L		Adapter Code	Weight (lbs.)		Bolt Circle	No of Holes	Threads ISO Coarse
							BC	No of Holes	Hole Diameter					Wafer	Lug		Wafer	Lug			
14	17.05	3.00	13.25	15.28	13.62	5.91	4.92	4	.57	1.38	2.00	.39x.39	13.04	9.61	9.93	F	96.5	120	18.75	12	1.00-8
16	19.21	4.00	15.25	17.41	14.75	5.91	4.92	4	.57	1.38	2.00	.39x.39	14.85	11.52	11.51	F	134	172	21.25	16	1.00-8
18	21.12	4.25	17.25	19.47	16.00	8.27	6.50	4	.81	1.97	2.50	.47x.39	16.85	13.44	13.44	G	203	236	22.75	16	1.12-7
20	23.25	5.00	19.25	21.59	17.25	8.27	6.50	4	.81	1.97	2.50	.47x.39	18.73	14.46	14.46	G	264	312	25.00	20	1.12-7

Note: K dimension is disc chordal dimension at valve face.

METRIC DIMENSIONS: Millimeters																	Lug Bolting Data				
Valve Size	A	B	C	D	E	F	Top Plate Drilling			H	J	Key Size	K	L		Adapter Code	Weight (Kg)		Bolt Circle	No of Holes	Threads ISO Coarse
							BC	No of Holes	Hole Diameter					Wafer	Lug		Wafer	Lug			
350	433	76	336	388	346	150	125	4	14	35	51	10x10	331	244	252	F	44	44	460	12	M24
400	488	102	387	442	375	150	125	4	14	35	51	10x10	377	293	292	F	61	61	515	16	M24
450	536	108	438	494	406	210	165	4	20	50	64	12x10	428	341	341	G	92	92	565	16	M30
500	590	127	489	548	438	210	165	4	20	50	64	12x10	476	367	367	G	120	120	620	20	M30

Note: K dimension is disc chordal dimension at valve face.

Drawings are for reference only. Please refer to Bray ES drawings on the Bray website, www.bray.com. Bray reserves the right to change product dimensions without notice.

**SR Drawing #20/21-14/20-in** January - 2015

Inquire/P.O. No.: \_\_\_\_\_

Customer/Project: \_\_\_\_\_

Bray Order No.: \_\_\_\_\_

**Series 23 Lug**

**Series 22 Wafer**

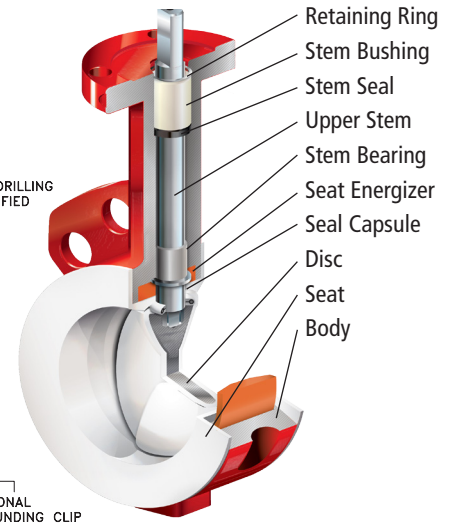
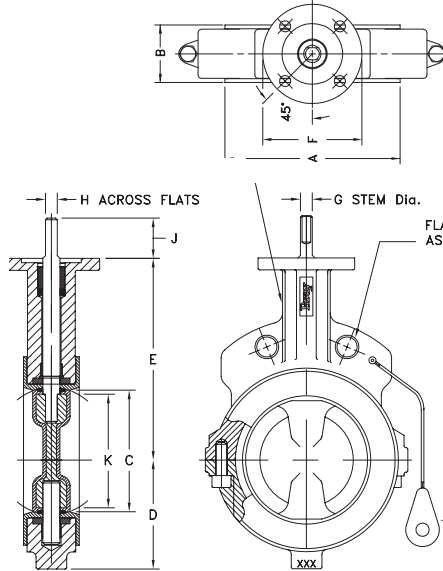
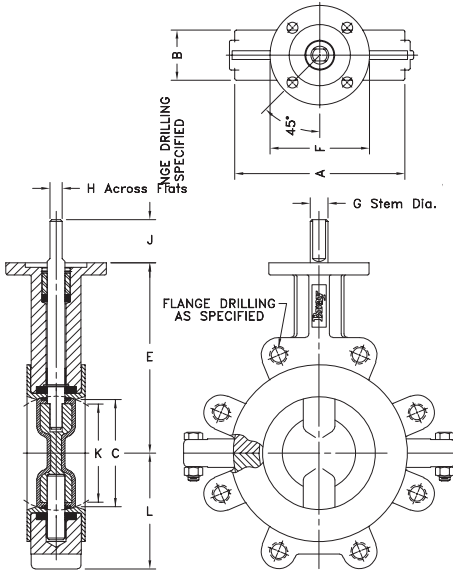

IMPERIAL DIMENSIONS: Inches																	Lug Bolting Data			
Valve Size	A	B	C	E	F	Top Plate Drilling			G	H	J	K	L		Adapter Code	Weight (lbs.)		Bolt Circle	No of Holes	Threads ISO Coarse
						BC	No of Holes	Hole Diameter					Wafer	Lug		Wafer	Lug			
2	3.88	1.69	2.00	5.50	3.54	2.76	4	.39	.55	.39	1.25	1.13	2.22	2.30	A	6.5	8.0	4.75	4	5/8-11
2 1/2	4.38	1.81	2.50	6.00	3.54	2.76	4	.39	.55	.39	1.25	1.77	2.47	2.57	A	7.5	10.0	5.50	4	5/8-11
3	5.00	1.81	3.00	6.25	3.54	2.76	4	.39	.55	.39	1.25	2.44	2.81	2.81	A	8.5	11.0	6.00	4	5/8-11
4	6.25	2.05	4.00	7.00	3.54	2.76	4	.39	.63	.43	1.25	3.48	3.56	4.09	B	13.5	17.5	7.50	8	5/8-11
5	7.38	2.20	5.00	7.50	3.54	2.76	4	.39	.75	.51	1.25	4.53	4.28	4.61	C	16.0	21.0	8.50	8	3/4-10
6	8.50	2.20	5.75	8.00	3.54	2.76	4	.39	.75	.51	1.25	5.35	4.78	5.06	C	20.5	28.5	9.50	8	3/4-10
8	10.62	2.36	7.75	9.50	5.91	4.92	4	.57	.87	.63	1.25	7.43	6.03	6.05	D	38.5	51.5	11.75	8	3/4-10
10	12.75	2.68	9.75	10.75	5.91	4.92	4	.57	1.18	.87	2.00	9.42	7.41	7.69	E	62.0	76.0	14.25	12	7/8-9
12	14.88	3.07	11.75	12.25	5.91	4.92	4	.57	1.18	.87	2.00	11.39	8.41	9.02	E	76.0	116.0	17.00	12	7/8-9

Note: K dimension is disc chordal dimension at valve face.

METRIC DIMENSIONS: Millimeters																	Lug Bolting Data			
Valve Size	A	B	C	E	F	Top Plate Drilling			G	H	J	K	L		Adapter Code	Weight (Kg)		Bolt Circle	No of Holes	Threads ISO Coarse
						BC	No of Holes	Hole Diameter					Wafer	Lug		Wafer	Lug			
50	98	43	51	140	90	70	4	10	14	10	32	29	56	58	A	3	3.5	121	4	5/8-11
65	111	46	64	152	90	70	4	10	14	10	32	45	63	63	A	3.5	4.5	140	4	5/8-11
80	127	46	76	159	90	70	4	10	14	10	32	62	71	71	A	4	5	152	4	5/8-11
100	159	52	102	178	90	70	4	10	16	11	32	88	90	104	B	6	8	191	8	5/8-11
125	187	56	127	190	90	70	4	10	19	13	32	115	109	117	C	7	10	216	8	3/4-10
150	216	56	146	203	90	70	4	10	19	13	32	136	121	129	C	9	13	241	8	3/4-10
200	270	60	197	241	150	125	4	14	22	16	32	189	153	155	D	17	23	298	8	3/4-10
250	324	68	248	273	150	125	4	14	30	22	51	239	188	195	E	28	34	362	12	7/8-9
300	378	78	298	311	150	125	4	14	30	22	51	289	214	229	E	34	53	432	12	7/8-9

Note: K dimension is disc chordal dimension at valve face.

Drawings are for reference only. Please refer to Bray ES drawings on the Bray website, www.bray.com. Bray reserves the right to change product dimensions without notice.

Inquire/P.O. No.: \_\_\_\_\_

Bray Order No.: \_\_\_\_\_

**SR Drawing #22/23-2/12-im** January - 2015

Customer/Project: \_\_\_\_\_

**Series 22 Wafer**

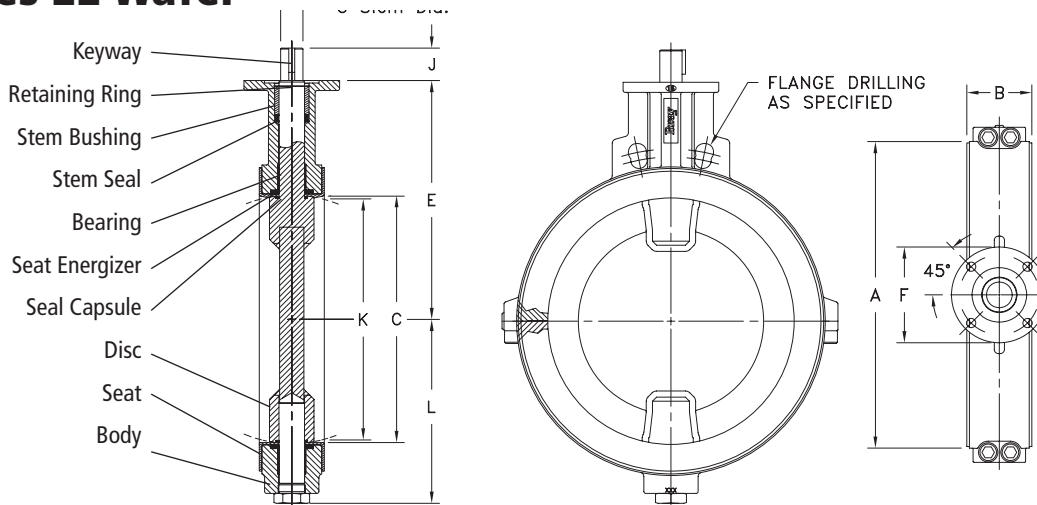

**Series 23 Lug**

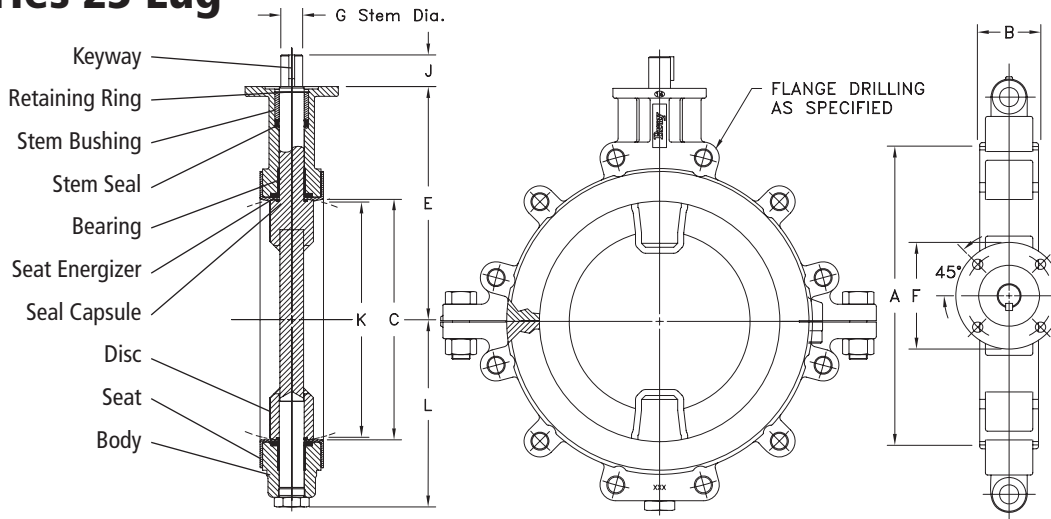

IMPERIAL DIMENSIONS: Inches														Lug Bolting Data						
Valve Size	A	B	C	E	F	Top Plate Drilling			G	J	Key Size	K	L		Adapter Code	Weight (lbs.)		Bolt Circle	No of Holes	Threads ISO Coarse
						BC	No of Holes	Hole Diameter					Wafer	Lug		Wafer	Lug			
14	17.05	3.07	13.25	13.62	5.91	4.92	4	.57	1.38	2.00	.39x.39	13.00	10.02	10.02	F	125	148	18.75	12	1.00-8
16	19.21	4.02	15.25	14.75	5.91	4.92	4	.57	1.38	2.00	.39x.39	14.75	11.99	11.99	F	180	218	21.25	16	1.00-8
18	21.12	4.49	17.25	16.00	8.27	6.50	4	.81	1.97	2.50	.39x.47	16.65	13.94	13.94	G	240	273	22.75	16	1.13-7
20	23.25	5.00	19.25	17.25	8.27	6.50	4	.81	1.97	2.50	.39x.47	18.73	14.94	14.94	G	320	368	25.00	20	1.13-7

Note: K dimension is disc chordal dimension at valve face.

METRIC DIMENSIONS: Millimeters														Lug Bolting Data						
Valve Size	A	B	C	E	F	Top Plate Drilling			G	J	Key Size	K	L		Adapter Code	Weight (Kg)		Bolt Circle	No of Holes	Threads ISO Coarse
						BC	No of Holes	Hole Diameter					Wafer	Lug		Wafer	Lug			
350	433	78	337	346	150	125	4	14	35	51	10x10	330	255	255	F	57	67	476	12	1.00-8
400	488	102	387	375	150	125	4	14	35	51	10x10	375	305	305	F	82	99	540	16	1.00-8
450	536	114	438	406	210	165	4	21	50	64	10x12	423	354	354	G	109	124	578	16	1.13-7
500	591	127	489	438	210	165	4	21	50	64	10x12	476	379	379	G	145	167	635	20	1.13-7

Note: K dimension is disc chordal dimension at valve face.

Drawings are for reference only. Please refer to Bray ES drawings on the Bray website, www.bray.com. Bray reserves the right to change product dimensions without notice.

**SR Drawing #22/23-14/20-im** January - 2015

Inquire/P.O. No.: \_\_\_\_\_

Customer/Project: \_\_\_\_\_

Bray Order No.: \_\_\_\_\_

**Series 31 Lug**

**Series 30 Wafer**

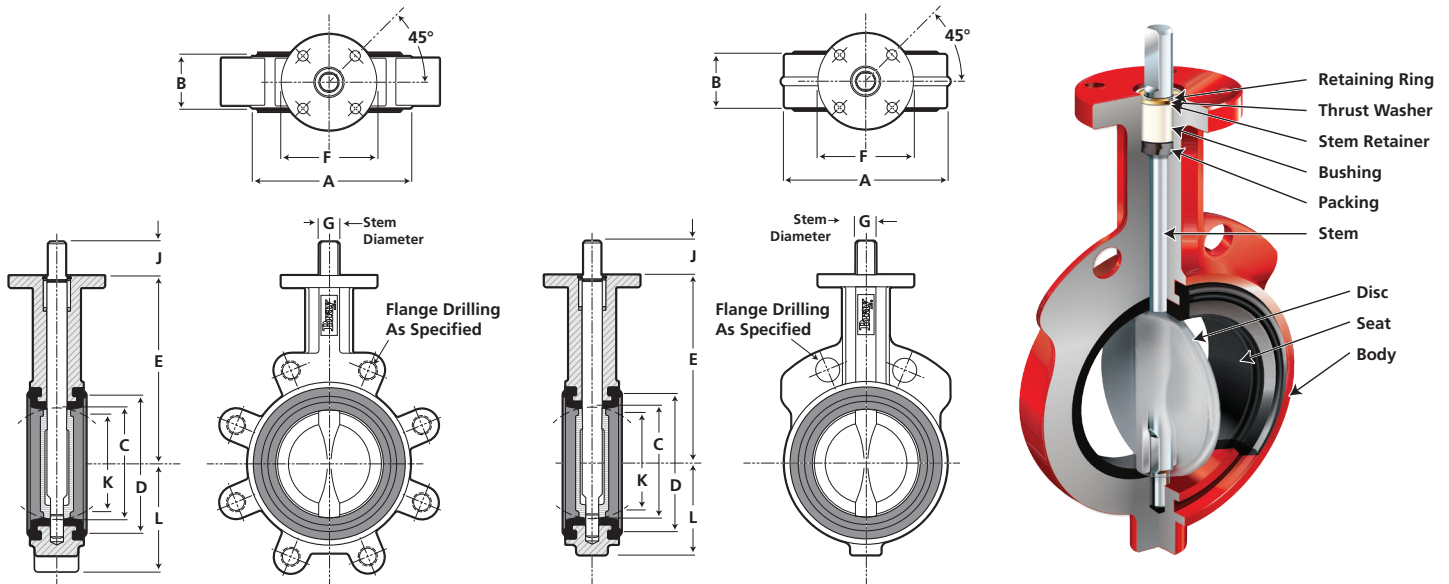

IMPERIAL DIMENSIONS: Inches																	Lug Bolting Data				
Valve Size	A	B	C	D	E	F	Top Plate Drilling			G	H	J	K	L		Adapter Code	Weight (lbs.)		Bolt Circle	No of Holes	Threads ISO Coarse
							BC	No of Holes	Hole Diameter					Wafer	Lug		Wafer	Lug			
2	3.69	1.62	2.00	2.85	5.50	3.54	2.76	4	.39	.55	.39	1.25	1.32	2.22	2.30	A	5.5	7.0	4.75	4	.62-11
2 1/2	4.19	1.75	2.50	3.36	6.00	3.54	2.76	4	.39	.55	.39	1.25	1.91	2.47	2.57	A	7.0	8.0	5.50	4	.62-11
3	4.88	1.75	3.00	4.15	6.25	3.54	2.76	4	.39	.55	.39	1.25	2.55	2.81	2.81	A	7.5	9.0	6.00	4	.62-11
4	6.06	2.00	4.00	5.16	7.00	3.54	2.76	4	.39	.63	.43	1.25	3.57	3.41	4.09	B	11.5	15.0	7.50	8	.62-11
5	7.06	2.12	5.00	6.16	7.50	3.54	2.76	4	.39	.75	.51	1.25	4.63	4.03	4.61	C	14.0	20.0	8.50	8	.75-10
6	8.12	2.12	5.75	7.02	8.00	3.54	2.76	4	.39	.75	.51	1.25	5.45	4.53	5.06	C	17.0	23.0	9.50	8	.75-10
8	10.50	2.50	7.75	9.47	9.50	5.91	4.92	4	.57	.87	.63	1.25	7.45	5.75	6.05	D	34.0	42.0	11.75	12	.75-10
10	12.75	2.50	9.75	11.47	10.72	5.91	4.92	4	.57	1.18	.87	2.00	9.53	7.12	7.69	E	49.0	66.0	14.25	12	.88-9
12	14.88	3.00	11.75	13.47	12.25	5.91	4.92	4	.57	1.18	.87	2.00	11.47	8.12	9.02	E	67.0	88.0	17.00	12	.88-9

Note: K dimension is disc chordal dimension at valve face.

METRIC DIMENSIONS: Millimeters																	Lug Bolting Data				
Valve Size	A	B	C	D	E	F	Top Plate Drilling			G	H	J	K	L		Adapter Code	Weight (Kg)		Bolt Circle	No of Holes	Threads ISO Coarse
							BC	No of Holes	Hole Diameter					Wafer	Lug		Wafer	Lug			
50	94	43	51	72	140	90	70	4	10	14	10	32	34	56	58	A	2.5	3	121	4	.62-11
65	106	46	64	85	152	90	70	4	10	14	10	32	49	63	65	A	3	3.5	140	4	.62-11
80	124	46	76	102	159	90	70	4	10	14	10	32	65	71	71	A	3.5	4	152	4	.62-11
100	154	52	102	131	178	90	70	4	10	16	11	32	91	87	104	B	5	7	191	8	.62-11
125	181	56	127	156	190	90	70	4	10	19	13	32	118	102	117	C	6	9	216	8	.75-10
150	206	56	146	178	203	90	70	4	10	19	13	32	138	115	129	C	8	10	241	8	.75-10
200	267	60	197	240	241	150	125	4	14	22	16	32	189	146	154	D	15	19	298	12	.75-10
250	324	68	248	291	273	150	125	4	14	30	22	51	242	181	195	E	22	30	362	12	.88-9
300	378	76	298	342	311	150	125	4	14	30	22	51	291	206	229	E	30	40	432	12	.88-9

Note: K dimension is disc chordal dimension at valve face.

Drawings are for reference only. Please refer to Bray ES drawings on the Bray website, www.bray.com. Bray reserves the right to change product dimensions without notice.

**SR Drawing #30/31-2/12-im** January - 2015

Customer/Project: \_\_\_\_\_

Inquire/P.O. No.: \_\_\_\_\_

Bray Order No.: \_\_\_\_\_

**Series 30 Wafer**

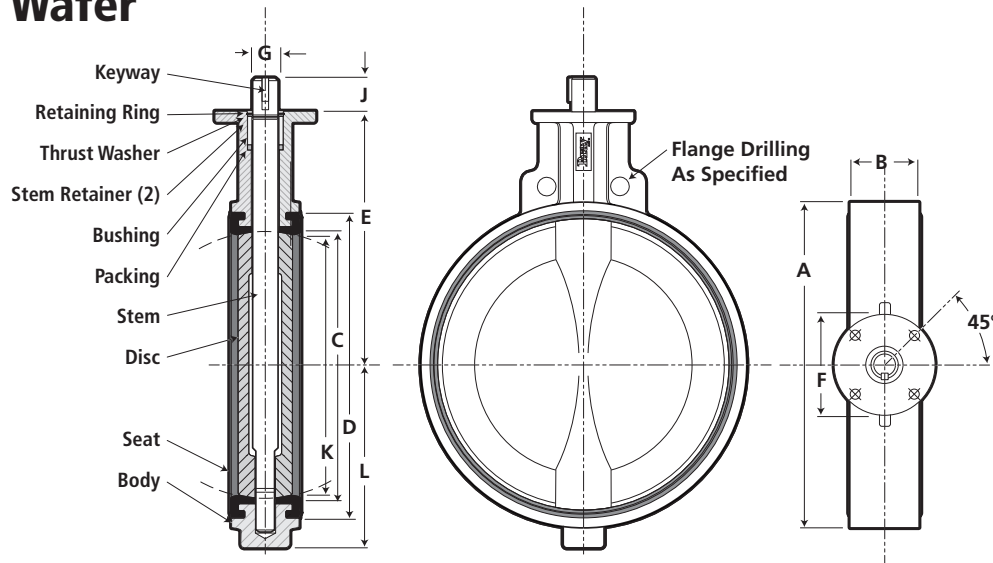

**Series 31 Lug**

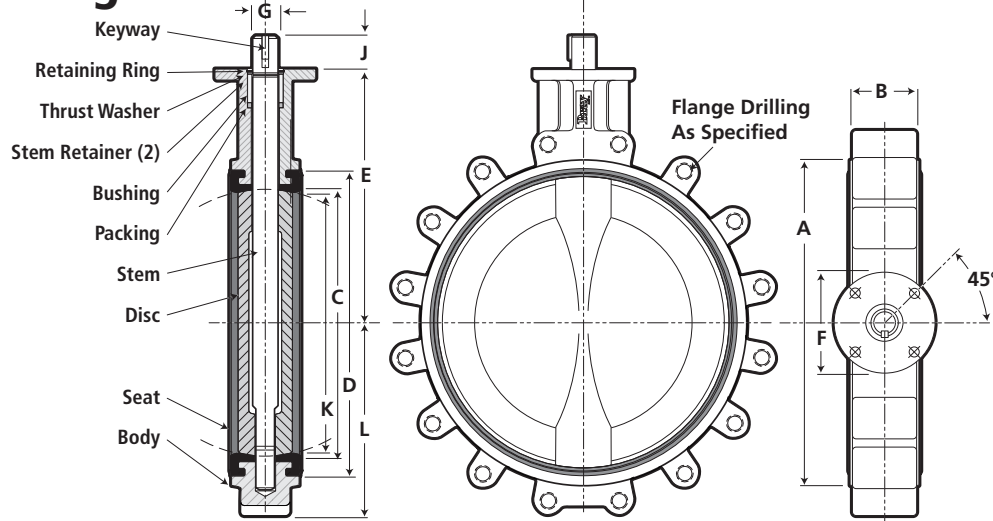

IMPERIAL DIMENSIONS: Inches																	Lug Bolting Data				
Valve Size	A	B	C	D	E	F	Top Plate Drilling			G	J	Key Size	K	L		Adapter Code	Weight (lbs.)		Bolt Circle	No of Holes	Threads ISO Coarse
							BC	No of Holes	Hole Diameter					Wafer	Lug		Wafer	Lug			
14	17.05	3.00	13.25	15.28	13.62	5.91	4.92	4	.57	1.38	2.00	.39x.39	13.04	9.38	9.93	F	95	114	18.75	12	1.00-8
16	19.21	4.00	15.25	17.14	14.75	5.91	4.92	4	.57	1.38	2.00	.39x.39	14.85	10.75	11.30	F	135	166	21.25	16	1.00-8
18	21.12	4.25	17.25	19.47	16.00	8.27	6.50	4	.81	1.97	2.50	.47x.39	16.85	12.00	12.15	G	200	226	22.75	16	1.12-7
20	23.25	5.00	19.25	21.59	17.25	8.27	6.50	4	.81	1.97	2.50	.47x.39	18.73	14.00	14.00	G	260	305	25.00	20	1.12-7

Note: K dimension is disc chordal dimension at valve face.

METRIC DIMENSIONS: Millimeters																	Lug Bolting Data				
Valve Size	A	B	C	D	E	F	Top Plate Drilling			G	J	Key Size	K	L		Adapter Code	Weight (Kg)		Bolt Circle	No of Holes	Threads ISO Coarse
							BC	No of Holes	Hole Diameter					Wafer	Lug		Wafer	Lug			
350	433	76	337	388	346	150	125	4	14	35	51	10x10	331	238	252	F	43	52	476	12	1.00-8
400	488	102	387	442	375	150	125	4	14	35	51	10x10	377	273	287	F	61	75	540	16	1.00-8
450	536	108	438	495	406	210	165	4	21	50	64	12x10	428	305	309	G	91	103	578	16	1.12-7
500	591	127	489	548	438	210	165	4	21	50	64	12x10	476	348	358	G	118	138	635	20	1.12-7

Note: K dimension is disc chordal dimension at valve face.

Drawings are for reference only. Please refer to Bray ES drawings on the Bray website, www.bray.com. Bray reserves the right to change product dimensions without notice.

SR Drawing #30/31-14/20-im January - 2015

Inquire/P.O. No.: \_\_\_\_\_

Customer/Project: \_\_\_\_\_

Bray Order No.: \_\_\_\_\_

**Series 32/33 Wafer**

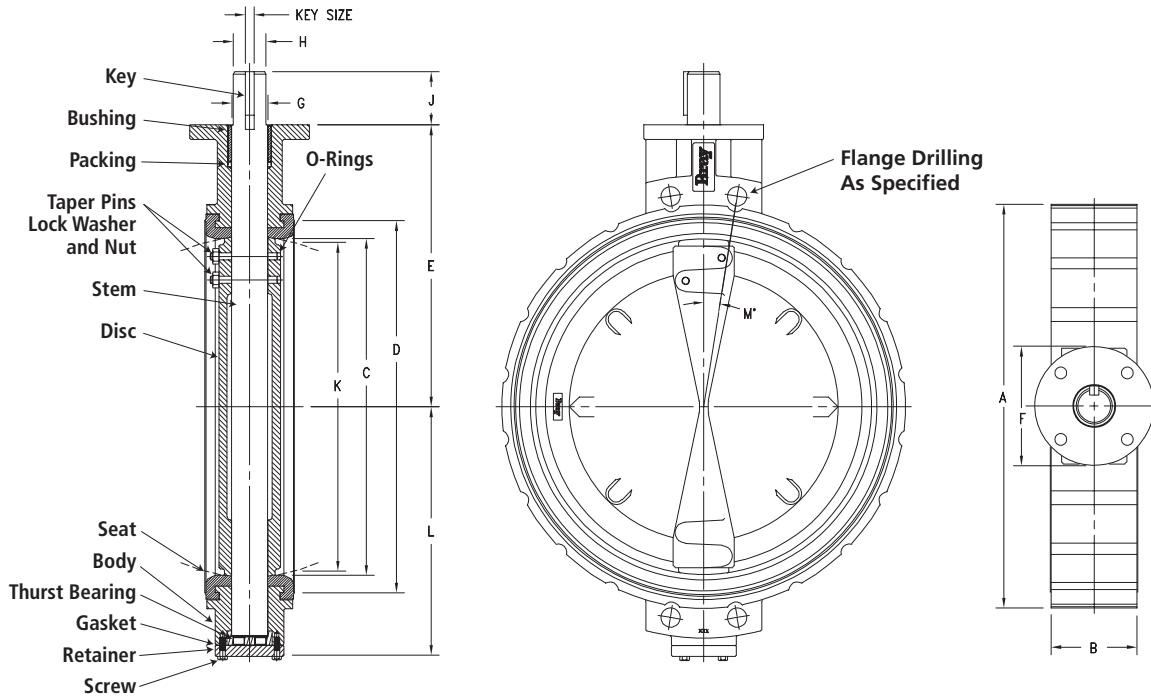

**IMPERIAL DIMENSIONS: Inches**

Valve Size	Ins							Mounting Flange Drig.			SERIES 32				SERIES 33				Weight (lbs.)	
		A	B	C	D	E	F	PCD	No. Holes	Hole Dia.	G	H	J	Key Size	K	H	J	Key Size		K
22	25.50	6.06	21.27	24.12	20.12	8.27	6.50	4	.81	2.50	2.50	4.00	.62x.62	20.51	2.50	4.00	.62x.62	20.56	16.56	400
24	27.94	5.94	23.28	25.75	19.50	8.27	6.50	4	.81	2.50	2.50	4.00	.62x.62	22.65	2.50	4.00	.62x.62	22.70	17.56	420
26	29.50	6.50	24.46	27.83	21.83	11.81	10.00	8	.71	2.50	2.50	4.00	.62x.62	23.71	2.50	4.00	.62x.62	23.76	18.82	540
28	31.11	6.50	26.46	29.83	22.84	11.81	10.00	8	.71	2.50	2.50	4.00	.62x.62	25.74	2.50	4.00	.62x.62	25.78	19.83	580
30	34.13	6.56	29.29	32.14	23.00	11.81	10.00	8	.71	3.00	2.50	4.00	.62x.62	28.68	3.00	4.00	.75x.75	28.73	20.81	660
32	35.55	7.48	30.39	33.78	26.38	11.81	10.00	8	.71	3.00	2.50	4.00	.62x.62	29.59	3.00	4.00	.75x.75	29.65	21.94	785
34	38.75	7.88	33.00	35.82	26.93	13.78	11.73	8	.81	3.50	3.00	4.00	.75x.75	32.18	3.50	5.25	.88x.62	32.22	23.66	905
36	40.69	7.88	35.30	38.25	27.75	13.78	11.73	8	.81	3.50	3.00	4.00	.75x.75	34.57	3.50	5.25	.88x.62	34.62	24.94	1025

Note: K dimension is disc chordal dimension at valve face.

**METRIC DIMENSIONS: Millimeters**

Valve Size	mm							Mounting Flange Drig.			SERIES 32				SERIES 33				Weight (kg)	
		A	B	C	D	E	F	PCD	No. Holes	Hole Dia.	G	H	J	Key Size	K	H	J	Key Size		K
550	648	154	540	611	511	210	165	4	21	63.5	63.5	101.6	18.11	521	63.5	101.6	18x11	522	419	181
600	710	151	591	654	495	210	165	4	21	63.5	63.5	101.6	18.11	575	63.5	101.6	18x11	576	446	191
650	749	165	621	707	554	300	254	8	18	63.5	63.5	101.6	18.11	601	63.5	101.6	18x11	602	478	245
700	790	165	672	756	580	300	254	8	18	63.5	63.5	101.6	18.11	654	63.5	101.6	18x11	655	502	263
750	868	167	744	813	584	210	165	4	18	76.2	63.5	101.6	18.11	728	76.2	101.6	20x12	730	529	299
800	903	190	772	856	670	300	254	8	18	76.2	63.5	101.6	18.11	751	76.2	101.6	20x12	752	556	356
850	984	200	838	908	684	350	298	8	21	88.9	76.2	101.6	20x12	817	88.9	133.4	22x14	818	599	411
900	1034	200	899	972	705	273	216	8	21	88.9	76.2	101.6	20x12	817	88.9	133.4	22x14	879	633	465

Note: K dimension is disc chordal dimension at valve face.

Drawings are for reference only. Please refer to Bray ES drawings on the Bray website, www.bray.com. Bray reserves the right to change product dimensions without notice.

**SR Drawing #32/33-22/36-im** January - 2015

Inquire/P.O. No.: \_\_\_\_\_

Customer/Project: \_\_\_\_\_

Bray Order No.: \_\_\_\_\_

**Series 3A Double Flange**

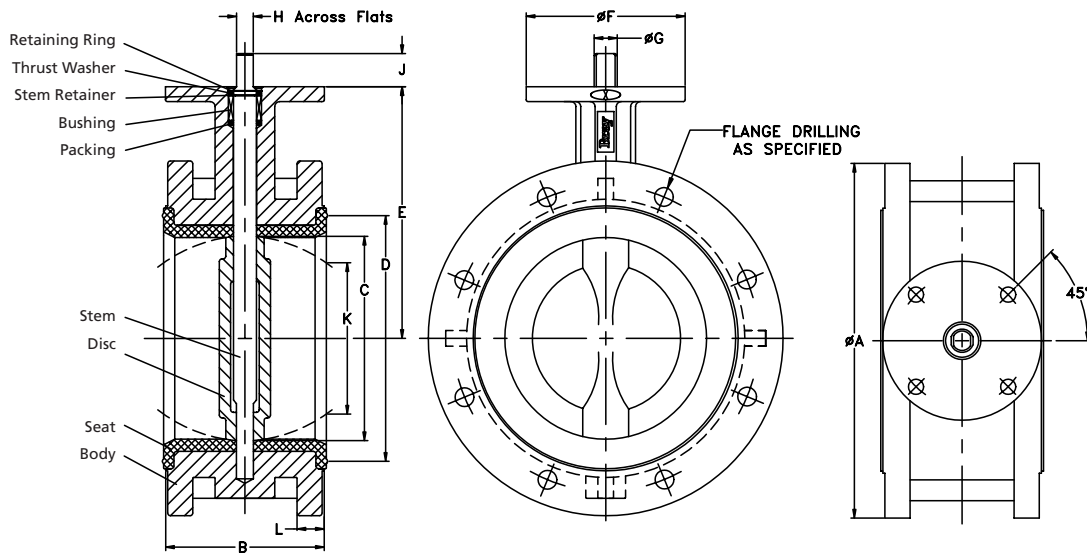

IMPERIAL DIMENSIONS: Inches																Flange Bolting Data			
Valve Size	A	B	C	D	E	F	Top Plate Drilling			G	H	J	K	L	Adapter Code	Weight (lbs.)	Bolt Circle	No of Holes	Threads ISO Coarse
							BC	No of Holes	Hole Diameter										
2	6.50	4.25	2.00	2.84	5.50	3.54	2.76	4	.39	.55	.39	1.25	X	.79	A	22	4.75	4	5/8-11
2.5	7.28	4.41	2.50	3.34	6.00	3.54	2.76	4	.39	.55	.39	1.25	X	.79	A	24	5.50	4	5/8-11
3	7.87	4.49	3.00	4.03	6.25	3.54	2.76	4	.39	.55	.39	1.25	X	.87	A	28	6.00	4	5/8-11
4	8.66	5.00	4.00	5.16	7.00	3.54	2.76	4	.39	.63	.43	1.25	X	.95	B	35	7.50	8	5/8-11
5	9.84	5.51	5.00	6.16	7.50	3.54	2.76	4	.39	.75	.51	1.25	X	1.03	C	45	8.50	8	3/4-10
6	11.22	5.51	5.75	7.02	8.00	3.54	2.76	4	.39	.75	.51	1.25	1.78	1.03	C	59	9.50	8	3/4-10
8	13.50	5.98	7.75	9.47	9.50	5.91	4.92	4	.57	.87	.63	1.25	5.00	1.18	D	70	11.75	8	3/4-10
10	15.94	6.50	9.75	11.47	10.75	5.91	4.92	4	.57	1.18	.87	2.00	7.35	1.26	E	132	14.25	12	7/8-9
12	19.00	7.01	11.75	13.47	12.25	5.91	4.92	4	.57	1.18	.87	2.00	9.53	1.26	E	178	17.00	12	7/8-9

Note: K dimension is disc chordal dimension at valve face.

METRIC DIMENSIONS: Millimeters																Flange Bolting Data			
Valve Size	A	B	C	D	E	F	Top Plate Drilling			G	H	J	K	L	Adapter Code	Weight (kg)	Bolt Circle	No of Holes	Threads ISO Coarse
							BC	No of Holes	Hole Diameter										
50	165	108	51	72	140	90	70	4	9.9	14	10	32	X	20	A	10	121	4	5/8-11
65	185	112	64	85	152	90	70	4	9.9	14	10	32	X	20	A	11	140	4	5/8-11
80	200	114	76	102	159	90	70	4	9.9	14	10	32	X	22	A	13	152	4	5/8-11
100	220	127	102	131	178	90	70	4	9.9	16	11	32	X	24	B	16	191	8	5/8-11
125	250	140	146	178	203	90	70	4	9.9	19	13	32	X	26	C	20	216	8	3/4-10
150	285	140	146	178	203	90	70	4	9.9	19	13	32	45	26	C	27	241	8	3/4-10
200	343	152	197	241	241	150	125	4	14.5	22	16	32	127	30	D	32	298	8	3/4-10
250	405	165	248	291	273	150	125	4	14.5	30	22	51	187	32	E	60	362	12	7/8-9
300	483	178	298	342	311	150	125	4	14.5	30	22	51	242	32	E	81	432	12	7/8-9

Note: K dimension is disc chordal dimension at valve face.

**Series 3A Double Flange**

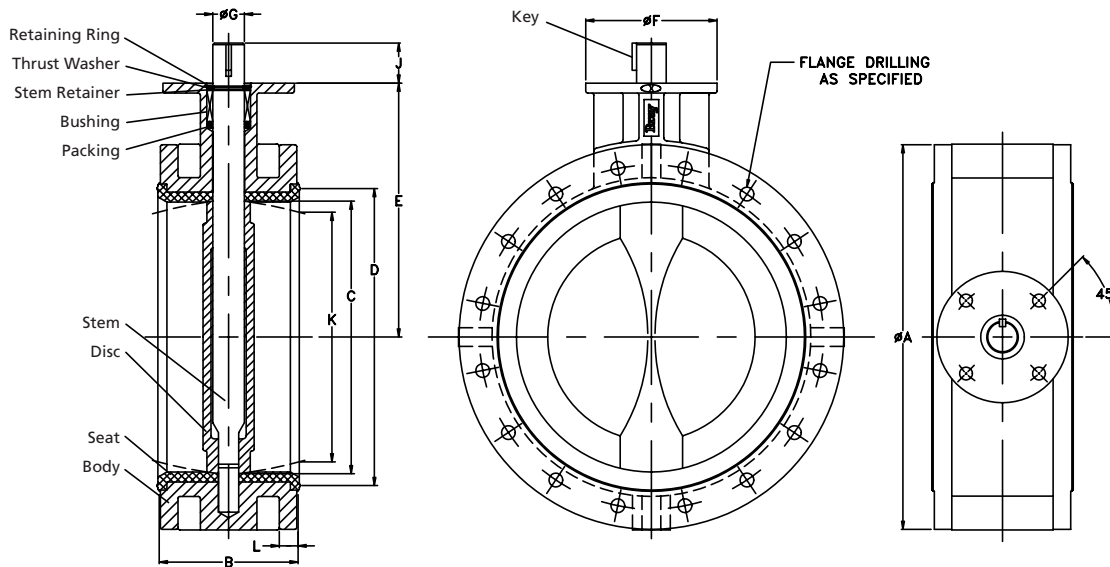

IMPERIAL DIMENSIONS: Inches																Flange Bolting Data			
Valve Size	A	B	C	D	E	F	Top Plate Drilling			G	Key Size	J	K	L	Adapter Code	Weight (lbs.)	Bolt Circle	No of Holes	Threads ISO Coarse
							BC	No of Holes	Hole Diameter										
14	21.00	7.48	13.25	15.28	13.62	5.91	4.92	4	.57	1.38	.39x.39	2.00	11.07	1.42	F	258	18.75	12	1-8
16	23.50	8.51	15.25	17.41	14.75	5.91	4.92	4	.57	1.38	.39x.39	2.00	12.81	1.50	F	318	21.25	16	1-8
18	25.20	8.74	17.25	19.47	16.00	8.27	6.50	4	.81	1.97	.47x.39	2.50	15.02	1.65	G	459	22.75	16	11/8-7
20	28.15	9.02	19.25	21.29	17.25	8.27	6.50	4	.81	1.97	.47x.39	2.50	17.15	1.65	G	534	25.00	20	11/8-7

Note: K dimension is disc chordal dimension at valve face.

METRIC DIMENSIONS: Millimeters																Flange Bolting Data			
Valve Size	A	B	C	D	E	F	Top Plate Drilling			G	H	J	K	L	Adapter Code	Weight (kg.)	Bolt Circle	No of Holes	Threads ISO Coarse
							BC	No of Holes	Hole Diameter										
350	533	190	337	388	346	150	125	4	14	35	10x10	51	281	36	F	117	476	12	1-8
400	597	216	387	442	375	150	125	4	14	35	10x10	51	325	38	F	144	540	16	1-8
450	640	222	438	495	406	210	165	4	21	50	12x10	64	381	42	G	208	578	16	11/8-7
500	715	229	489	548	438	210	165	4	21	50	12x10	64	436	42	G	242	635	20	11/8-7

Note: K dimension is disc chordal dimension at valve face.

Drawings are for reference only. Please refer to Bray ES drawings on the Bray website, www.bray.com. Bray reserves the right to change product dimensions without notice.

**SR Drawing #3A/3AH-14/20-in** January - 2015

Inquire/P.O. No.: \_\_\_\_\_

Customer/Project: \_\_\_\_\_

Bray Order No.: \_\_\_\_\_

**Series 31H Lug**

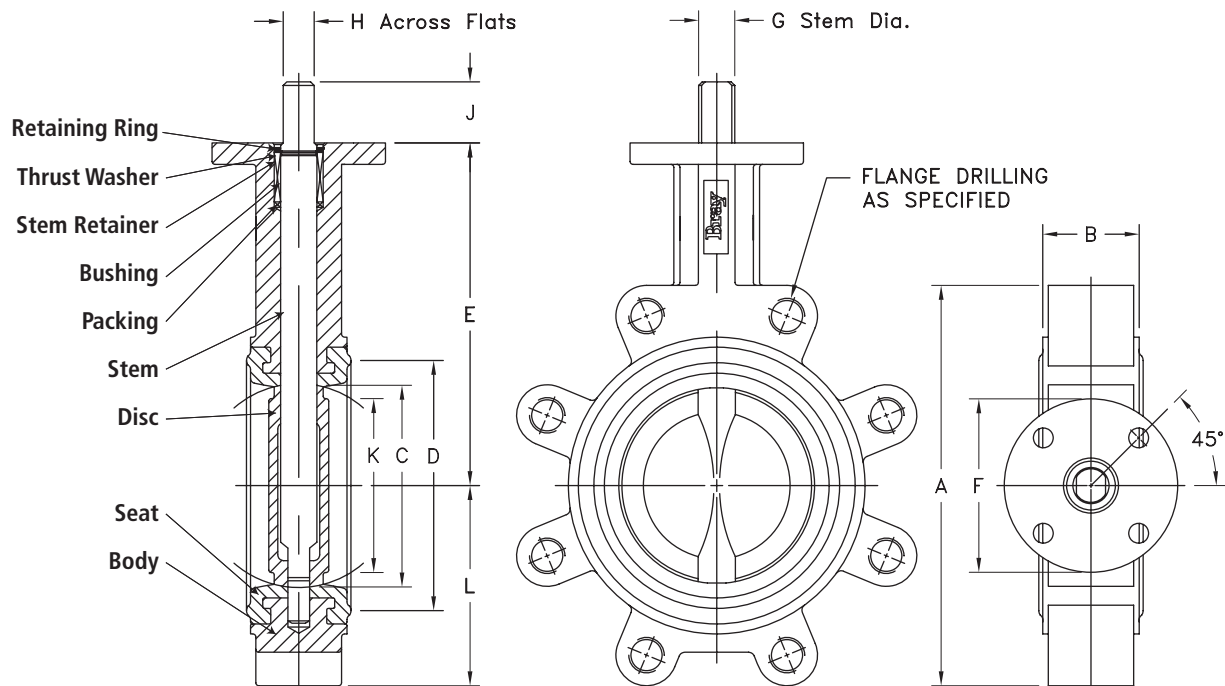

IMPERIAL DIMENSIONS: Inches															Lug Bolting Data				
Valve Size	A	B	C	D	E	F	Top Plate Drilling			G	H	J	K	L	Adapter Code	Weight (lbs)	Bolt Circle	No of Holes	Threads ISO Coarse
							BC	No of Holes	Hole Diameter										
2	3.69	1.62	2.00	2.84	5.50	3.54	2.76	4	.39	.55	.39	1.25	1.32	2.30	A	7.0	4.75	4	.62-11
2½	4.19	1.75	2.50	3.34	6.00	3.54	2.76	4	.39	.55	.39	1.25	1.91	2.57	A	8.0	5.50	4	.62-11
3	4.88	1.75	3.00	4.03	6.25	3.54	2.76	4	.39	.55	.39	1.25	2.55	2.81	A	9.0	6.00	4	.62-11
4	6.06	2.00	4.00	5.16	7.00	3.54	2.76	4	.39	.63	.43	1.25	3.57	4.09	B	15.0	7.50	8	.62-11
5	7.12	2.12	5.00	6.16	7.50	3.54	2.76	4	.39	.75	.51	1.25	4.63	4.61	C	20.0	8.50	8	.75-10
6	8.12	2.12	5.75	7.02	8.00	3.54	2.76	4	.39	.75	.51	1.25	5.45	5.06	C	23.0	9.50	8	.75-10
8	10.50	2.50	7.75	9.47	9.50	5.91	4.92	4	.57	.87	.63	1.25	7.45	6.05	D	42.0	11.75	8	.75-10
10	12.75	2.50	9.75	11.47	10.72	5.91	4.92	4	.57	1.18	.87	2.00	9.53	7.69	E	66.0	14.25	12	.88-9
12	14.88	3.00	11.75	13.47	12.25	5.91	4.92	4	.57	1.18	.87	2.00	11.47	9.02	E	88.0	17.00	12	.88-9

Note: K dimension is disc chordal dimension at valve face.

METRIC DIMENSIONS: Millimeters															Lug Bolting Data				
Valve Size	A	B	C	D	E	F	Top Plate Drilling			G	H	J	K	L	Adapter Code	Weight (Kg)	Bolt Circle	No of Holes	Threads ISO Coarse
							BC	No of Holes	Hole Diameter										
50	94	2	51	72	140	90	70	4	10	14	10	32	34	58	A	3	121	4	.62-11
65	106	2	64	85	152	90	70	4	10	14	10	32	49	65	A	3.6	140	4	.62-11
80	124	2	76	102	159	90	70	4	10	14	10	32	65	71	A	4.1	152	4	.62-11
100	154	2	102	131	178	90	70	4	10	16	11	32	91	104	B	7	191	8	.62-11
125	181	2	127	156	191	90	70	4	10	19	13	32	118	117	C	9	216	8	.75-10
150	206	2	146	178	203	90	70	4	10	19	13	32	138	129	C	10	241	8	.75-10
200	267	3	197	241	241	150	125	4	14	22	16	32	189	154	D	19	298	8	.75-10
250	324	3	248	291	272	150	125	4	14	30	22	51	242	195	E	30	362	12	.88-9
300	378	3	298	342	311	150	125	4	14	30	22	51	291	229	E	40	432	12	.88-9

Note: K dimension is disc chordal dimension at valve face.

Drawings are for reference only. Please refer to Bray ES drawings on the Bray website, www.bray.com. Bray reserves the right to change product dimensions without notice.

**SR Drawing #31H-2/12-im** January - 2015

Inquire/P.O. No.: \_\_\_\_\_

Customer/Project: \_\_\_\_\_

Bray Order No.: \_\_\_\_\_

**Series 31H Lug**

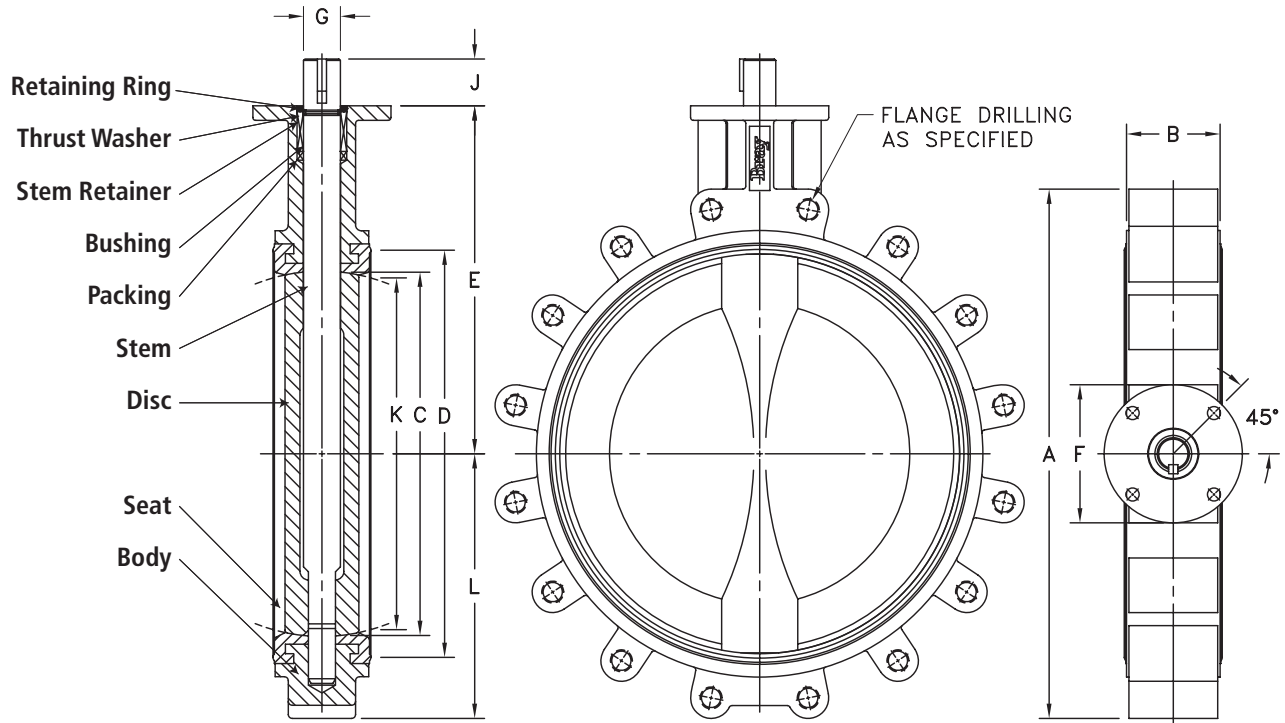

IMPERIAL DIMENSIONS: Inches																Lug Bolting Data			
Valve Size	A	B	C	D	E	F	Top Plate Drilling			G	J	Key Size	K	L	Adapter Code	Weight (lbs)	Bolt Circle	No of Holes	Threads ISO Coarse
							BC	No of Holes	Hole Diameter										
14	16.94	3.00	13.25	15.28	13.62	5.91	4.92	4	.57	1.38	2.00	.39x.39	13.04	9.93	F	114	18.75	12	1.00-8
16	19.06	4.00	15.25	17.41	14.75	5.91	4.92	4	.57	1.38	2.00	.39x.39	14.85	11.30	F	166	21.25	16	1.00-8
18	21.12	4.25	17.25	19.47	16.00	8.27	6.50	4	.81	1.97	2.50	.47x.39	16.85	12.16	G	226	22.75	16	1.12-7
20	23.25	5.00	19.25	21.59	17.25	8.27	6.50	4	.81	1.97	2.50	.47x.39	18.73	14.00	G	305	25.00	20	1.12-7

Note: K dimension is disc chordal dimension at valve face.

METRIC DIMENSIONS: Millimeters																Lug Bolting Data			
Valve Size	A	B	C	D	E	F	Top Plate Drilling			G	J	Key Size	K	L	Adapter Code	Weight (Kg)	Bolt Circle	No of Holes	Threads ISO Coarse
							BC	No of Holes	Hole Diameter										
350	430	76	337	388	346	150	125	4	14	35	51	10x10	331	252	F	52	476	12	1.00-8
400	484	102	387	442	375	150	125	4	14	35	51	10x10	377	287	F	75	540	16	1.00-8
450	536	108	438	495	406	210	165	4	21	50	64	12x10	428	309	G	103	578	16	1.12-7
500	591	127	489	548	438	210	165	4	21	50	64	12x10	476	356	G	138	635	20	1.12-7

Note: K dimension is disc chordal dimension at valve face.

Drawings are for reference only. Please refer to Bray ES drawings on the Bray website, www.bray.com. Bray reserves the right to change product dimensions without notice.

**SR Drawing #31H-14/20-im** January - 2015

Inquire/P.O. No.: \_\_\_\_\_

Customer/Project: \_\_\_\_\_

Bray Order No.: \_\_\_\_\_

**Series 35-36 Double Flange**

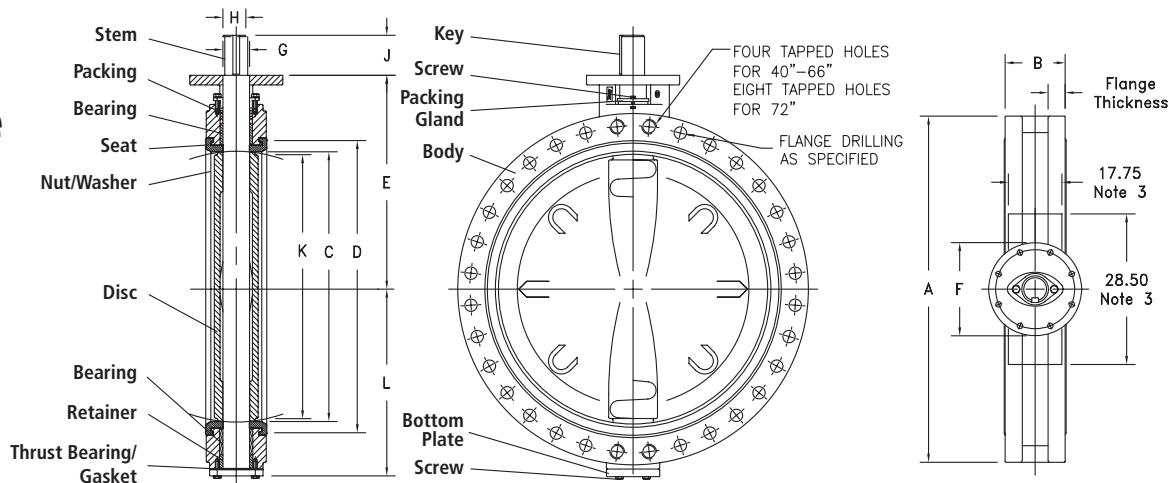

- NOTES:  
 1. K dimension is disc cordial dimension of valve face.  
 2. \* Denotes preliminary dimensions.  
 3. These dimensions apply ONLY to the size 72".

IMPERIAL DIMENSIONS: Inches		ANSI Class 125/150 Valves																		
Valve Size Ins	A	B	C	D	E	F	Mounting Flange Drilling			G	SERIES 35				SERIES 36				L	Weight (lbs.)
							PCD	No. Holes	Hole Dia.		H	J	Key Size	K	H	J	Key Size	K		
22	31.25	6.06	21.27	24.12	20.12	8.27	6.50	4	.81	2.50	2.50	4.00	.62x.62	20.51	2.50	4.00	.62x.62	20.56	16.56	475
24	33.00	5.94	23.28	25.75	19.50	8.27	6.50	4	.81	2.50	2.50	4.00	.62x.62	22.65	2.50	4.00	.62x.62	22.70	17.56	500
26	35.25	6.50	24.46	27.83	21.83	11.81	10.00	8	.71	2.50	2.50	4.00	.62x.62	23.71	2.50	4.00	.62x.62	23.76	18.82	675
28	37.80	6.50	26.46	29.83	22.84	11.81	10.00	8	.71	2.50	2.50	4.00	.62x.62	25.74	2.50	4.00	.62x.62	25.79	19.83	735
30	38.75	6.56	29.29	32.14	23.00	11.81	10.00	8	.71	3.00	2.50	4.00	.62x.62	28.68	3.00	4.00	.75x.75	28.73	20.81	855
32	41.75	7.48	30.39	33.78	26.38	11.81	10.00	8	.71	3.00	2.50	4.00	.62x.62	29.59	3.00	4.00	.75x.75	29.64	21.94	1010
34	44.69	7.88	33.00	35.82	26.93	13.78	11.73	8	.81	3.50	3.00	4.00	.75x.75	32.18	3.50	5.25	.88x.62	32.23	23.66	1165
36	46.00	7.88	35.30	38.25	27.75	13.78	11.73	8	.81	3.50	3.00	4.00	.75x.75	34.57	3.50	5.25	.88x.62	34.62	24.94	1320
40	50.75	8.50	38.27	41.66	30.79	13.78	11.73	8	.81	4.00	3.50	5.25	.88x.62	37.44	4.00	5.25	1.0x.75	37.49	26.56	2140
42	53.00	9.88	41.25	44.62	32.00	13.78	11.73	8	.81	4.00	3.50	5.25	.88x.62	40.21	4.00	5.25	1.0x.75	40.26	27.81	2550
44	55.25	9.88	43.25	46.72	33.12	13.78	11.73	8	.81	4.00	3.50	5.25	.88x.62	42.24	4.00	5.25	1.0x.75	42.29	29.06	2800
48	59.50	10.88	47.25	50.62	36.00	16.34	14.02	8	1.28	5.00	4.00	5.25	1.0x.75	46.16	5.00	6.00	1.25x.88	46.21	31.06	3200
52	Consult Factory																			
54	69.00	15.00	54.00	57.50	40.62	13.78	11.73	8	.81	6.00	5.00	5.25	1.25x.88	52.02	—	—	—	—	37.25	6000
54	69.00	15.00	54.00	57.50	40.62	16.34	14.02	8	1.28	6.00	—	—	—	—	6.00	6.50	1.5x1.0	52.06	37.25	6000
56	Consult Factory																			
60	73.00	15.00	58.39	63.07	44.31	16.34	14.02	8	1.38	7.00	6.00	6.50	1.5x1.0	56.67	—	—	—	—	39.12	7000
60	73.00	15.00	58.39	63.07	44.31	18.70	15.98	8	1.56	7.00	—	—	—	—	7.00	7.50	1.75x1.5	56.72	39.12	7000
64	Consult Factory																			
66	80.00	18.00	65.12	70.04	48.75	16.34	14.02	8	1.38	7.00	6.00	6.50	1.5x1.0	62.84	—	—	—	—	43.80	8000
66	80.00	18.00	65.12	70.04	48.75	18.70	15.98	8	1.56	7.00	—	—	—	—	7.00	7.50	1.75x1.5	62.88	43.80	8000
72	86.50	18.00	69.22	73.90	52.25	22.05	15.98	8	1.56	8.50	7.50	8.00	1.75x1.5	67.06	—	—	—	—	46.92	11250
72	86.50	18.00	69.22	73.90	52.25	22.05	19.02	12	1.56	8.50	—	—	—	—	8.50	10.00	2.0x1.5	67.10	46.92	11250
78	93.00	18.00	76.37	81.29	55.00	27.00	19.02	12	1.31	8.50	7.50	8.00	1.75x1.5	74.49	—	—	—	—	51.28	12950
78	93.00	18.00	76.37	81.29	55.00	27.00	19.02	12	1.56	8.50	—	—	—	—	8.50	8.50	2.0x1.5	74.54	51.28	12950
84	99.76	18.00	82.62	87.54	58.88	27.00	23.74	20	1.31	9.50	8.50	8.50	2.0x1.5	80.91	—	—	—	—	55.66	14500
84	99.76	18.00	82.62	87.54	58.88	27.00	23.74	20	1.56	9.50	—	—	—	—	9.50	10.00	2.5x1.75	80.96	55.66	14500
90	Consult Factory																			
96	Consult Factory																			

Drawings are for reference only. Please refer to Bray ES drawings on the Bray website, www.bray.com. Bray reserves the right to change product dimensions without notice.

**SR Drawing #35/36-22/96-in** January - 2015

Inquire/P.O. No.: \_\_\_\_\_

Customer/Project: \_\_\_\_\_

Bray Order No.: \_\_\_\_\_

**Series 35-36 Double Flange**

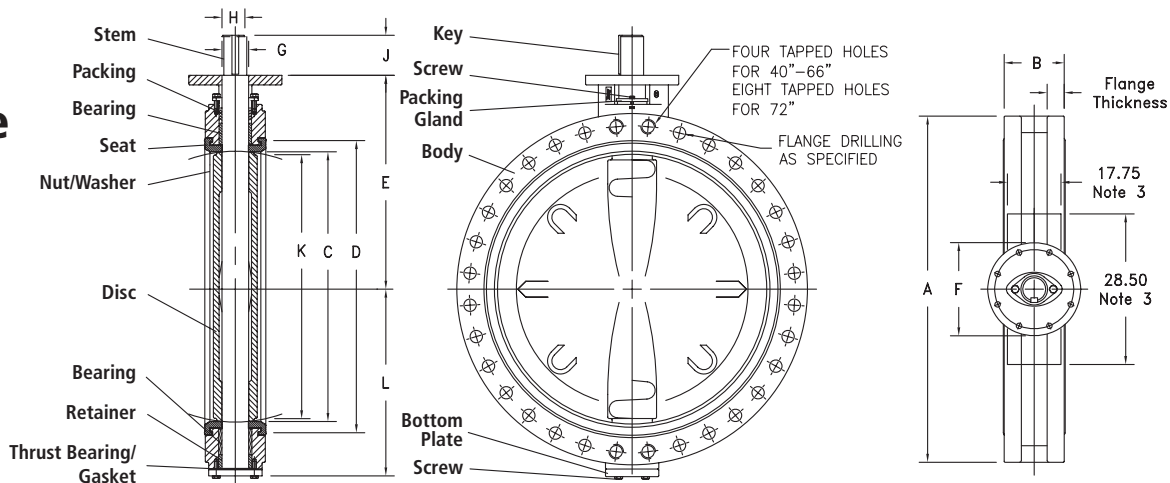

- NOTES:  
 1. K dimension is disc cordial dimension of valve face.  
 2. \* Denotes preliminary dimensions.  
 3. These dimensions apply ONLY to the size 72".

**METRIC DIMENSIONS: Millimeters ANSI Class 125/150 Valves**

Valve Size mm							Mounting Flange Drilling			SERIES 35					SERIES 36					Weight (kg)
	A	B	C	D	E	F	PCD	No. Holes	Hole Dia.	G	H	J	Key Size	K	H	J	Key Size	K	L	
550	794	154	540	613	511	210	165	4	21	64	64	102	16 x 16	521	64	102	16 x 16	9	421	215
600	838	151	591	654	495	210	165	4	21	64	64	102	16 x 16	575	64	102	16 x 16	10	446	227
650	895	165	621	707	554	300	254	8	18	64	64	102	16 x 16	602	64	102	16 x 16	11	478	306
700	960	165	672	758	580	300	254	8	18	64	64	102	16 x 16	654	64	102	16 x 16	12	504	333
750	984	167	744	816	584	300	254	8	18	76	64	102	16 x 16	728	76	102	19 x 19	13	529	388
800	1060	190	772	858	670	300	254	8	18	76	64	102	16 x 16	752	76	102	19 x 19	13	557	458
850	1135	200	838	910	684	350	298	8	21	89	76	102	19 x 19	817	89	133	22 x 16	818	601	528
900	1168	200	897	972	705	350	298	8	21	89	76	102	19 x 19	878	89	133	22 x 16	879	633	599
1000	1289	216	972	1058	782	350	298	8	21	102	89	133	22 x 16	951	102	133	25 x 19	952	675	971
1050	1346	251	1048	1133	813	350	298	8	21	102	89	133	22 x 16	1021	102	133	25 x 19	1022	706	1157
1100	1403	251	1099	1187	841	350	298	8	21	102	89	133	22 x 16	1073	102	133	25 x 19	1074	738	1270
1200	1511	276	1200	1286	914	415	356	8	33	127	102	133	25 x 19	1172	127	152	32 x 22	1174	789	1451
1300	CONSULT FACTORY																			
1350	1753	381	1372	1461	1032	350	298	8	21	152	127	133	32 x 22	1321	—	—	—	—	946	2722
1350	1753	381	1372	1461	1032	415	356	8	33	152	—	—	—	—	152	165	38 x 25	1322	946	2722
1400	CONSULT FACTORY																			
1500	1854	381	1483	1602	1125	415	356	8	35	178	152	165	38 x 25	1439	—	—	—	—	994	3175
1500	1854	381	1483	1602	1125	475	406	8	40	178	—	—	—	—	178	191	45 x 38	1441	994	3175
1600	CONSULT FACTORY																			
1650	2032	457	1654	1779	1238	415	356	8	35	178	152	165	39 x 25	1596	—	—	—	—	1113	3629
1650	2032	457	1654	1779	1238	475	406	8	40	178	—	—	—	—	178	191	45 x 38	1597	1113	3629
1800	2197	457	1758	1877	1327	560	406	8	40	216	191	203	45 x 38	1703	—	—	—	—	1192	5103
1800	2197	457	1758	1877	1327	560	483	12	40	216	—	—	—	—	216	254	51 x 38	1704	1192	5103
2000	2362	457	1940	2065	1397	686	483	12	33	216	191	203	45 x 38	1892	—	—	—	—	1303	5874
2000	2362	457	1940	2065	1397	686	483	12	40	216	—	—	—	—	216	216	51 x 38	1893	1303	5874
2100	2534	457	2099	2224	1496	686	603	20	33	241	216	216	51 x 38	2055	—	—	—	—	1414	6577
2100	2534	457	2099	2224	1496	686	603	20	40	241	—	—	—	—	241	254	64 x 45	2056	1414	6577
2200	CONSULT FACTORY																			
2400	CONSULT FACTORY																			

Drawings are for reference only. Please refer to Bray ES drawings on the Bray website, www.bray.com. Bray reserves the right to change product dimensions without notice.

**SR Drawing #35/36-22/96-m** January - 2015

Inquire/P.O. No.: \_\_\_\_\_

Customer/Project: \_\_\_\_\_

Bray Order No.: \_\_\_\_\_

**Series 35F Double Flange**

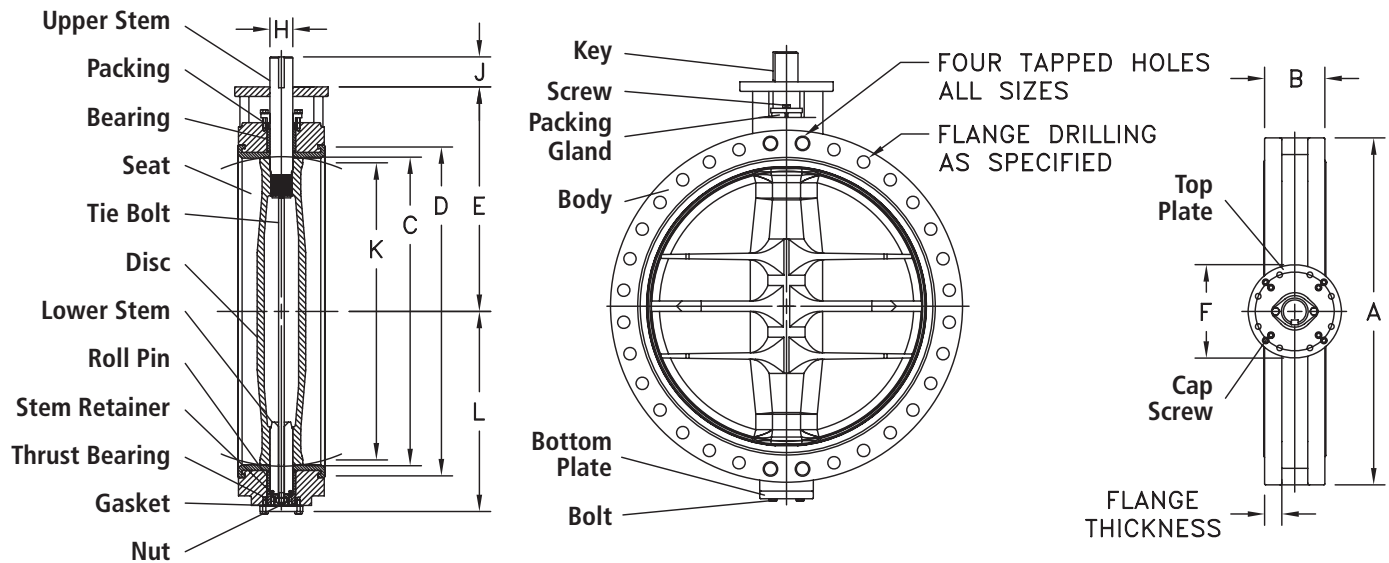

**IMPERIAL DIMENSIONS: Inches**

Valve Size	A	B	Flange Thk.	C	D	E	F	Top Plate Drilling			H	J	Key Size	K	L	Adapter Code	Weight (lbs)
								BC	No of Holes	Hole Diameter							
32	41.75	7.48	2.00	30.39	33.70	26.37	11.81	10.00	8	.71	2.50	4.00	.62 x .62	29.57	21.88	F25-1	972
36	46.00	7.88	2.00	33.50	38.25	27.75	13.78	11.73	8	.81	2.50	4.00	.62 x .62	34.50	23.60	TBA	1079
40	50.75	8.50	1.97	38.37	41.58	30.78	13.78	11.73	8	.81	3.00	4.00	.75 x .75	37.45	26.56	F30-1	1945
42	53.00	9.88	2.62	41.25	44.25	32.00	13.78	11.73	8	.81	3.00	4.00	.75 x .75	40.20	27.81	F30-1	2282
44	55.25	9.88	2.62	43.25	46.25	33.12	13.78	11.73	8	.81	3.50	5.25	.88 x .62	42.20	29.06	F30-2	2520
48	59.50	10.88	2.75	47.25	50.62	36.00	16.34	14.02	8	1.30	3.50	5.25	.88 x .62	46.13	31.06	TBA	2880
54	69.00	15.36	3.00	54.12	57.50	40.62	13.78	11.73	8	.81	4.00	5.25	1.00 x .75	51.88	37.19	F30-3	5290
60	73.00	15.00	3.12	58.39	63.07	44.31	16.34	14.02	8	1.56	5.00	6.00	1.25 x .88	56.62	39.56	F30-4	5671

Note: K dimension is disc chordal dimension at valve face.

**Metric DIMENSIONS: Millimeters**

Valve Size	A	B	Flange Thk.	C	D	E	F	Top Plate Drilling			H	J	Key Size	K	L	Adapter Code	Weight (kg)
								BC	No of Holes	Hole Diameter							
800	1060	190	51	772	856	670	300	254	8	18	64	102	16 x 16	751	556	F25-1	441
900	1168	200	51	851	972	705	350	298	8	21	64	102	16 x 16	876	599	TBA	489
1000	1289	216	50	975	1056	782	350	298	8	21	76	102	19 x 19	951	675	F30-1	882
1050	1346	251	67	1048	1124	813	350	298	8	21	76	102	19 x 19	1021	706	F30-1	1035
1100	1403	251	67	1099	1175	841	350	298	8	21	89	133	22 x 16	1072	738	F30-2	1143
1200	1511	276	70	1200	1286	914	415	356	8	33	89	133	22 x 16	1172	789	TBA	1306
1400	1753	390	76	1375	1461	1032	350	298	8	21	102	133	25 x 19	1318	945	F30-3	2400
1500	1854	381	79	1483	1602	1125	415	356	8	40	127	152	32 x 22	1438	1005	F30-4	2572

Note: K dimension is disc chordal dimension at valve face.

Drawings are for reference only. Please refer to Bray ES drawings on the Bray website, www.bray.com. Bray reserves the right to change product dimensions without notice.

**SR Drawing #35F-32/60-im** January - 2015

Inquire/P.O. No.: \_\_\_\_\_

Customer/Project: \_\_\_\_\_

Bray Order No.: \_\_\_\_\_