

# **Bray** McCannalok<sup>®</sup>

## **HIGH PERFORMANCE BUTTERFLY VALVE**

### *OPERATION AND MAINTENANCE MANUAL*

---

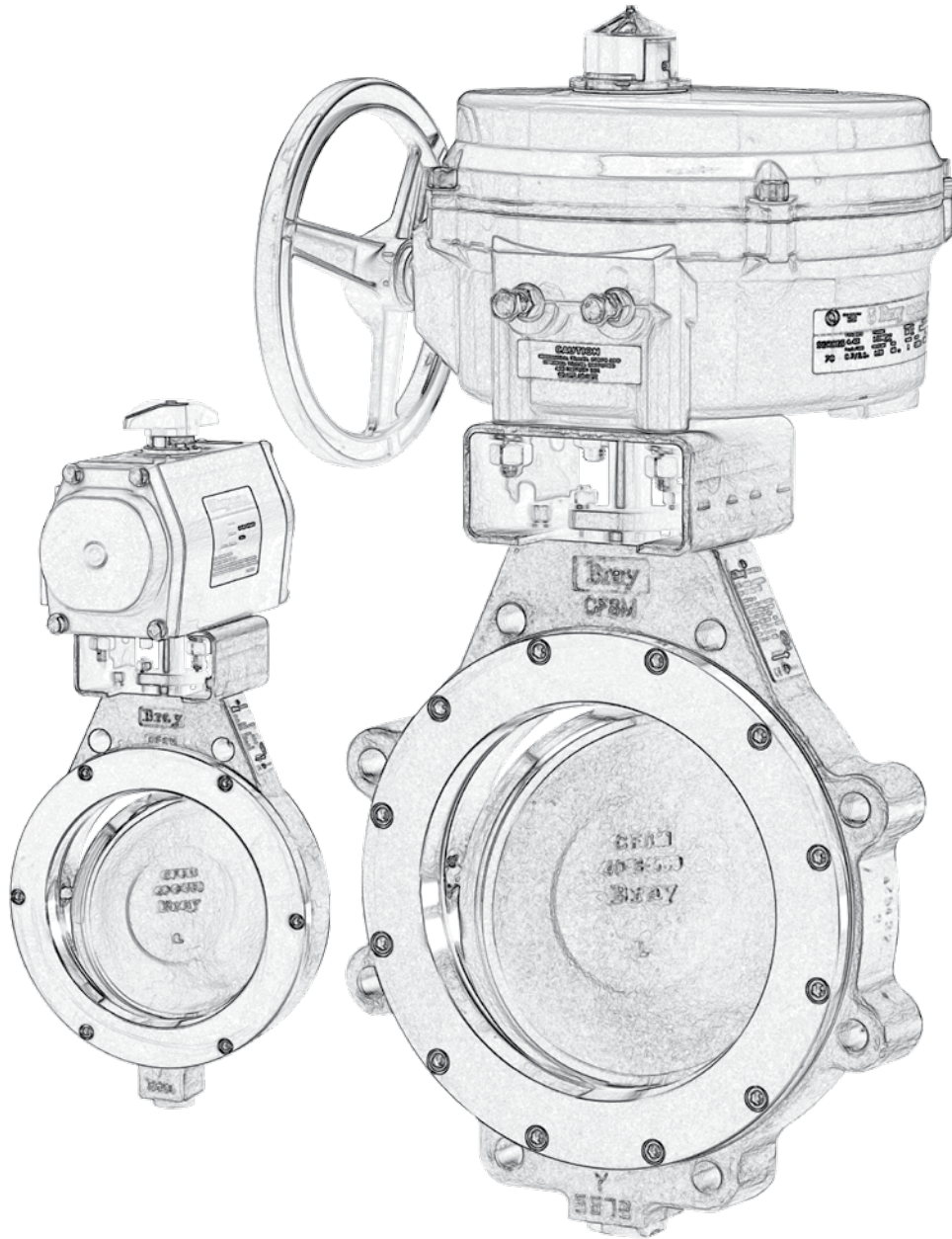

# TABLE OF CONTENTS

SAFETY INFORMATION - DEFINITION OF TERMS .....	I
INTRODUCTION .....	I
INSTALLATION .....	I
MAINTENANCE .....	2
STEM SEAL REPLACEMENT .....	4
SEAT REPLACEMENT .....	4
DISC AND STEM REPLACEMENT .....	5
PARTS DIAGRAM .....	7
SPECIAL INSTRUCTIONS - FIRE SAFE BRAY/McCANNALOK INSTALLATION .....	8
SEAT REPLACEMENT .....	8
STEM SEAL REPLACEMENT .....	8
STEM AND DISC REPLACEMENT .....	9
FIELD ADJUSTMENTS .....	9

## SAFETY INFORMATION - DEFINITION OF TERMS



### WARNING

indicates a potentially hazardous situation which, if not avoided, **could** result in death or serious injury.



### CAUTION

indicates a potentially hazardous situation which, if not avoided, may result in minor or moderate injury.

### NOTICE

used without the safety alert symbol indicates a potential situation which, if not avoided, may result in an undesirable result or state, including property damage.

## Introduction

The Bray/McCannalok high-performance butterfly valve combines the advantages of trunnion-type ball valves with the easy operation, light weight, and low cost of butterfly valves. One basic design is suitable for a wide range of services, including oxygen, chlorine, sour gas, vacuum, and steam applications.

### Features Include:

- Bubbletight shutoff provided throughout a wide range of operating conditions.
- Suitable for both modulating and on/off services, the Bray/McCannalok butterfly valve is easily automated with your choice of manual operators, electric and pneumatic actuators, positioners, and controls.
- The Bray/McCannalok is available in a Fire Safe model qualified to API 607 5th Edition and BS 6755 part 2.

**Additional information about Bray/McCannalok butterfly valves – including application data, engineering specifications, and actuator selection is available from your Bray distributor or sales representative.**

## Installation

Special instructions for Fire Safe valves appear on **page 8**.

1. The Bray/McCannalok valve is designed to be mounted between ANSI flanges. When the valve is open, the disc will extend into the pipe on both sides of the valve – further on the body side than the seat retainer side of the valve. Piping must be large enough to allow the disc to clear the pipe. The charts on **page 2** show the minimum pipe ID allowable, and standard pipe IDs. In general, Class 150 valves will clear Schedule 40 pipe, and Class 300 valves will clear Schedule 80 pipe adequately. Class 600 will in general clear Schedule 80 sizes 3, 4, and 6; and Schedule 100 in sizes 8, 10, 12, 14, and 16.



### CAUTION

2. If handle or actuator has been removed do not rotate disc beyond full open or closed position – this could cause damage to sealing surfaces.

**NOTE:** Bray/McCannalok valves are equipped with travel limiters to prevent over closure. The valve is opened by turning counterclockwise, closed by turning clockwise. The double “D” flats or keyway at the top of the stem is parallel to the disc edge.

### NOTICE

3. For maximum service life, install the valve with the seat retainer upstream.

Positive shutoff will be obtained with the valve in either position; however, installation with the seat retainer upstream will give longer service life, especially in erosive services.

4. With the disc in closed position, carefully center valve between flanges. Guide holes (wafer pattern valve) or tapped holes (lugged valves) to match ANSI Pipe flanges and assist in positive alignment.
5. Use standard torques when bolting valve into the line. The seat is sufficiently compressed by the seat retainer, and additional force from flange bolting is not required.

6. Gaskets should conform to the requirements of API Standard 601, Edition 3 for ASME/ANSI B16.5 class flanges. Spiral wound gaskets, such as Flexitallic CG or CGI series, conforming to ASME/ANSI B16.20 are acceptable.

## Maintenance

1. Reasonable precautions should be taken before beginning work on the valve. Protective clothing, as required by the specific line fluid, should be worn.



### WARNING

2. Before removing handle or the actuator from the valve, or before removing seat retainer from a valve in dead end service, close the valve and depressurize the line.

The eccentric design of the Bray/McCannalok may allow line pressure to open the valve if the handle/actuator is not in place while the valve is under pressure.

### NOMINAL INSIDE DIAMETER OF PIPE

Valve Size	Schedule		
	40	80	100
2.5 (65)	2.469 (62.713)	2.323 (59.004)	
3 (80)	3.068 (77.927)	2.900 (73.660)	
4 (100)	4.026 (102.260)	3.826 (97.180)	
5 (125)	5.047 (128.194)	4.813 (122.250)	
6 (150)	6.065 (154.051)	5.761 (146.329)	
8 (200)	7.981 (202.717)	7.625 (193.675)	7.439 (188.951)
10 (250)	10.020 (254.508)	9.564 (242.926)	9.314 (236.576)
12 (300)	11.938 (303.225)	11.376 (288.950)	11.064 (281.026)
14 (350)	13.124 (333.350)	12.500 (317.500)	12.126 (308.000)
16 (400)	15.000 (381.000)	14.314 (363.576)	13.938 (354.025)
18 (450)	16.876 (428.650)	16.126 (409.600)	
20 (500)	18.814 (477.876)	17.938 (455.625)	
24 (600)	22.626 (574.700)	21.564 (547.726)	



### WARNING

Do not pressurize the line without a handle or actuator on the valve.

3. The Bray/McCannalok valve must be in the closed position to be removed from the line.
4. Begin all work on a valve that has been removed from the line by cleaning the valve, removing any grit or scale.

### MINIMUM INSIDE DIAMETER OF PIPE WITH THE RECOMMENDED CLEARANCE

Valve Size	Class		
	150	300	600
2.5 (65)	2.28 (57.91)	2.28 (57.91)	
3 (80)	2.86 (72.64)	2.86 (72.64)	2.75 (69.85)
4 (100)	3.72 (94.49)	3.72 (94.49)	3.56 (90.42)
5 (125)	4.80 (121.92)	4.80 (121.92)	
6 (150)	5.88 (149.35)	5.75 (146.05)	5.38 (136.65)
8 (200)	7.80 (198.12)	7.56 (192.02)	6.88 (174.75)
10 (250)	9.78 (248.41)	9.44 (239.78)	8.50 (215.90)
12 (300)	11.74 (298.20)	11.31 (287.27)	10.12 (257.05)
14 (350)	12.90 (327.66)	11.38 (289.05)	10.88 (276.35)
16 (400)	14.68 (372.87)	14.31 (363.47)	12.62 (320.55)
18 (450)			14.40 (365.76)
20 (500)			15.86 (402.84)
24 (600)	22.50 (571.50)	20.68 (525.27)	
30 (750)	28.55 (725.17)	27.06 (687.32)	
32 (800)	30.69 (779.53)		
36 (900)	34.50 (876.30)	33.63 (854.20)	
40 (1000)	37.55 (953.77)	36.59 (929.39)	
42 (1050)	39.55 (1004.57)	38.67 (982.22)	
44 (1100)		38.67 (982.22)	
48 (1200)	51.09 (1297.69)	45.13 (1146.30)	
54 (1350)	52.95 (1344.93)		
60 (1500)	58.25 (1479.55)		



**CAUTION**

When handling the valve, care should be taken not to scratch the disc edge or seat.

6. Replacement seats, seals and other parts are available from authorized distributors. Contact your distributor or sales representative for details of price and delivery.

**NOTES:**

1. Minimum I.D. of pipe with recommended clearances (per API 609) have been calculated by adding the minimum I.D. with zero clearance to a minimum recommended diametric clearance for each pipe size.
2. These charts assume that the pipe is on the body side of the valve and that the pipe is perfectly centered. The seat retainer side of the valve will always have more clearance than the body side.
3. A minimum of 1/16" thick gasket is used between the pipe flange and valve body face.
4. When using a pipe whose I.D. is smaller than the recommended minimum inside diameter of pipe with adequate clearance, a chamfer of 45° should be provided on the end of the pipe so that it clears the disc.

## Stem Seal Replacement

Refer to drawing on **page 7** for parts identification

1. If required, remove handle assembly. Remove socket head cap screws (21) and lock washers (22). Remove mounting bracket (20). For actuated valves, unbolt mounting bracket from body and lift actuator assembly off stem.

### NOTICE

Note assembly positions before removal.

2. Remove gland retainer nuts (14) and lock washers (13). Remove gland retainer (11) anti-blowout retaining ring or split ring (10) (depending on size), and gland ring (7).
3. Hook out stem seals (8).



### CAUTION

When handling stem seals, care should be taken not to scratch stem or stuffing box bore.

Do not remove thrust washer (9), unless further valve disassembly is required.

4. Examine stuffing box bore and stem, clean as necessary to remove any corrosion or foreign matter before installing new seals.
5. Install new seals in stuffing box one at a time, TFE (white) seals first, with the carbon fiber ring at the top. Stagger seal

**TABLE 1**

**TOTAL NUMBER OF STEM SEALS**

Valve Size		Class 150	Material CF / TFE	Class 300	Material CF/TFE	Class 600	Material CF / TFE
Ins	(mm)						
2.5	(65)	4	1 / 3	4	1 / 3		
3	(80)	4	1 / 3	4	1 / 3	12	2 / 10
4	(100)	4	1 / 3	4	1 / 3	12	2 / 10
5	(125)	4	1 / 3	4	1 / 3		
6	(150)	4	1 / 3	4	1 / 3	16	2 / 14
8	(200)	5	1 / 4	5	1 / 4	16	2 / 14
10	(250)	5	1 / 4	5	1 / 4	18	0 / 18
12	(300)	5	1 / 4	5	1 / 4	18	0 / 18
14	(350)	6	0 / 6	6	0 / 6	18	0 / 18
16	(400)	6	0 / 6	9	0 / 9	16	0 / 16
18	(450)					16	0 / 16
20	(500)					16	0 / 16
24	(600)	10	0 / 10	8	0 / 8		
30	(750)	8	0 / 8	9	0 / 9		
32	(800)	8	0 / 8				
36	(900)	8	0 / 8	9	0 / 9		
40	(1000)	9	0 / 9	9	0 / 9		
42	(1050)	9	0 / 9	9	0 / 9		
44	(1100)			9	0 / 9		
48	(1200)	9	0 / 9	9	0 / 9		
54	(1350)	9	0 / 9				
60	(1500)	9	0 / 9				

CF = Carbon Fiber

ring joints 180° apart when installing. Tamp each ring to bottom before installing next ring.

### NOTICE

On the larger valves it will be necessary to compress each seal before adding the next.

6. Slide gland ring (7) over stem on top of seals (8). Install anti-blowout retaining ring or split ring (10) (depending on valve size). Slide gland retainer (11) over stem and onto gland studs (12). Place lockwashers (13) and hex nuts (14) on studs (12) and tighten finger tight. Tighten gland nuts (14) evenly and alternately to the proper torque value given in **Table 2 (pg. 5)**.
7. Remount actuator, or mounting bracket (20) with lock washers (22) and cap screws (21) and handle assembly.
8. Operate valve open and closed several times to check for binding and to set the stem seals. Loosen gland nuts (14) and retighten to torque value given in **Table 2 (pg. 5)**.

## Seat Replacement

Refer to drawing on **page 7** for parts identification. With the disc in the closed position, remove the valve from the line.

1. Lay the valve down with the disc in the closed position and the seat retainer side facing up.
2. Remove the socket head cap screws (17), the seat retainer (16), and seat (15).
3. Carefully clean the seat area in the body and seat retainer. Remove foreign matter, dirt, etc. Check disc seating area for nicks or scratches.
4. Place the new seat (15) on disc (2), carefully centering it in the recess in the body.
5. Align the holes in the seat retainer (16) with matching holes in body and carefully place in position on top of seat (15).



### CAUTION

Do not shift the retainer in order to align holes. It may shift the seat from its correct position.

Lightly grease cap screw (17) threads and tighten down evenly, alternating from top to bottom and side to side. Tighten to the torque values in **Table 2 (pg. 5)**.

6. Operate valve several times and examine seat for any damage before reinstalling the valve in the line.

**TABLE 2**  
**GLAND RETAINER NUT AND SEAT RETAINER**  
**SCREW TORQUES. - In-lbf (N·m)**

Valve Size Ins (mm)	Gland Nut			Seat Retainer Screws		
	150	300	600	150	300	600
2.5 (65)	60 (7)	60 (7)		100 (11)	100 (11)	
3 (80)	60 (7)	60 (7)	80 (9)	100 (11)	100 (11)	100 (11)
4 (100)	60 (7)	60 (7)	100 (11)	175 (20)	175 (20)	175 (20)
5 (125)	80 (9)	100 (11)		100 (11)	175 (20)	
6 (150)	80 (9)	120 (14)	140 (16)	100 (11)	175 (20)	300 (34)
8 (200)	80 (9)	140 (16)	200 (23)	175 (20)	175 (20)	300 (34)
10 (250)	110 (12)	190 (21)	200 (23)	175 (20)	300 (34)	300 (34)
12 (300)	130 (15)	220 (25)	200 (23)	300 (34)	300 (34)	300 (34)
14 (350)	130 (15)	200 (23)	240 (27)	300 (34)	300 (34)	500 (56)
16 (400)	150 (17)	220 (25)	240 (27)	300 (34)	300 (34)	750 (85)
18 (450)			400 (45)			1500 (169)
20 (500)			480 (54)			1500 (169)
24 (600)	190 (21)	240 (27)		500 (56)	500 (56)	
30 (750)	210 (24)	310 (35)		500 (56)	750 (85)	
32 (800)	210 (24)			750 (85)		
36 (900)	240 (27)	360 (41)		500 (56)	1500 (169)	
40 (1000)	280 (32)	420 (47)		500 (56)	1500 (169)	
42 (1050)	280 (32)	420 (47)		500 (56)	1500 (169)	
44 (1100)		420 (47)			1500 (169)	
48 (1200)	300 (34)	600 (68)		750 (85)	1500 (169)	
54 (1350)	360 (41)				1500 (169)	
60 (1500)	500 (56)				1500 (169)	

## Disc and Stem Replacement

Refer to drawing on page 7 for parts identification.

### NOTICE

Stem and disc are supplied as a matched set with taper pins and are to be replaced as a set.

- For handle-operated valves remove handle assembly. Remove socket head cap screws (21) and lock washers (22). Remove mounting bracket (20). For actuated valves, unbolt mounting bracket from body and lift actuator assembly off stem.

### NOTICE

Note assembly positions before removal.

- Remove gland retainer nuts (14) and lock washers (13). Remove gland retainer (11), anti-blowout retaining ring or split ring (10) (depending on valve size), and gland ring (7).
- Hook out stem seals (8).



### CAUTION

Take care not to scratch stem or stuffing box bore.

- Remove locating plug (19) and gasket (18).
- Remove cap screws (17), seat retainer (16), and seat (15).
- Turn disc to the full open position and drill out tack welds on large end of taper pins (4).



### CAUTION

Take care to support valve so that disc surfaces are not scratched.

Drill sizes to remove tack welds as given in **Table 3 on page 6**. Use center-punch to dimple center of tack welds prior to drilling.

- Place valve in flat position, with flat face of disc up. Support disc and body on wooden blocks to protect disc and body surfaces. Disc will rest in partially open position.
- Knock out taper pins (4) using a rod or punch on small end of pin (opposite tack weld). It may be necessary

to lift body and rotate disc slightly to do this. Make sure disc is resting on wood block since it will swing freely on stem with pins removed. When pins (4) are out, lay body down so disc and body are evenly supported on flat surface.

9. Using a brass bar or drift punch, knock stem (3) loose and pull from body. After long or severe service this may take considerable force. Be careful not to damage bearings, spacers or body.



**CAUTION**

Be careful not to damage bearings, spacers or body.

Disc spacers (5) are used at top and bottom of disc to properly position disc in body. Proper spacers were selected at initial assembly and rarely require replacement. The location of these spacers should be noted, and the spacers marked at disassembly so that they are reinstalled in the same positions, top and bottom.

10. Separate body from disc, and remove thrust washer (9) from packing bore.
11. Examine stem bearings (6) for excessive wear. If removed from body,

**NOTICE**

Note position and mark to reinstall in same location.

Replacement is rarely needed, however, if bearing liner is worn through to the shell, or severe damage is evident they should be replaced.

12. Clean body thoroughly to remove all dirt, foreign matter, rust, etc.
13. Place the body (1) flat, seat retainer side up, and support it on wooden blocks sufficiently above the work surface as to facilitate insertion of the disc (2) in open position. Lower the disc into position, aligning the bores in body and disc.
14. Insert new stem (3) in body (1) with large end of the taper pin holes toward the top. Assemble disc spacers (5) as stem (3) is inserted, making sure that spacers are returned to original locations as marked.
15. Align taper pin holes in disc and stem, and install taper pins (4). Drive pins in tightly with rod or punch, and tack weld each pin (4) to disc (2) at large end of pin.
16. Install new gasket (18) on locating plug (19) and install plug in body.

17. Install new stem seals, following instructions in “Stem Seal Replacement” section. (see pg. 4)
18. Install new seat, following instructions in “Seat Replacement” section. (see pg. 4)
19. Remount handle assembly or actuator, and operate valve several times to verify proper operation. Examine disc and seat for any damage before reinstalling in line.

**TABLE 3**

**DRILL SIZE TO REMOVE TACK WELD - In. (mm)**

Valve Size Ins (mm)	Class					
	150		300		600	
2.5 (65)	.234 (5.943)	15 / 64	.234 (5.943)	15 / 64		
3 (80)	.234 (5.943)	15 / 64	.234 (5.943)	15 / 64	.250 (6.350)	1 / 4
4 (100)	.234 (5.943)	15 / 64	.234 (5.943)	15 / 64	.289 (7.340)	9 / 32
6 (150)	.234 (5.943)	15 / 64	.234 (5.943)	15 / 64	.341 (8.661)	1 -1 / 32
8 (200)	.234 (5.943)	15 / 64	.234 (5.943)	15 / 64	.591 (15.011)	19 / 32
10 (250)	.234 (5.943)	15 / 64	.234 (5.943)	15 / 64	.706 (17.932)	45 / 64
12 (300)	.234 (5.943)	15 / 64	.234 (5.943)	15 / 64	.706 (17.932)	45 / 64
14 (350)	.234 (5.943)	15 / 64	.234 (5.943)	15 / 64	.706 (17.932)	45 / 64
16 (400)	.591 (15.011)	19 / 32	.234 (5.943)	15 / 64	1.032 (26.212)	1 -1 / 32
18 (450)	.706 (17.932)	45 / 64	.706 (17.932)	45 / 64	1.032 (26.212)	1 -1 / 32
20 (500)					1.241 (31.521)	1-1/4
24 (600)	.706 (17.932)	45/64	1.032 (26.212)	1-1/32		
30 (750)	1.033 (26.238)	1-1/32	1.241 (31.521)	1-1/4		
32 (800)	1.033 (26.238)	1-1/32				
36 (900)	1.033 (26.238)	1-1/32	1.241 (31.521)	1-1/4		
40 (1000)	1.241 (31.521)	1-1/4	1.521 (38.633)	1-17/32		
42 (1050)	1.241 (31.521)	1-1/4	1.521 (38.633)	1-17/32		
44 (1100)			1.521 (38.633)	1-17/32		
48 (1200)	1.241 (31.521)	1-1/4	1.521 (38.633)	1-17/32		
54 (1350)	1.521 (38.633)	1-17/32				
60 (1500)	1.521 (38.633)	1-17/32				

No.	DESCRIPTION
1.	BODY
2.	DISC
3.	STEM
4.	TAPER PIN
5.	DISC SPACER
6.	BEARING ASS'Y
7.	GLAND RING
8.	STEM SEAL
9.	THRUST WASHER
10.	RETAINING RING
11.	GLAND RETAINER
12.	STUD
13.	LOCK WASHER
14.	HEX NUT
15.	SEAT ASSEMBLY
16.	SEAT RETAINER PLATE
17.	CAP SCREW
18.	O-RING GASKET
19.	LOCATING PLUG
20.	MOUNTING BRACKET
21.	CAP SCREW
22.	LOCK WASHER

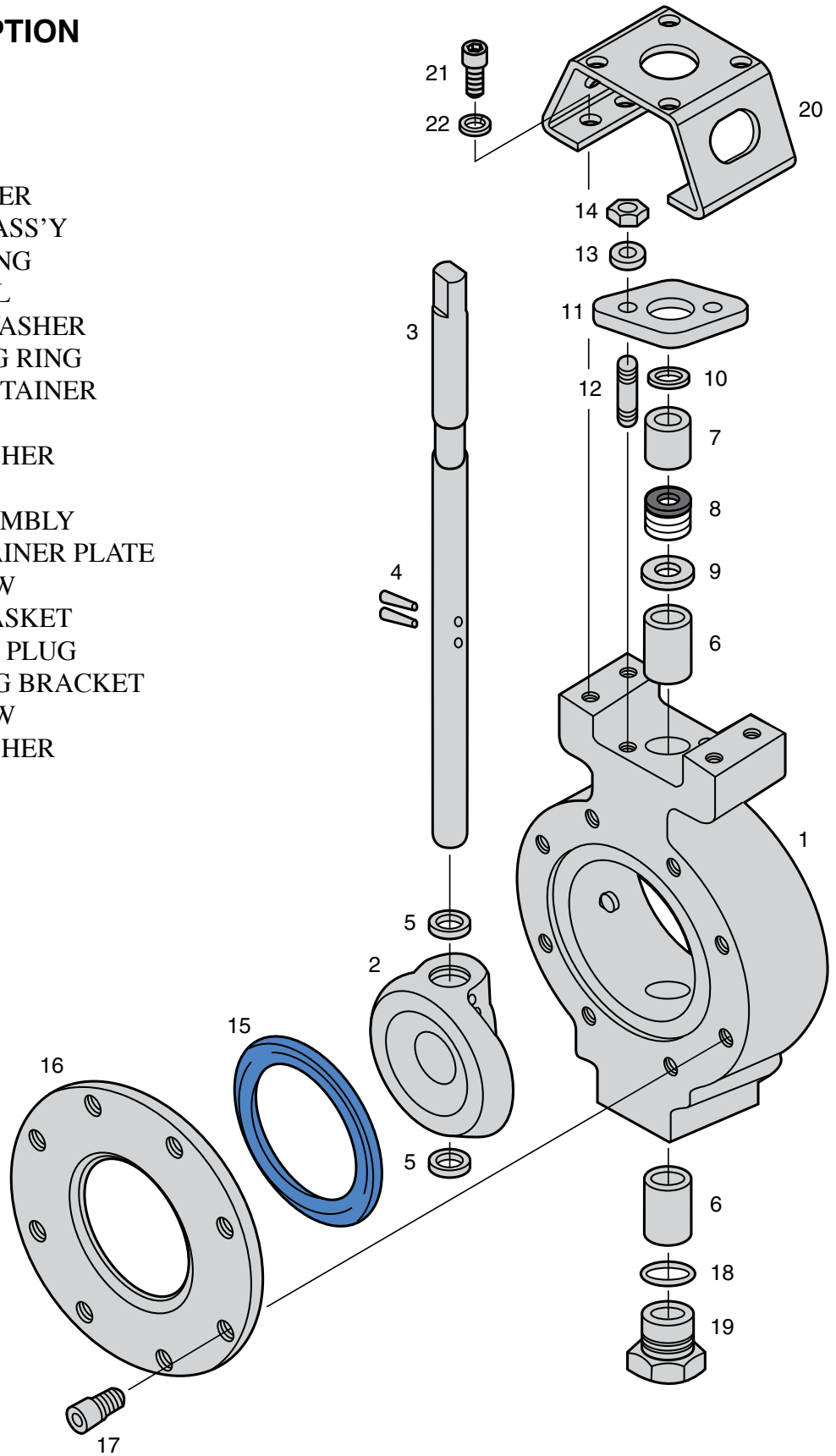

## Special Instructions Fire Safe Bray/McCannalok Installation

- The Fire Safe Bray/McCannalok valve will provide fire safe shutoff with flow in either direction, meeting API 607 and British Standard 6755 part 2 criteria, as well as bubble-tight shutoff in either direction in normal service. However, installation with the seat retainer upstream provides maximum protection to the soft seat, and will increase seat life, especially in erosive services.
- Installation bolting information and dimensional data given for the standard McCannalok valves is also applicable to the Fire Safe versions.

### Stem Seal Replacement

The procedure for replacement on **page 4** also applies to Fire Safe valves, with the following exceptions:

- Graphite stem seals are used in the Fire Safe valves. The arrangement of the two types of stem seals when installed is: bottom seal – carbon fiber braided ring; center seals – graphite rings; top seal – carbon fiber braided ring.
- Table 4** shows stem seal quantities for class 150 and 300 valves.

### Seat Replacement

- With the disc in the closed position, remove the valve from the line.

**WARNING**

Verify line is depressurized prior to removal.

- Lay the valve down with the disc in the closed position and the seat retainer side facing up.
- Remove socket head cap screws, seat retainer, metal fire seat, gaskets, and soft seat.
- Carefully remove graphite gaskets from metal seat. Do not bend or crimp metal seat. All traces of the old gaskets must be removed.
- Clean seat retainer and body surfaces to remove any adhering gasket material, corrosion, or other foreign material. Examine disc seating surfaces for damage, and examine seating surface of metal seat for wear or damage. Replace if damaged.
- Place new seat on disc, carefully centering in body recess.
- Place new graphite gasket on the body. Position metal seat over the disc, lip facing out, on top of the polymer seat. Place another graphite gasket on top of the metal seat. Graphite gaskets can be first attached to the metal seat to simplify the assembly. Spray a suitable adhesive, like 3M Super 77 general purpose adhesive or similar, in 3 or 4 spots on both sides of the metal seat to hold the gaskets in position.

**CAUTION**

Handle the gaskets carefully as they are very thin and are easily torn or scratched.

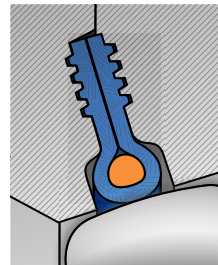

- Align holes in seat retainer with holes in body and seat, and carefully place seat retainer in position, on top of seat.

**CAUTION**

Be careful that seat does not shift when retainer is installed.

Lightly grease cap screw threads and tighten down evenly in a criss-cross pattern to assure proper centering and uniform compression. Torque cap screws to the values given in **Table 2 (pg. 5)**.

- Lubricate the disc edge with molybdenum disulfide spray or similar lubricant, if available. As a minimum, lubricate the disc edge with light machine oil or light grease. Operate valve several times and examine seat for damage before reinstalling in line.

**TABLE 4**

TOTAL NUMBER OF STEM SEALS						
Valve Size Ins (mm)	Class 150		Class 300		Class 600	
	Material CF / G		Material CF / G		Class 600	
2.5 (65)	4	2 / 2	4	2 / 2	NO FIRE SAFE VERSION	
3 (80)	4	2 / 2	4	2 / 2		
4 (100)	4	2 / 2	4	2 / 2		
5 (125)	4	2 / 2	4	2 / 2		
6 (150)	4	2 / 2	4	2 / 2		
8 (200)	5	2 / 3	5	2 / 3		
10 (250)	5	2 / 3	5	2 / 3		
12 (300)	5	2 / 3	5	2 / 3		
14 (350)	6	2 / 4	8	2 / 6		
16 (400)	6	2 / 4	9	2 / 7		
18 (450)	9	2 / 7	9	2 / 7		
20 (500)	9	2 / 7	9	2 / 7		
24 (600)	10	2 / 8	8	2 / 6		

CF = Carbon Fiber    G = Formed Graphite

### GLAND NUT TORQUE - In-lbf (N·m)

Valve Size Ins (mm)	Class 150		Class 300	
2.5 (65)	35	(4)	45	(5)
3 (80)	35	(4)	45	(5)
4 (100)	35	(4)	45	(5)
5 (125)	45	(5)	65	(7)
6 (150)	45	(5)	65	(7)
8 (200)	45	(5)	80	(9)
10 (250)	65	(7)	100	(11)
12 (300)	65	(7)	100	(11)
14 (350)	80	(9)	125	(14)
16 (400)	100	(11)	150	(17)
18 (450)	100	(11)	150	(17)
20 (500)	100	(11)	150	(17)
24 (600)	150	(17)	200	(23)

## Stem and Disc Replacement

The same procedures apply to Fire Safe valves as to the standard valves, with the addition of the special requirements for stem seal and seat replacement.

## Field Adjustments – All Valves

Stem Seal Leakage – Should leakage occur at the stem seals, it may be stopped by retightening the gland retainer nuts to the values specified in **Tables 2 (pg. 5) or 4 (pg. 8)**.

### NOTICE

Do not overtighten gland nuts, as this may cause increased operating torque and improper valve operation or closure.

If the leakage cannot be stopped by this action, the stem seals require replacement.

Adjusting Valve Closure – Valves with gear actuators or electric/pneumatic actuators may require adjustment of the travel stops in the actuator to properly close valve for tight shut-off. The following procedure should be followed to set travel or limit stops. (It is recommended that the valve must be removed from line for this procedure and actuator mounting.)

1. Using a straight-edge and vernier or depth caliper, measure the distances from the face of the seat retainer to the disc (valve closed) face at the 3 o'clock and 9 o'clock positions (stem is at 12 o'clock position). The measurements must agree within 1/16" (0.062").
2. If they do not agree, disc must be rotated in the direction of the larger dimension. If the 3 o'clock dimension is larger, the disc is not fully closed, and must be rotated in the "close" direction more. If 9 o'clock dimension is larger, disc is over-closed, and must be opened slightly.
3. The valve disc is at the full open position when the disc is perpendicular to the body. Set the "open" actuator stop for this position.



### CAUTION

Do not allow the valve to over-open as this may damage the disc seating surfaces by hitting body or attached piping.

4. On gear operators, loosen and adjust the closing stop screw to permit proper disc positioning. Adjust and lock down when disc closure is within measured tolerance in step 1. Open and close valve; recheck measurements before reinstalling in line.

### NOTICE

The setting of the actuation device's close travel stop is important.

The valve has an internal travel limiter to ensure valve disc cannot be over closed.

To ensure that the valve travel limiter is not damaged, the actuator close travel stop bolt must be at a position just before valve disc contacts it's travel limiter.

5. For other power actuators, consult the manufacturer's instructions for setting travel stops, as these vary with actuator model and type.
6. If removing the valve from the line is not practical, as a crude remedy the disc can be placed into a position in the seat at which the leakage stops and travel stops are adjusted to this position.



# **Bray** CONTROLS

A Division of BRAY INTERNATIONAL, Inc.  
13333 Westland East Blvd. Houston, Texas 77041  
281/894-5454 FAX 281/894-9499 [www.bray.com](http://www.bray.com)

Bray® is a registered trademark of BRAY INTERNATIONAL, Inc.  
© 2012 Bray International. All rights reserved. OM-40-001 07-2012