

# Neles™ angle pattern globe valves

## Series AU, AB, AM

Neles A series angle pattern globe valves are economical high-performance control valves designed to provide the best possible control accuracy and wide rangeability with the all inherent benefits of linear control valves. The A series valves are designed for use in modulating control, available with Unbalanced trim, Balanced cage trim and Omega™ multistage trim. They provide reliable operation and are well suited for many different kind of applications.

The angle pattern valves are especially suitable for severe applications where high pressure drop and erosive fluid exist. The flow in an angle valve does not impact directly into the body as it exits the trim, instead, it passes straight down into the downstream piping, which is an advantage if the fluid is erosive and moving at high velocity. Standard valves are equipped with spring diaphragm actuators and Neles intelligent valve controllers for precise flow control, extended operational life and performance monitoring on-line.

### Construction

- Various construction design available with a range of different end styles and connections
- The Omega standard balanced trim design is based on 2 or 3 dimensional multistage cage and balanced plug.
- The multistage trim shape defines the flow path through the valve and flow characteristics of the valve (linear, equal percentage or others), standard trim characteristic is linear.
- The balancing holes are located in the top of the plug. This trim is specially suited to high pressure drop application and is used in the majority of control applications.
- Wide variety of trims with different Cv and characteristics
- Both metal and soft seats are available depending the application
- Optional bellows seal for toxic or other applications where no stem seal leakage is allowed
- Wide material selection for different applications
- Many end connection styles available for different applications
- Extension bonnet design for wide temperature range
- Nickel films are applied as brazing foil to connect disk stacks

### Wide range of applications

- Suitable for gas, liquid and steam
- Wide temperature ranges from -196... +593 °C(-320...+1099 °F) with different bonnet constructions. Temperature limits -29 ... +425 °C / (-20 ... +797 °F) with standard bonnet construction, over +425 °C (+797 °F) and under -29 °C / (-20 °F) with extended bonnets
- Large variation of trim designs for multi-turns and passages for low-noise, and anti-cavitation applications
- Wide range of applicable noise control components, silencers, attenuate plates
- Inherently characterized trim offered in linear, and optionally Equal percentage.
- Large range of trims per size allowing for wide rangeability in process conditions



- Clamped cage for heavy duty guiding on severe service applications
- High integrity cage guiding system
- Double packing available

### Accurate control

- ND9000 digital valve controller for auto-calibration and accurate control
- Accurate and sensitive diaphragm and cylinder actuators
- Stable flow control with high rangeability
- Low-noise, anti-cavitation control and erosion resistant trims
- Streamline flow passage to secure capacity

### Safety and quality

- Rugged one piece body structure to minimizes the leak paths and makes the valve insensitive to pipe stress
- Strictly tested to ensure specified performance with quality assurance systems in according to ISO 9001
- Certified ISO 15848 fugitive emissions
- Certified CE/PED & ATEX, TSG & EAC (GOST-R)
- Certified SIL(Safety Integrity Level) in accordance to IEC61508

### Easy maintenance

- Quick change trim and top entry construction for easy in-line maintenance
- Valve assembly is easy and self guiding
- Flow characteristics can be easily changed with interchangeable trim parts
- Neles digital valve controller with online diagnostics enables performance follow up and predictive maintenance
- Efficient asset management with any FDT frame application and excellent networking capabilities

## AU, Different trim designs

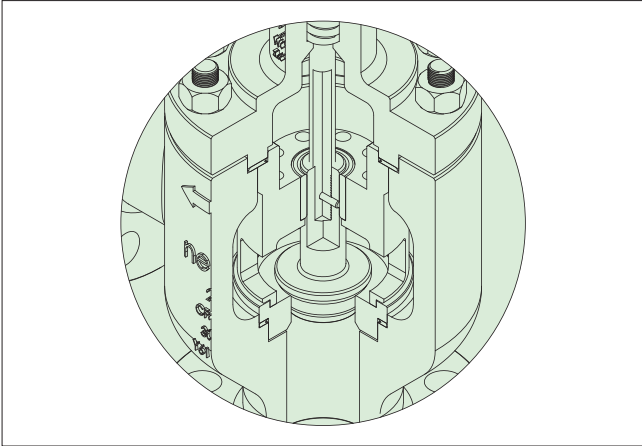

### AU, Standard contoured trim

AU, Quick change standard contoured plug offers a smooth flow profile.

The trim is most suited to low pressure drop application and is used in the majority of control applications.

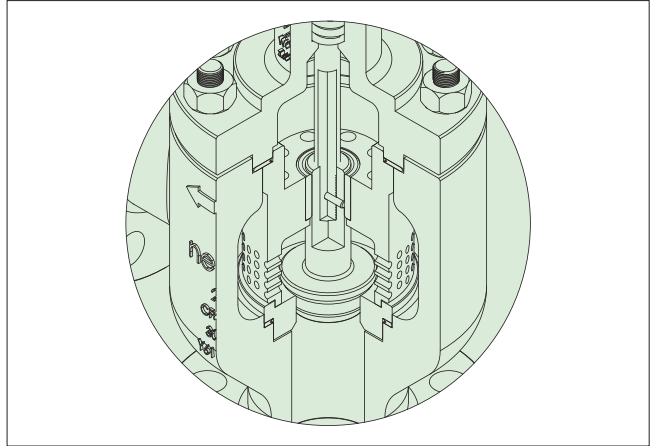

### AU, Tendril trim

AU, Tendril trim is multi drilled hole trim.

This gives excellent resistance to noise on high pressure drop applications.

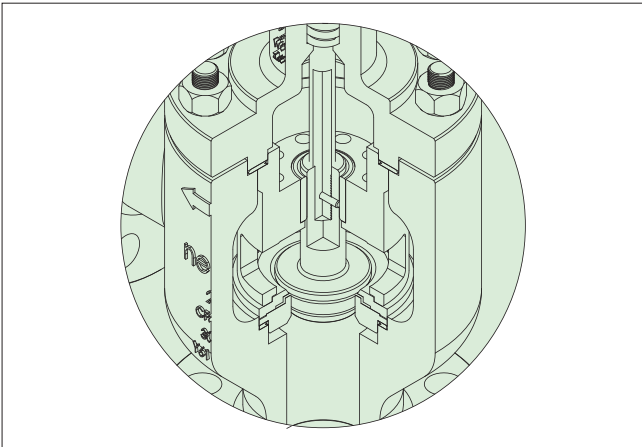

### AU, Soft seat trim

AU, Soft seat option is used on applications where bubble tight shut off, seat leakage class VI is required.

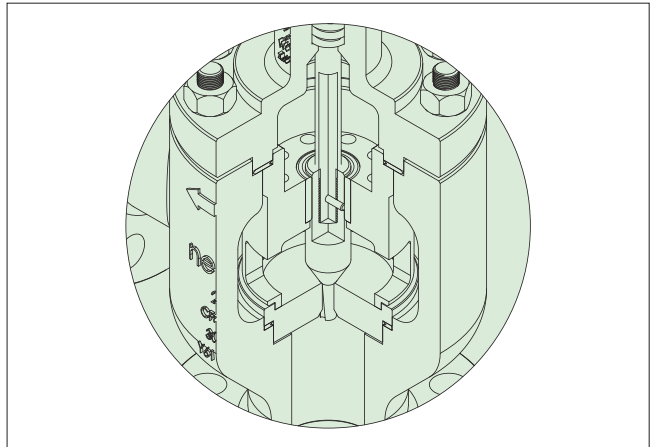

### AU, Micro trim

AU, Micro trim design is an ideal selection for the very low flow rates which is from rated Cv 0.003 to 0.1.

## AB, Different trim designs

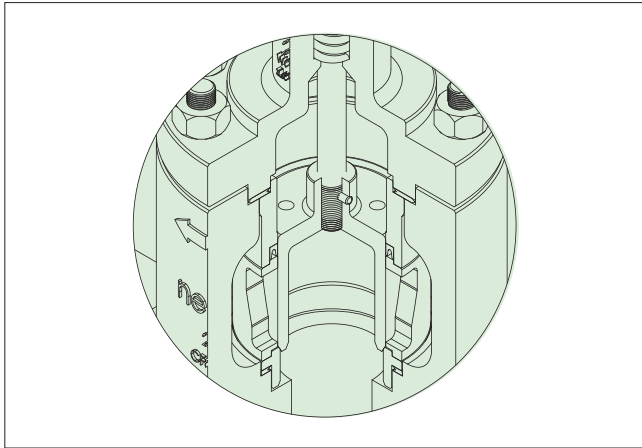

### AB, Quick change, standard cage trim

The standard cage trim is designed with a specially represented window shape cage and balanced plug. The window shape defines the flow path and the flow characteristic of the valve (linear, equal percentage, others). The balancing holes are located in the top of the plug. This trim is suited for both high and low pressure drop application and is used in the majority of control applications.

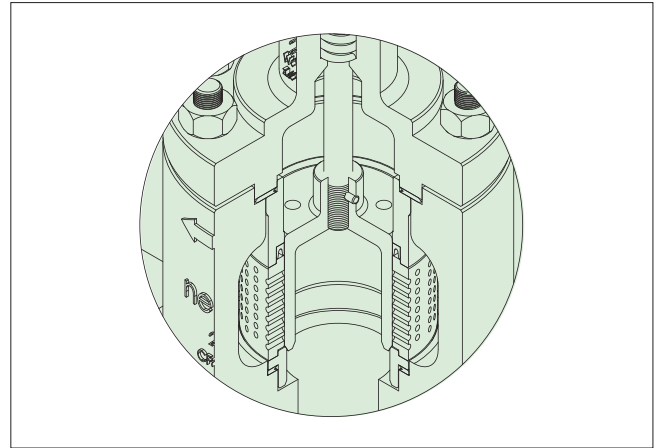

### AB, Tendril™ Multi-hole trim

The trim design presented a multi-hole trim. There are Tendril 1 or Tendril 2 designs in standard depending on pressure drop and potential for cavitation. The pressure drop is divided by multi-hole so that the pressure progressively reduces as it passes through the trim. This gives excellent resistance to cavitation on high pressure drop applications.

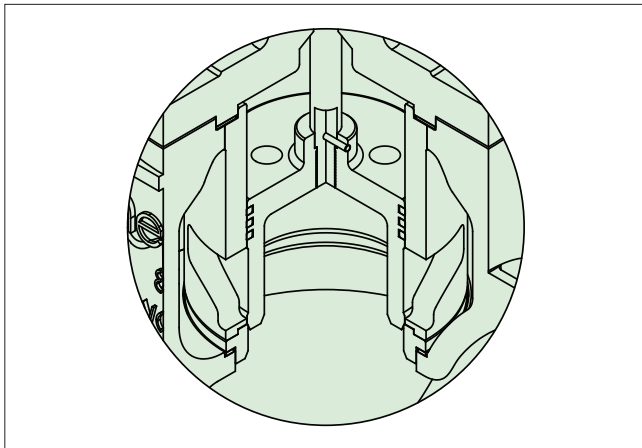

### AB, High temperature graphite seal trim

This design is suitable for various high temperature applications including high pressure applications ultimately. The 3-layer graphite seal rings are inserted on the plug groove surface.

One piece cage leads the stable plug motion to achieve the seat tightness class IV. The trim is suitable with both standard cage and Tendril trims.

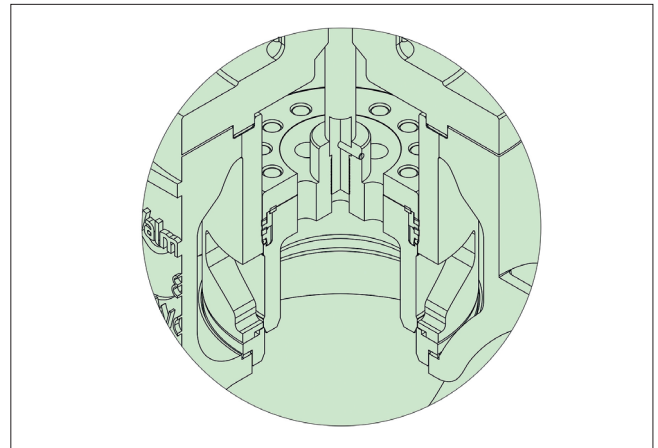

### AB, High temperature metal seal trim

High temperature metal seal trim will enable the valve to achieve tightness of FCI 70-2 Class V at high temperature up to 593°C. This seal is compatible with both standard trim and anti-cavitation trim.

## Different trim designs

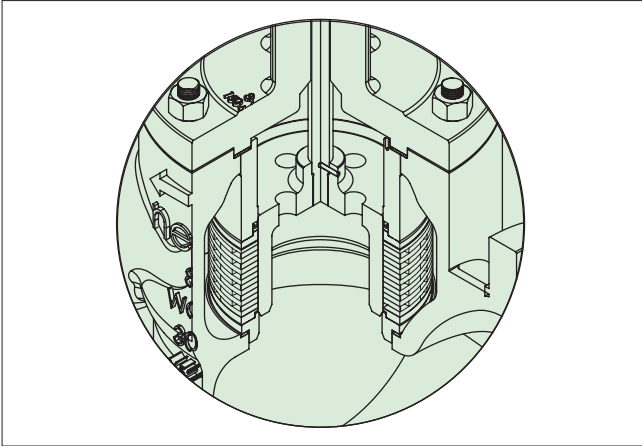

### AM, Omega quick change, Standard balanced trim

The Omega standard balanced trim design is based on 2 or 3 dimensional labyrinth disk stack cage and balanced plug. The opened disk stack shape defines the flow path through the valve and flow characteristics of the valve (linear, equal percentage, others), standard trim characteristic is linear. The balancing holes are located in the top of the plug. This trim is specially suited to high pressure drop application and is used in the majority of control applications.

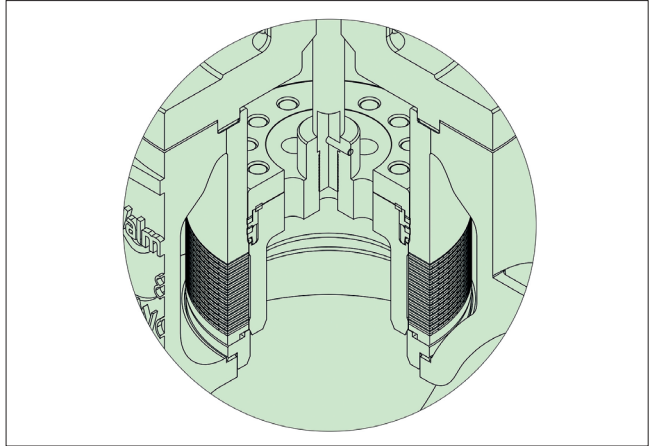

### AM, Omega quick change, High temperature metal seal trim

High temperature metal seal trim will enable the valve to achieve tightness of FCI 70-2 Class V at high temperature up to 593°C. This seal is compatible with both standard trim and anti-cavitation trim.

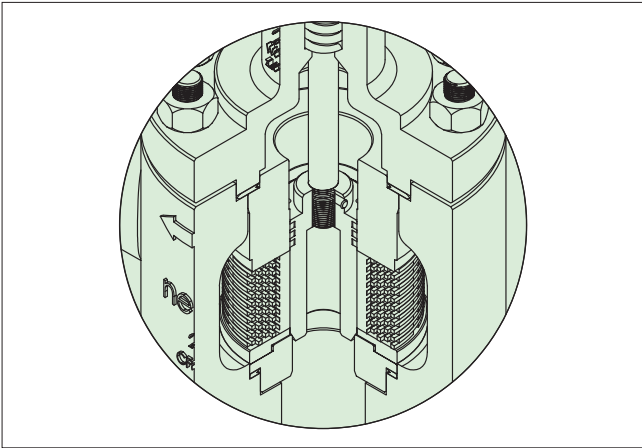

### AM, Omega quick change, High temperature graphite seal trim

This design is suitable for various high temperature applications including high pressure applications ultimately. The 3-layer graphite seal rings are inserted on the plug groove surface. Wide guiding area of Omega leads the stable plug motion to achieve the seat tightness class IV.

## Application guide

### AU, Temperature range & seat leakage class with different bonnet & seat applications

Valve size Inch	ASME rating	Seat type	Temperature range (°C)		Seat leakage class (ANSI B 16.104)	
			Standard bonnet	Extension bonnet	Standard	Optional
Up to 6	150 - 1500	Metal	-29...+425	-196...+593	IV	V
	150 - 600	Soft	-29...+232	-196...+232	VI	

AB/AM, Temperature range by sealing & seat leakage class

### Temperature range

PTFE + Graphite pressure energized seal with metal seat:	-56...+260 °C
PTFE + Graphite + Carbon pressure energized seal with metal seat:	-56...+320 °C
PTFE pressure energized seal with metal seat:	-196...+232 °C
Multiple graphite seals with metal seat:	-56...+540 °C
SELGA seal with metal seat:	-56...+593 °C

### Shut-off classification

ANSI FCI 70-2 Class IV and V available with metal and soft seat.

### High temperature metal seal construction

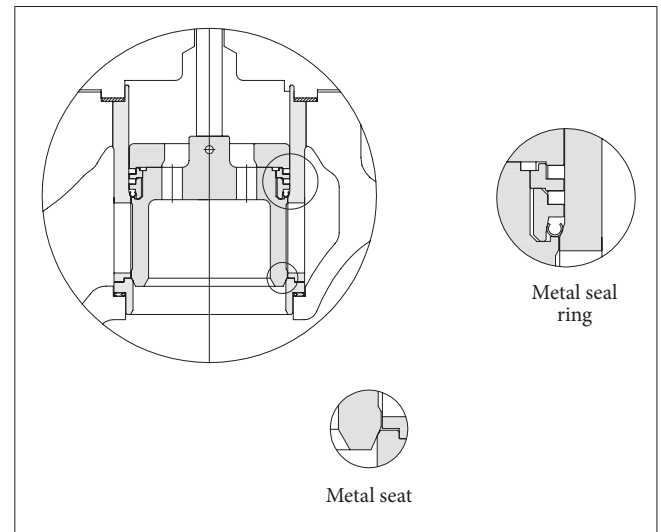

### Pressure energized seal ring construction

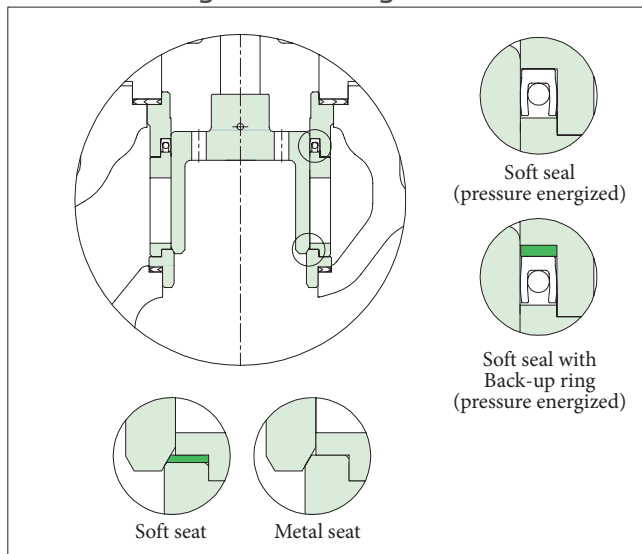

### High temperature metal seal construction

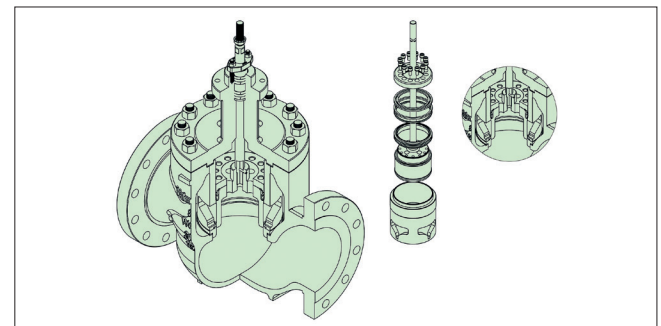

### High temperature graphite seal construction

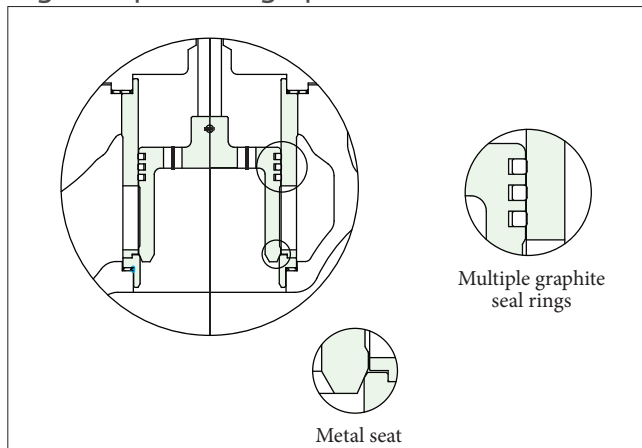

### Temperature range with different body and stud/nut materials

Body, bonnet material	Stud molt, nut application	Temp. range (°C)	Sign 18
Carbon steel (WCB)	ASTM A193-B7M STUD / ASTM A194-2HM NUT	-29...+425	G
Stainless steel (CF3, CF8, CF3M, CF8M)	ASTM A193-B8M / ASTM A194 -8M NUT	-196...+425	D
Stainless steel (CF3, CF8, CF3M, CF8M)	A453 gr. 660 / A453 gr. 660	-196...+593	E
Cr.Mo. Steel (WC6, WC9,C12A)	ASTM A193-B16 STUD / ASTM A194-4 NUT	-29...+593	H

### Trim materials

GB, Trim				Temp.range (°C)	Sign 8, 9, 10, 11, 12, 13
Plug	Stem	Seat	Cage		
410 SS	630 SS	410 SS	630 SS	-29...+425	P1 X BC S1 R1 X
316 SS	316 SS	316 SS	316 SS	-196...+425	T6 X TC S1 T6 X
316 SS + Cobalt based	316 SS	316 SS + Cobalt based	316 SS	-196...+425	T6 A TC S1 T6 A
316SS + Full cobalt based (plug and plug guide)	XM-19	316SS + Full cobalt based	316 SS	-196...+593	T6ATCS1T6A... H(sign 19)
420 J2	XM-19	420 J2	420 J2	-10...+540	P2 X VM S1 P2 X
316 SS	316 SS	316 SS	316 SS + HCr	-196...+425	T6 X TC S1 R6 X
316 SS + Cobalt based	XM-19	316 SS + Cobalt based	316 SS + HCr	-196...+593	T6 A VM S1 R6 A

### Gasket applications

Body, bonnet material	Gasket material	Temp. range (°C)	Sign 17
Carbon steel (WCB)	S/W (Spiral wound) 316L SS + Graphite	-29...+425	S
Stainless steel (CF8, CF8M, CF3, CF3M)	S/W (Spiral wound) 316L SS + Graphite	-56...+425	S
	S/W (Spiral wound) 316L SS + PTFE	-196...+232	L
Stainless steel (CF8, CF8M, CF3, CF3M)	S/W (Spiral wound) 316L SS + Hi Graphite	-29...+593	H
Cr.Mo. Steel (WC6, WC9, C12A)	S/W (Spiral wound) 316L SS + Hi Graphite	-29...+593	H

### Packing applications

Packing material	Temp (°C)	Pressure class	Sign 15
PTFE + Carbon Fiber (Braided TEF + Graphite)	-196...+260	Up to CL900	G
PTFE V-Ring	- 49...+232	Up to CL600	T
Graphite (with Mold + Braided), Standard packing	-196...+400	Up to CL2500	F (with sign 14 'S')
Graphite (with Mold + Braided), Live loaded emission packing	-196...+450	Up to CL2500	F (with sign 14 'E')
Hi-Graphite (with Mold + Braided)	-54...+593	Up to CL2500	H

## Flow direction

AU	General & High temperature		AB	General trim & high temperature trim		Pilot plug trim	
	General	Tendril 1		General	Tendril 1& 2	General	Tendril 1& 2
Gas	FTO or FTC	FTO	Gas	FTC	FTO	FTC	FTC
Liquid	FTO or FTC	FTO or FTC	Liquid	FTC	FTC	FTC	FTC

AM	General trim & high temperature trim		Pilot plug trim	
	Omega		Omega	
Gas	FTO		FTC	
Liquid	FTC		FTC	

\* FTO: Flow to open  
FTC: Flow to close

### Cv ratio

**AU & AB** 50: 1  
**AM** 100: 1

### Flow characteristics

**AU :** Equal percentage, linear  
**AB :** Equal percentage, linear  
**AM :** Equal percentage, linear and customized %

## Packing constructions

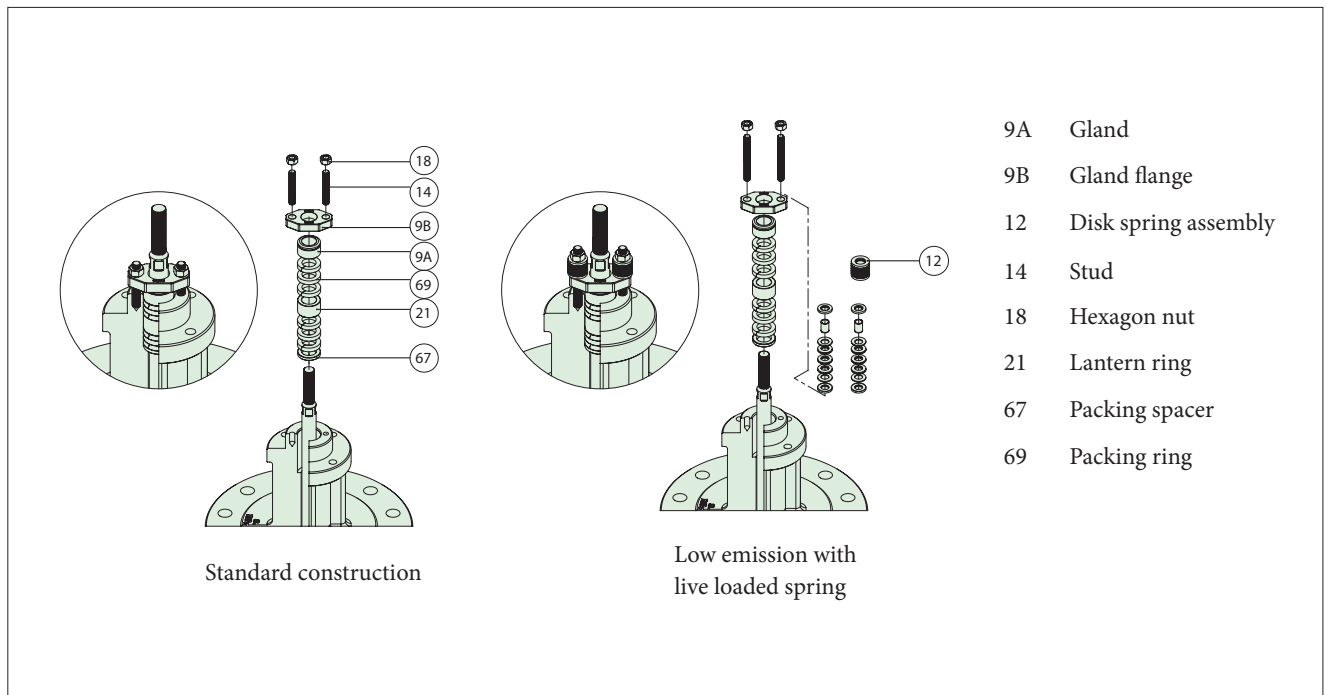

## AU-Components & materials

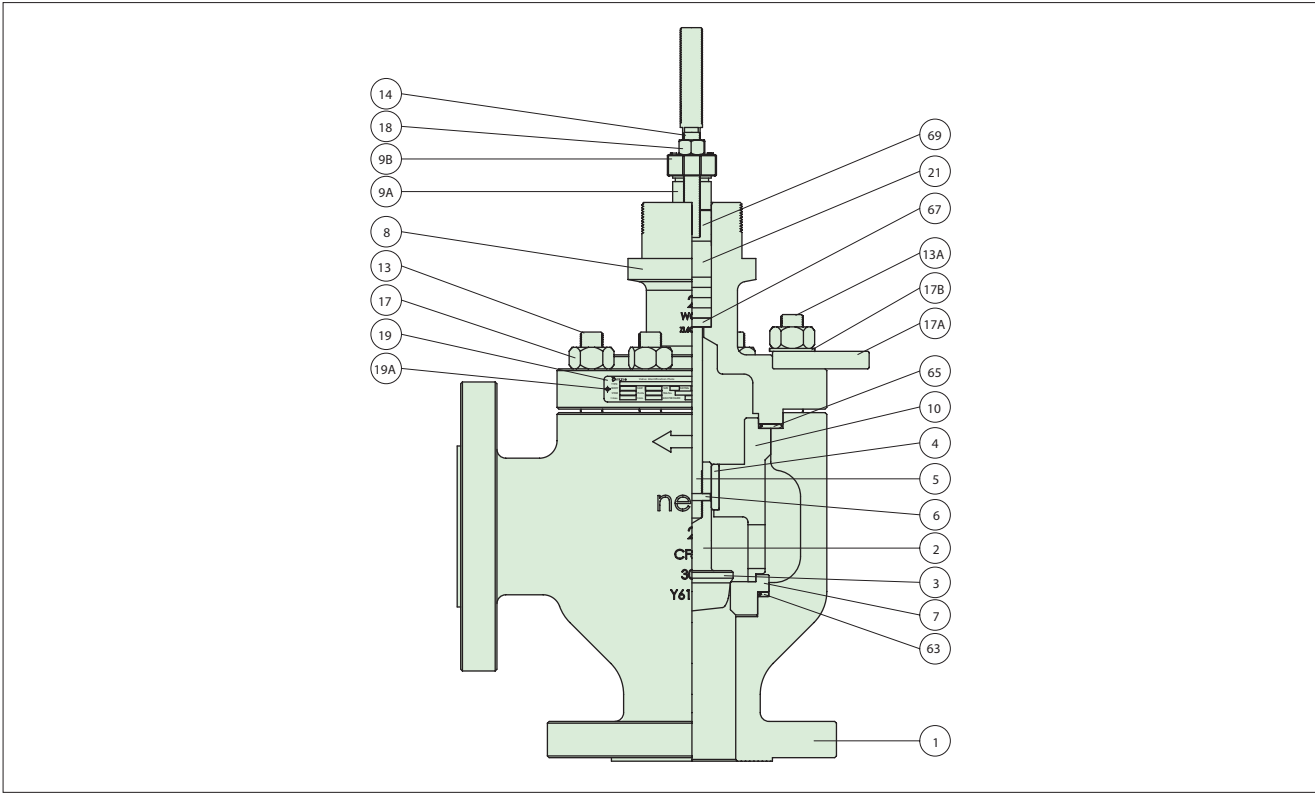

Body material: Carbon steel or alloy steel			Body material: Stainless steel	
Part no.	Description	Material	Material	Spare
1	BODY	A216 WCB / ALLOY STEEL AVAILABLE	A351 CF8M	
2	PLUG SET	410 SS / 630 SS	316 SS / 316 SS	Cat 3
3*	PLUG	410 STAINLESS STEEL	316 STAINLESS STEEL	
5*	STEM	630 STAINLESS STEEL + HCr	316 STAINLESS STEEL + HCr	
6*	PLUG PIN	316 STAINLESS STEEL	316 STAINLESS STEEL	
4	GUIDE BUSHING	440C STAINLESS STEEL	316 + COBALT BASED ALLOY	
7	SEAT RING	410 STAINLESS STEEL	316 STAINLESS STEEL	Cat 3
8	BONNET	A216 WCB / ALLOY STAINLESS STEEL	A351 CF8M	
9A	GLAND	304 STAINLESS STEEL	304 STAINLESS STEEL	
9B	GLAND FLANGE	A351 CF8	A351 CF8	
10	RETAINER	630 STAINLESS STEEL	A351 CF8M	Cat 3
13	STUD	A193 Gr.B7M	A193 Gr. B8M	
13A	STUD	A193 Gr.B7M	A193 Gr. B8M	
14	STUD	A193 Gr.8M	A193 Gr. B8M	
17	HEXAGON NUT	A194 Gr.2HM	A194 Gr. 8M	
17A	LIFTING PLATE	JIS G3101-SS400	JIS G3101-SS400	
17B	SPRING WASHER	AISI 304	AISI 304	
18	HEXAGON NUT	A194 Gr. 8M	A194 Gr. 8M	
19	IDENTIFICATION PLATE	304 STAINLESS STEEL	304 STAINLESS STEEL	
19A	RIVET	304 STAINLESS STEEL	304 STAINLESS STEEL	
21	LANTERN RING	304 STAINLESS STEEL	304 STAINLESS STEEL	
63	SEAT GASKET	S/W GASKET, 316 SS + GRAPHITE	S/W GASKET, 316 SS + GRAPHITE	Cat 1
65	BODY GASKET	S/W GASKET, 316 SS + GRAPHITE	S/W GASKET, 316 SS + GRAPHITE	Cat 1
67	PACKING SPACER	304 STAINLESS STEEL	304 STAINLESS STEEL	
69	PACKING RING	PTFE + CARBON FIBER, GRAPHITE	PTFE + CARBON FIBER, GRAPHITE	Cat 1

**Note.**

1. Plug/Seat hard facing (Cobalt based alloy) & Soft seat are available
2. Materials description  
 316 SS : ASTM A276 TP316 or JIS 316 St. Steel  
 410 SS : ASTM A276 TP410 or JIS 410 St. Steel  
 440C SS : ASTM A276 TP440C or JIS 440C St. Steel  
 17-4PH : ASTM A564 630 (H1100) or JIS 630 (H1100) St. Steel
3. Above standard materials to be applicable depending on specic service conditions, other optional materials to consult Valmet.
4. Optional materials to meet to requirements of NACE MR 01-75 are available
5. The materials are subject to change as equivalent depending on detail design
6. The part no. 3\*, 5\*, 6\* are delivered as a set with no. 2

**Note.**

1. Plug/Seat hard facing (Cobalt based alloy) & Soft seat are available
2. Materials description  
 316 SS : ASTM A276 TP316 or JIS 316 St. Steel
3. Above standard materials to be applicable depending on specic service conditions, other optional materials to consult Valmet.
4. Cryogenic application : ASTM A320 B8M & 8M for studs (13) and nuts (17)
5. Optional materials to meet to requirements of NACE MR 01-75 are available
6. The materials are subject to change as equivalent depending on detail design
7. The part no. 3\*, 5\*, 6\* are delivered as a set with no. 2

## AB-Components & materials

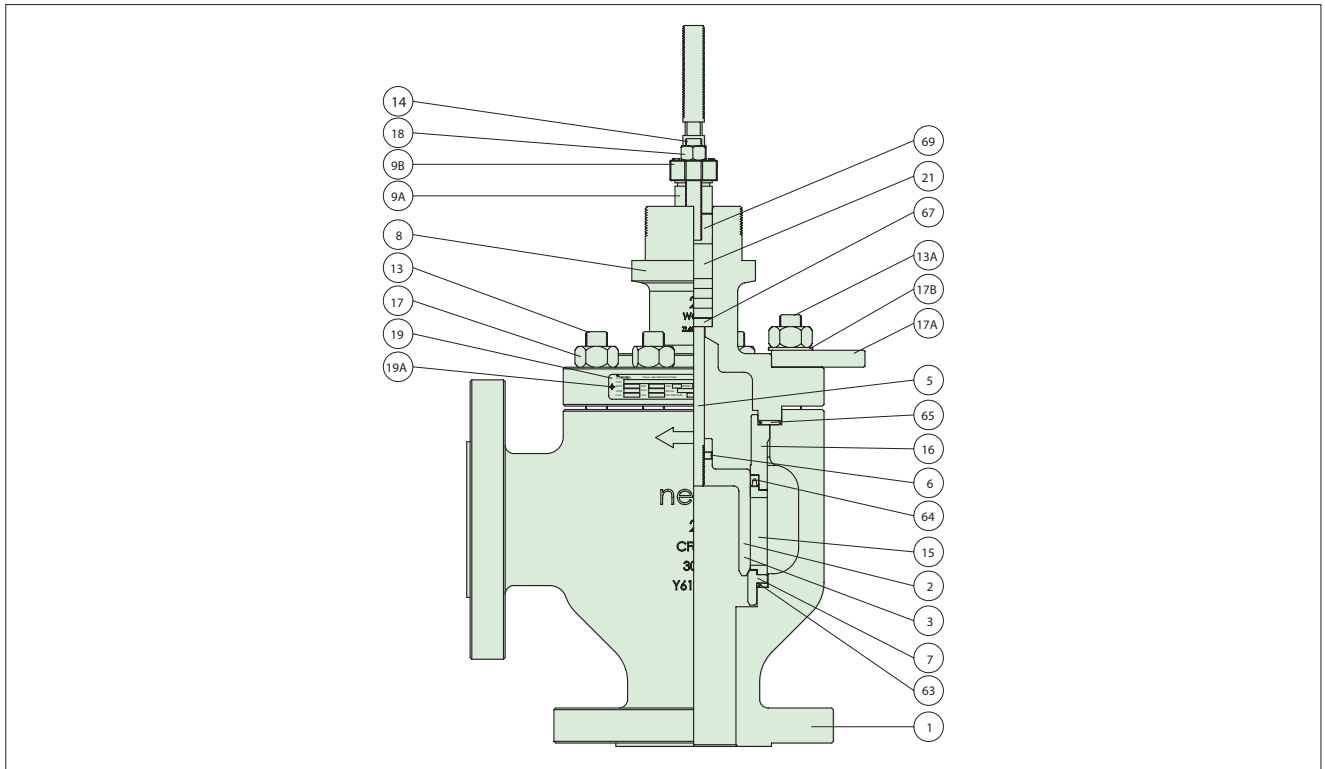

Body material: Carbon steel or alloy steel			Body material: Stainless steel	
Part no.	Description	Material	Material	Spare
1	BODY	A216 WCB / ALLOY STEEL AVAILABLE	A351 CF8M	
2	PLUG SET	410 SS / 630 SS	316 SS / 316 SS	Cat 3
3*	PLUG	410 STAINLESS STEEL	316 STAINLESS STEEL	
5*	STEM	630 STAINLESS STEEL + HCr	316 STAINLESS STEEL + HCr	
6*	PLUG PIN	316 STAINLESS STEEL	316 STAINLESS STEEL	
7	SEAT RING	410 STAINLESS STEEL	316 STAINLESS STEEL	Cat 3
8	BONNET	A216 WCB / ALLOY STAINLESS STEEL	A351 CF8M	
9A	GLAND	304 STAINLESS STEEL	304 STAINLESS STEEL	
9B	GLAND FLANGE	A351 CF8	A351 CF8	
13	STUD	A193 Gr.B7M	A193 Gr. B8M	
13A	STUD	A193 Gr.B7M	A193 Gr. B8M	
14	STUD	A193 Gr.B8M	A193 Gr. B8M	
15	CAGE	630 STAINLESS STEEL + HCr	316 SS + HCr / CF8M + HCr	Cat 3
16	CAGE GUIDE	630 STAINLESS STEEL + HCr	316 SS + HCr / CF8M + HCr	Cat 3
17	HEXAGON NUT	A194 Gr.2HM	A194 Gr. 8M	
17A	LIFTING PLATE	JIS G3101-SS400	JIS G3101-SS400	
17B	SPRING WASHER	AISI 304	AISI 304	
18	HEXAGON NUT	A194 Gr. 8M	A194 Gr. 8M	
19	IDENTIFICATION PLATE	304 STAINLESS STEEL	304 STAINLESS STEEL	
19A	RIVET	304 STAINLESS STEEL	304 STAINLESS STEEL	
21	LANTERN RING	304 STAINLESS STEEL	304 STAINLESS STEEL	
63	SEAT GASKET	S/W GASKET, 316 SS + GRAPHITE	S/W GASKET, 316 SS + GRAPHITE	Cat 1
64	SEAL RING	PTFE + GRAPHITE	PTFE + GRAPHITE	Cat 1
65	BODY GASKET	S/W GASKET, 316 SS + GRAPHITE	S/W GASKET, 316 SS + GRAPHITE	Cat 1
67	PACKING SPACER	304 STAINLESS STEEL	304 STAINLESS STEEL	
69	PACKING RING	PTFE + CARBON FIBER, GRAPHITE	PTFE + CARBON FIBER, GRAPHITE	Cat 1

### Note.

- Plug/Seat hard facing (Cobalt based alloy) & Soft seat are available
- Materials description
  - 316 SS : ASTM A276 TP316 or JIS 316 St. Steel
  - 410 SS : ASTM A276 TP410 or JIS 410 St. Steel
  - 440C SS : ASTM A276 TP440C of JIS 440C St. Steel
  - 17-4PH : ASTM A564 630 (H1100) or JIS 630 (H1100) St. Steel
- Above standard materials to be applicable depending on specific service conditions, other optional materials to consult Valmet
- Optional materials to meet to requirements of NACE MR 01-75 are available
- The materials are subject to change as equivalent depending on detail design
- The part no. 3\*, 5\*, 6\* are delivered as a set with no. 2

### Note.

- Plug/Seat hard facing (Cobalt based alloy) & Soft seat are available
- Materials description
  - 316 SS : ASTM A276 TP316 or JIS 316 St. Steel
- Above standard materials to be applicable depending on specific service conditions, other optional materials to consult Valmet.
- Cryogenic application : ASTM A320 B8M & 8M for studs (13) and nuts (17)
- Optional materials to meet to requirements of NACE MR 01-75 are available
- The materials are subject to change as equivalent depending on detail design
- The part no. 3\*, 5\*, 6\* are delivered as a set with no. 2

## AM-Components & materials

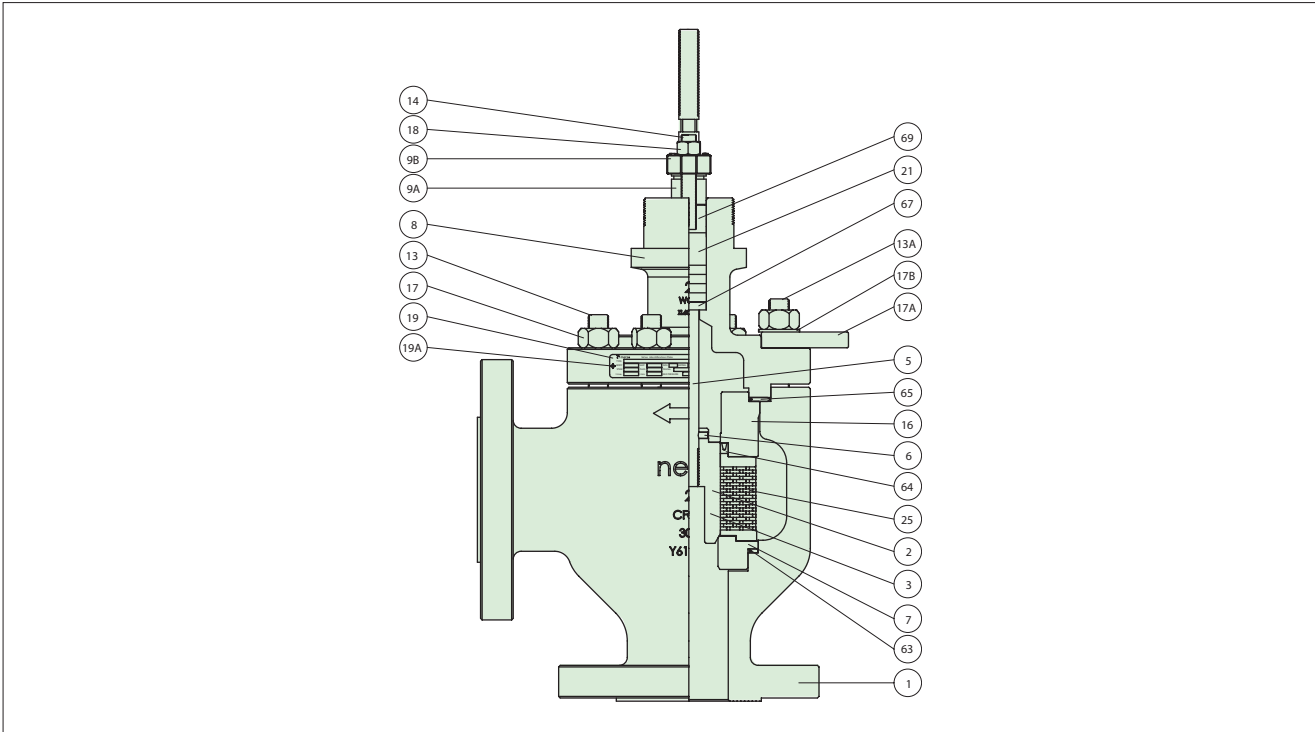

Body material: Stainless steel			Body material: Stainless steel	
Part no.	Description	Material	Material	Spare
1	BODY	A216 WCB / ALLOY STEEL AVAILABLE	A351 CF8M	
2	PLUG SET	420(J2) SS / 630 SS	316 SS / 316 SS	Cat 3
3 *	PLUG	420(J2) STAINLESS STEEL	316 STAINLESS STEEL	
5 *	STEM	630 STAINLESS STEEL + HCr	316 STAINLESS STEEL + HCr	
6 *	PLUG PIN	316 STAINLESS STEEL	316 STAINLESS STEEL	
7	SEAT RING	410 STAINLESS STEEL	316 STAINLESS STEEL	Cat 3
8	BONNET	A216 WCB / ALLOY STEEL AVAILABLE	A351 CF8M	
9A	GLAND	304 STAINLESS STEEL	304 STAINLESS STEEL	
9B	GLAND FLANGE	A351 CF8	A351 CF8	
13	STUD	A193 Gr.B7M	A193 Gr. B8M	
13A	STUD	A193 Gr.B7M	A193 Gr. B8M	
14	STUD	A193 Gr.8M	A193 Gr.B8	
16	CAGE GUIDE	420(J2) STAINLESS STEEL	316 SS + HCr / CF8M + HCr	Cat 3
17	HEXAGON NUT	A194 Gr.2HM	A194 Gr. 8M	
17A	LIFTING PLATE	JIS G3101-SS400	JIS G3101-SS400	
17B	SPRING WASHER	AISI 304	AISI 304	
18	HEXAGON NUT	A194 Gr. 8M	A194 Gr. 8M	
19	IDENTIFICATION PLATE	304 STAINLESS STEEL	304 STAINLESS STEEL	
19A	RIVET	304 STAINLESS STEEL	304 STAINLESS STEEL	
21	LANTERN RING	304 STAINLESS STEEL	304 STAINLESS STEEL	
25	DISK STACK	420(J2) STAINLESS STEEL	316L STAINLESS STEEL	Cat 3
63	SEAT GASKET	S/W GASKET, 316 SS + GRAPHITE	S/W GASKET, 316 SS + GRAPHITE	Cat 1
64	SEAL RING	PTFE + GRAPHITE	PTFE + GRAPHITE	Cat 1
65	BODY GASKET	S/W GASKET, 316 SS + GRAPHITE	S/W GASKET, 316 SS + GRAPHITE	Cat 1
67	PACKING SPACER	304 STAINLESS STEEL	304 STAINLESS STEEL	
69	PACKING RING	PTFE + CARBON FIBER, GRAPHITE	PTFE + CARBON FIBER, GRAPHITE	Cat 1

**Note.**

1. Plug/Seat hard facing (Cobalt based alloy) & Soft seat are available
2. Materials description  
 316 SS : ASTM A276 TP316 or JIS 316 St. Steel  
 410 SS : ASTM A276 TP410 or JIS 410 St. Steel  
 420 SS : ASTM A276 TP420 or JIS 420 St. Steel  
 440C SS : ASTM A276 TP440C or JIS 440C St. Steel  
 17-4PH : ASTM A564 630 (H1100) or JIS 630 H1100) St. Steel
3. Above standard materials to be applicable depending on specic service conditions, other optional materials to consult Valmet.
4. Optional materials to meet to requirements of NACE MR 01-75 are available
5. The materials are subject to change as equivalent depending on detail design
6. The part no. 3\*, 5\*, 6\* are delivered as a set with no. 2

**Note.**

1. Plug/Seat hard facing (Cobalt based alloy) & Soft seat are available
2. Materials description  
 316 SS : ASTM A276 TP316 or JIS 316 St. Steel  
 420 SS : ASTM A276 TP420 or JIS 420 St. Steel
3. Above standard materials to be applicable depending on specic service conditions, other optional materials to consult Valmet.
4. Cryogenic application : ASTM A320 B8M & 8M for studs (13) and nuts (17)
5. Optional materials to meet to requirements of NACE MR 01-75 are available
6. The materials are subject to change as equivalent depending on detail design
7. The part no. 3\*, 5\*, 6\* are delivered as a set with no. 2

## Rated Cv and trim table (Top-guided angle valve, series AU)

Sign	Trim type	Sign	Trim characteristic	Sign	Description	Rated Cv															
						Body size and stroke															
						0.5"	Str.	0.75"	Str.	1"	Str.	1.5"	Str.	2"	Str.	3"	Str.	4"	Str.	6"	Str.
A	General plug	E	Equal %	FC	General / Full capacity	7	(20)	9	(20)	13.5	(20)	28	(20)	49	(20)	100	(40)	190	(40)	295	(60)
			L	Linear	1A	General / 1-Step reduction	4	(20)	5.5	(20)	8.5	(20)	16	(20)	28	(20)	70	(40)	120	(40)	165
				2A	General / 2-Step reduction	2.3	(20)	3	(20)	5.4	(20)	10.5	(20)	17	(20)	42	(40)	72	(40)	85	(60)
				3A	General / 3-Step reduction	1.5	(20)	2	(20)	3.1	(20)	6	(20)	10	(20)	25	(40)	42	(40)	50	(60)
				4A	General / 4-Step reduction	0.8	(20)	1.2	(20)	2	(20)	4	(20)								
				5A	General / 5-Step reduction	0.5	(20)	0.7	(20)	1.2	(20)	2.2	(20)								
				6A	General / 6-Step reduction	0.3	(20)	0.4	(20)	0.8	(20)	1.2	(20)								
				FT	Tendril / Full capacity	7	(20)	9	(20)	13.5	(20)	28	(20)	49	(20)	100	(40)	190	(40)	295	(60)
				1T	Tendril / 1-Step reduction	4	(20)	5.5	(20)	8.5	(20)	16	(20)	28	(20)	70	(40)	120	(40)	165	(60)
				2T	Tendril / 2-Step reduction	2.3	(20)	3	(20)	5.4	(20)	10.5	(20)	17	(20)	42	(40)	72	(40)	85	(60)
				3T	Tendril / 3-Step reduction	1.5	(20)	2	(20)	3.1	(20)	6	(20)	10	(20)	25	(40)	42	(40)	50	(60)
				4T	Tendril / 4-Step reduction	0.8	(20)	1.2	(20)	2	(20)	4	(20)								
				5T	Tendril / 5-Step reduction	0.5	(20)	0.7	(20)	1.2	(20)	2.2	(20)								
				6T	Tendril / 6-Step reduction	0.3	(20)	0.4	(20)	0.8	(20)	1.2	(20)								
C	Micro plug	L	Linear	FC	General / Full capacity	0.1	(20)	0.1	(20)	0.1	(20)										
				1A	General / 1-Step reduction	0.06	(20)	0.06	(20)	0.06	(20)										
				2A	General / 2-Step reduction	0.03	(20)	0.03	(20)	0.03	(20)										
				3A	General / 3-Step reduction	0.01	(20)	0.01	(20)	0.01	(20)										
				4A	General / 4-Step reduction	0.006	(20)	0.006	(20)	0.006	(20)										
				5A	General / 5-Step reduction	0.003	(20)	0.003	(20)	0.003	(20)										
Y	Special	Y	Special	YY	Special	Contact Valmet for Cv details															

- Rated Cv is different depending on trim type and characteristic.
- Str. : valve stroke length (mm). It should be matched with actuator stroke length.

## Rated Cv and trim table (Cage-guided angle valve, series AB)

Sign	Trim type	Sign	Trim characteristic	Sign	Description	Rated Cv											
						Body size and stroke											
						2" Str.	3" Str.	4" Str.	6" Str.	8" Str.	10" Str.	12" Str.	14" Str.	16" Str.			
A	Balanced plug	E	Equal %	FC	General / Full capacity	82 (40)	174 (50)	280 (50)	470 (60)	810 (70)	1250 (80)	1810 (120)	2530 (140)	2960 (160)			
A	High temp graphite seal plug			1A	General / 1-Step reduction	74 (40)	104 (50)	170 (50)	284 (60)	500 (70)	760 (80)	1100 (120)	1540 (140)	1780 (160)			
A	High temp metal seal plug			2A	General / 2-Step reduction	44 (40)	62 (50)	100 (50)	170 (60)	320 (70)	460 (80)	680 (120)	940 (140)	1080 (160)			
				3A	General / 3-Step reduction	26 (40)	40 (50)	64 (50)	100 (60)	200 (70)	280 (80)	420 (120)	580 (140)	660 (160)			
				FT	Tendril 1 / Full capacity	52 (40)	102 (50)	160 (50)	290 (60)	460 (70)	630 (80)	980 (120)	1300 (140)	1580 (160)			
				1T	Tendril 1 / 1-Step reduction	40 (40)	75 (50)	120 (50)	220 (60)	340 (70)	460 (80)	735 (120)	985 (140)	1145 (160)			
				2T	Tendril 1 / 2-Step reduction	27 (40)	40 (50)	70 (50)	130 (60)	195 (70)	255 (80)	405 (120)	565 (140)	670 (160)			
				3T	Tendril 1 / 3-Step reduction	10 (40)	21 (50)	46 (50)	75 (60)	105 (70)	140 (80)	240 (120)	310 (140)	415 (160)			
				FM	Tendril 2 / Full capacity	50 (40)	100 (50)	155 (50)	280 (60)	425 (70)	590 (80)	920 (120)	1240 (140)	1530 (160)			
				1M	Tendril 2 / 1-Step reduction	35 (40)	74 (50)	115 (50)	215 (60)	330 (70)	450 (80)	720 (120)	970 (140)	1130 (160)			
				2M	Tendril 2 / 2-Step reduction	23 (40)	33 (50)	65 (50)	120 (60)	190 (70)	240 (80)	380 (120)	550 (140)	640 (160)			
				3M	Tendril 2 / 3-Step reduction	8 (40)	18 (50)	38 (50)	67 (60)	100 (70)	130 (80)	220 (120)	290 (140)	390 (160)			
		L	Linear	FC	General / Full capacity	76 (40)	160 (50)	256 (50)	430 (60)	740 (70)	1140 (80)	1650 (120)	2300 (140)	2700 (160)			
				1A	General / 1-Step reduction	46 (40)	98 (50)	156 (50)	260 (60)	450 (70)	680 (80)	1000 (120)	1400 (140)	1640 (160)			
				2A	General / 2-Step reduction	28 (40)	60 (50)	94 (50)	156 (60)	270 (70)	410 (80)	640 (120)	840 (140)	980 (160)			
				3A	General / 3-Step reduction	18 (40)	35 (50)	60 (50)	96 (60)	164 (70)	250 (80)	384 (120)	520 (140)	600 (160)			
				FT	Tendril 1 / Full capacity	50 (40)	82 (50)	135 (50)	235 (60)	370 (70)	500 (80)	840 (120)	1110 (140)	1400 (160)			
				1T	Tendril 1 / 1-Step reduction	35 (40)	58 (50)	95 (50)	170 (60)	265 (70)	370 (80)	600 (120)	785 (140)	1020 (160)			
				2T	Tendril 1 / 2-Step reduction	20 (40)	35 (50)	58 (50)	100 (60)	170 (70)	225 (80)	355 (120)	480 (140)	600 (160)			
				3T	Tendril 1 / 3-Step reduction	10 (40)	20 (50)	32 (50)	58 (60)	105 (70)	125 (80)	205 (120)	290 (140)	350 (160)			
				FM	Tendril 2 / Full capacity	47 (40)	74 (50)	130 (50)	230 (60)	330 (70)	470 (80)	770 (120)	1050 (140)	1320 (160)			
				1M	Tendril 2 / 1-Step reduction	33 (40)	56 (50)	92 (50)	165 (60)	245 (70)	330 (80)	570 (120)	720 (140)	960 (160)			
				2M	Tendril 2 / 2-Step reduction	19 (40)	33 (50)	52 (50)	95 (60)	145 (70)	190 (80)	330 (120)	430 (140)	550 (160)			
				3M	Tendril 2 / 3-Step reduction	8 (40)	16 (50)	25 (50)	52 (60)	80 (70)	110 (80)	190 (120)	270 (140)	295 (160)			
Y	Special	Y	Special	YY	Special	Contact Valmet for Cv details											

## Rated Cv and trim table (Omega angle valve, series AM)

20. Sign	Trim type	21. Sign	Trim characteristic	22. Sign	Description	Rated Cv										
						Body size and stroke										
						1" Str.	1.5" Str.	2" Str.	3" Str.	4" Str.	6" Str.	8" Str.	10" Str.	12" Str.	14" Str.	16" Str.
A	Balanced plug	L	Linear	C1	FC / 6 turns / FTC	8.2 (20)	13.7 (20)	41 (40)	70 (50)	110 (50)	160 (60)	270 (70)	370 (80)	580 (120)	800 (140)	1000 (160)
A	High temp. balanced plug			C2	FC / 10 turns / FTC	6.7 (20)	11 (20)	33 (40)	60 (50)	90 (50)	130 (60)	210 (70)	290 (80)	480 (120)	660 (140)	820 (160)
P	Pilot balanced plug			C3	FC / 14 turns / FTC	4.2 (20)	7.8 (20)	27 (40)	48 (50)	60 (50)	110 (60)	140 (70)	200 (80)	340 (120)	470 (140)	650 (160)
U	Unbalanced plug			C4	FC / 18 turns / FTC			21 (40)	29 (50)	48 (50)	80 (60)	110 (70)	160 (80)	280 (120)	390 (140)	530 (160)
				C5	FC / 22 turns / FTC			15 (40)	24 (50)	39 (50)	60 (60)	90 (70)	110 (80)	200 (120)	320 (140)	370 (160)
				CA	1A / 6 turns / FTC	6.2 (20)	6.3 (20)	24 (40)	41 (50)	60 (50)	90 (60)	150 (70)	210 (80)	310 (120)	500 (140)	660 (160)
				CB	1A / 10 turns / FTC	2.9 (20)	5.2 (20)	20 (40)	34 (50)	50 (50)	70 (60)	120 (70)	170 (80)	250 (120)	410 (140)	540 (160)
				CC	1A / 14 turns / FTC	2.4 (20)	5.2 (20)	16 (40)	28 (50)	41 (50)	60 (60)	90 (70)	130 (80)	210 (120)	340 (140)	450 (160)
				CD	1A / 18 turns / FTC			13 (40)	19 (50)	30 (50)	45 (60)	70 (70)	100 (80)	170 (120)	280 (140)	310 (160)
				CE	1A / 22 turns / FTC			8.7 (40)	16 (50)	25 (50)	37 (60)	49 (70)	80 (80)	130 (120)	190 (140)	260 (160)
				O1	FC / 6 turns / FTO	7.2 (20)	12.5 (20)	36 (40)	70 (50)	100 (50)	160 (60)	270 (70)	350 (80)	540 (120)	790 (140)	960 (160)
				O2	FC / 10 turns / FTO	6.9 (20)	10 (20)	29 (40)	55 (50)	90 (50)	140 (60)	220 (70)	300 (80)	470 (120)	650 (140)	790 (160)
				O3	FC / 14 turns / FTO	4.9 (20)	7.2 (20)	24 (40)	45 (50)	60 (50)	110 (60)	150 (70)	200 (80)	350 (120)	480 (140)	620 (160)
				O4	FC / 18 turns / FTO			19 (40)	30 (50)	49 (50)	80 (60)	120 (70)	170 (80)	290 (120)	390 (140)	510 (160)
				O5	FC / 22 turns / FTO			15 (40)	25 (50)	41 (50)	70 (60)	100 (70)	110 (80)	200 (120)	320 (140)	380 (160)
				OA	1A / 6 turns / FTO	5.6 (20)	5.7 (20)	23 (40)	40 (50)	60 (50)	90 (60)	150 (70)	210 (80)	300 (120)	470 (140)	620 (160)
				OB	1A / 10 turns / FTO	2.6 (20)	4.7 (20)	19 (40)	33 (50)	49 (50)	70 (60)	120 (70)	170 (80)	240 (120)	390 (140)	510 (160)
				OC	1A / 14 turns / FTO	2.2 (20)	3.9 (20)	16 (40)	27 (50)	41 (50)	60 (60)	90 (70)	130 (80)	200 (120)	320 (140)	420 (160)
				OD	1A / 18 turns / FTO			13 (40)	19 (50)	30 (50)	46 (60)	70 (70)	100 (80)	170 (120)	260 (140)	290 (160)
				OE	1A / 22 turns / FTO			8.4 (40)	16 (50)	25 (50)	38 (60)	50 (70)	80 (80)	120 (120)	180 (140)	240 (160)
		E	Equal%	C1	FC / 6 turns / FTC	6.6 (20)	10 (20)	34 (40)	60 (50)	90 (50)	130 (60)	210 (70)	300 (80)	500 (120)	690 (140)	860 (160)
				C2	FC / 10 turns / FTC	5.5 (20)	8.3 (20)	28 (40)	46 (50)	70 (50)	110 (60)	160 (70)	230 (80)	410 (120)	570 (140)	710 (160)
				C3	FC / 14 turns / FTC	3.5 (20)	6 (20)	23 (40)	38 (50)	48 (50)	90 (60)	110 (70)	170 (80)	300 (120)	390 (140)	570 (160)
				C4	FC / 18 turns / FTC			16 (40)	22 (50)	39 (50)	60 (60)	90 (70)	140 (80)	250 (120)	320 (140)	470 (160)
				C5	FC / 22 turns / FTC			12 (40)	18 (50)	32 (50)	50 (60)	80 (70)	90 (80)	160 (120)	260 (140)	310 (160)
				CA	1A / 6 turns / FTC	4.5 (20)	6.5 (20)	22 (40)	40 (50)	70 (50)	80 (60)	120 (70)	210 (80)	320 (120)	470 (140)	540 (160)
				CB	1A / 10 turns / FTC	3.7 (20)	5.3 (20)	18 (40)	33 (50)	50 (50)	60 (60)	100 (70)	170 (80)	260 (120)	380 (140)	450 (160)
				CC	1A / 14 turns / FTC	2.6 (20)	4.4 (20)	15 (40)	27 (50)	31 (50)	50 (60)	80 (70)	140 (80)	220 (120)	310 (140)	370 (160)
				CD	1A / 18 turns / FTC			12 (40)	17 (50)	25 (50)	43 (60)	70 (70)	90 (80)	180 (120)	260 (140)	300 (160)
				CE	1A / 22 turns / FTC			7.8 (40)	14 (50)	21 (50)	36 (60)	60 (70)	70 (80)	120 (120)	170 (140)	250 (160)
				O1	FC / 6 turns / FTO	6 (20)	9.2 (20)	32 (40)	60 (50)	90 (50)	140 (60)	210 (70)	290 (80)	470 (120)	690 (140)	850 (160)
				O2	FC / 10 turns / FTO	5.5 (20)	7.6 (20)	26 (40)	46 (50)	70 (50)	110 (60)	180 (70)	250 (80)	410 (120)	570 (140)	700 (160)
				O3	FC / 14 turns / FTO	4 (20)	5.5 (20)	21 (40)	38 (50)	49 (50)	90 (60)	120 (70)	170 (80)	310 (120)	390 (140)	550 (160)
				O4	FC / 18 turns / FTO			16 (40)	23 (50)	41 (50)	70 (60)	100 (70)	140 (80)	250 (120)	320 (140)	450 (160)
				O5	FC / 22 turns / FTO			12 (40)	19 (50)	33 (50)	50 (60)	80 (70)	100 (80)	170 (120)	270 (140)	320 (160)
				OA	1A / 6 turns / FTO	4.1 (20)	5.9 (20)	21 (40)	39 (50)	70 (50)	80 (60)	120 (70)	210 (80)	310 (120)	440 (140)	510 (160)
				OB	1A / 10 turns / FTO	3.4 (20)	4.8 (20)	18 (40)	32 (50)	50 (50)	70 (60)	100 (70)	170 (80)	250 (120)	360 (140)	420 (160)
				OC	1A / 14 turns / FTO	2.8 (20)	4 (20)	14 (40)	26 (50)	31 (50)	50 (60)	80 (70)	140 (80)	210 (120)	300 (140)	340 (160)
				OD	1A / 18 turns / FTO			12 (40)	17 (50)	26 (50)	44 (60)	70 (70)	90 (80)	170 (120)	240 (140)	280 (160)
				OE	1A / 22 turns / FTO			7.6 (40)	14 (50)	21 (50)	36 (60)	60 (70)	70 (80)	110 (120)	160 (140)	230 (160)
Y	Special	Y	Special	YY	Special	Please contact Valmet for more information										

- Rated Cv is different depending on trim type and characteristic.
- FC / FTC / FTO= Full capacity / / Flow to close or Flow to open
- 1A / FTC or FTO = 1-Step reduction / / Flow to open or Flow to close

## AU Series Cv vs Travel (General contoured)

Size: 1/2" ... 6"

Flow characteristic: linear

Valve travel [%]							10	20	30	40	50	60	70	80	90	100	
F <sub>L</sub>							0.94	0.93	0.91	0.90	0.89	0.89	0.88	0.88	0.87	0.77	
Valve size		Orifice diameter			Travel		Rated Cv										
Inch	mm	Sign	Inch	mm	Inch	mm											
1/2"	15	FC	0.6	15.7	0.8	20	0.53	1.27	1.95	2.66	3.38	4.09	4.76	5.51	6.67	7	
		1A	0.4	11.0			0.36	0.74	1.23	1.61	1.99	2.37	2.72	3.05	3.41	4	
		2A	0.3	8.0			0.28	0.53	0.79	1.07	1.32	1.52	1.71	1.88	2.03	2.3	
		3A	0.3	6.4			0.19	0.36	0.52	0.67	0.82	0.97	1.15	1.28	1.38	1.5	
		4A	0.3	6.4			0.09	0.17	0.25	0.32	0.40	0.47	0.54	0.61	0.68	0.8	
		5A	0.3	6.4			0.06	0.11	0.15	0.20	0.25	0.30	0.35	0.40	0.45	0.5	
		6A	0.3	6.4			0.04	0.07	0.10	0.12	0.15	0.18	0.21	0.24	0.27	0.3	
3/4"	20	FC	0.7	17.2	0.8	20	0.85	1.68	2.57	3.31	4.04	4.74	5.43	6.18	7.61	9	
		1A	0.5	13.0			0.35	0.82	1.40	2.17	2.78	3.39	3.98	4.53	5.03	5.5	
		2A	0.4	9.0			0.29	0.74	1.08	1.40	1.73	2.13	2.37	2.60	2.80	3	
		3A	0.3	7.2			0.24	0.44	0.63	0.81	0.99	1.16	1.32	1.47	1.62	2	
		4A	0.3	6.4			0.13	0.24	0.36	0.48	0.60	0.72	0.84	0.96	1.08	1.2	
		5A	0.3	6.4			0.08	0.15	0.22	0.28	0.35	0.42	0.49	0.56	0.63	0.7	
		6A	0.3	6.4			0.05	0.09	0.13	0.17	0.21	0.25	0.28	0.32	0.36	0.4	
1"	25	FC	0.9	22.3	0.8	20	1.29	2.62	4.02	5.42	6.83	8.13	8.90	10.25	11.93	13.5	
		1A	0.6	15.0			0.77	1.54	2.31	3.15	3.92	4.68	5.42	6.12	7.00	8.5	
		2A	0.5	11.5			0.46	0.94	1.43	1.94	2.46	3.02	3.52	4.00	4.44	5.4	
		3A	0.4	9.0			0.28	0.56	0.86	1.16	1.47	1.77	2.07	2.36	2.66	3.1	
		4A	0.3	7.2			0.18	0.37	0.57	0.78	0.99	1.20	1.41	1.61	1.79	2	
		5A	0.3	6.4			0.11	0.23	0.35	0.47	0.59	0.71	0.83	0.95	1.07	1.2	
		6A	0.3	6.4			0.07	0.14	0.21	0.28	0.34	0.41	0.48	0.55	0.62	0.8	
1-1/2"	40	FC	1.2	30.0	0.8	20	2.64	5.38	8.46	11.77	15.22	18.77	21.56	24.09	26.50	28	
		1A	0.8	21.5			1.63	3.16	4.70	6.25	7.90	9.52	11.12	12.68	14.18	16	
		2A	0.6	16.0			0.95	1.89	2.86	3.86	4.88	5.88	6.90	7.92	8.86	10.5	
		3A	0.5	12.5			0.57	1.13	1.72	2.33	2.96	3.58	4.19	4.78	5.33	6	
		4A	0.4	10.0			0.37	0.74	1.14	1.54	1.96	2.38	2.79	3.18	3.55	4	
		5A	0.3	7.0			0.19	0.38	0.57	0.78	0.99	1.19	1.40	1.60	1.78	2.2	
		6A	0.3	6.4			0.12	0.24	0.36	0.47	0.59	0.71	0.83	0.95	1.06	1.2	
2"	50	FC	1.7	43.9	0.8	20	4.13	9.24	14.48	19.71	25.09	30.56	35.97	40.01	44.64	49	
		1A	1.3	33.4			2.27	4.97	7.88	10.94	13.72	16.51	19.28	22.03	24.97	28	
		2A	0.8	21.5			1.26	2.76	4.37	6.05	7.77	9.53	11.23	12.73	14.32	17	
		3A	0.6	16.0			0.82	1.78	2.80	3.86	4.93	5.98	7.01	7.98	8.89	10	
3"	80	FC	2.8	72.0	1.5	40	9.96	21.06	32.40	42.65	52.98	63.70	76.67	86.07	91.15	100	
		1A	1.9	47.0			5.35	11.64	18.74	26.58	33.66	40.46	47.18	53.74	60.34	70	
		2A	1.3	34.0			3.47	7.21	11.20	15.38	19.69	24.06	28.45	31.99	35.66	42	
		3A	1.0	25.0			2.17	4.47	6.86	9.32	11.81	14.29	16.73	19.08	21.29	25	
4"	100	FC	3.6	91.5	1.5	40	12.67	27.12	47.27	66.04	85.99	106.88	127.85	147.47	167.93	190	
		1A	2.4	60.0			7.32	15.77	25.33	36.43	51.05	63.30	75.78	88.32	103.94	120	
		2A	1.7	43.0			7.02	13.84	20.64	27.41	34.07	43.44	50.85	57.09	63.09	72	
		3A	1.3	32.0			4.03	8.16	12.45	16.82	21.18	25.44	29.51	33.31	37.67	42	
6"	150	FC	4.5	115.0	2.4	60	28.43	57.15	86.05	112.26	136.07	159.16	181.59	212.57	263.12	295	
		1A	3.0	75.0			16.09	32.01	47.67	63.09	78.18	93.11	105.76	117.42	137.91	165.	
		2A	1.8	46.5			8.78	17.43	25.90	34.15	42.13	49.78	57.07	63.94	71.49	85	
		3A	1.4	35.5			4.32	9.07	14.14	19.45	24.88	30.32	35.64	40.72	45.42	50	

## AU Series Cv vs Travel (General contoured)

Size: 1/2" ... 6"

Flow characteristic: EQ%

Valve travel [%]							10	20	30	40	50	60	70	80	90	100
F <sub>L</sub>							0.94	0.94	0.93	0.93	0.92	0.90	0.89	0.88	0.87	0.77
Valve size		Orifice diameter			Travel		Rated Cv									
Inch	mm	Sign	Inch	mm	Inch	mm										
1/2"	15	FC	0.6	15.7	0.8	20	0.16	0.36	0.56	0.89	1.38	2.16	3.42	4.84	6.44	7
		1A	0.4	11.0			0.06	0.16	0.31	0.49	0.78	1.46	2.17	2.88	3.53	4
		2A	0.3	8.0			0.08	0.16	0.23	0.34	0.59	0.94	1.37	1.70	2.01	2.3
		3A	0.3	6.4			0.05	0.09	0.14	0.20	0.35	0.56	0.82	1.11	1.33	1.5
		4A	0.3	6.4			0.02	0.04	0.06	0.08	0.16	0.28	0.41	0.54	0.66	0.8
		5A	0.3	6.4			0.01	0.02	0.04	0.05	0.10	0.17	0.25	0.33	0.41	0.5
		6A	0.3	6.4			0.01	0.01	0.02	0.03	0.06	0.11	0.15	0.20	0.25	0.3
3/4"	20	FC	0.7	17.2	0.8	20	0.24	0.45	0.67	1.07	1.85	2.93	4.02	5.23	7.13	9
		1A	0.5	13.0			0.06	0.20	0.40	0.67	1.11	1.79	2.79	3.71	4.74	5.5
		2A	0.4	9.0			0.05	0.17	0.28	0.45	0.78	1.20	1.80	2.35	2.72	3
		3A	0.3	7.2			0.04	0.09	0.15	0.21	0.41	0.68	1.00	1.30	1.67	2
		4A	0.3	6.4			0.03	0.06	0.09	0.13	0.25	0.42	0.62	0.82	1.01	1.2
		5A	0.3	6.4			0.01	0.03	0.05	0.08	0.14	0.23	0.34	0.45	0.58	0.7
		6A	0.3	6.4			0.01	0.02	0.03	0.04	0.08	0.14	0.21	0.27	0.33	0.4
1"	25	FC	0.9	22.3	0.8	20	0.27	0.57	0.91	1.55	2.75	4.66	7.08	9.49	11.63	13.5
		1A	0.6	15.0			0.12	0.29	0.51	0.83	1.56	2.70	4.14	5.61	7.03	8.5
		2A	0.5	11.5			0.07	0.19	0.33	0.53	0.97	1.67	2.65	3.59	4.37	5.4
		3A	0.4	9.0			0.03	0.09	0.19	0.32	0.58	1.00	1.52	2.05	2.54	3.1
		4A	0.3	7.2			0.03	0.08	0.13	0.22	0.40	0.67	1.00	1.35	1.70	2
		5A	0.3	6.4			0.03	0.05	0.08	0.13	0.25	0.43	0.64	0.85	1.06	1.2
		6A	0.3	6.4			0.01	0.03	0.04	0.07	0.14	0.24	0.35	0.46	0.59	0.8
1-1/2"	40	FC	1.2	30.0	0.8	20	0.45	1.12	2.00	3.07	5.91	10.57	16.18	21.57	25.66	28
		1A	0.8	21.5			0.23	0.58	1.06	1.69	3.16	5.36	7.97	10.69	13.44	16
		2A	0.6	16.0			0.20	0.44	0.71	1.02	1.88	3.25	4.93	6.71	8.59	10.5
		3A	0.5	12.5			0.09	0.22	0.40	0.62	1.13	2.02	3.17	4.26	5.21	6
		4A	0.4	10.0			0.05	0.14	0.26	0.41	0.79	1.36	2.08	2.83	3.45	4
		5A	0.3	7.0			0.03	0.08	0.13	0.21	0.39	0.69	1.07	1.43	1.74	2.2
		6A	0.3	6.4			0.03	0.06	0.09	0.13	0.23	0.40	0.59	0.78	0.98	1.2
2"	50	FC	1.7	43.9	0.8	20	1.21	2.46	3.31	5.12	9.42	16.83	26.55	36.59	44.52	49
		1A	1.3	33.4			0.32	0.82	1.51	2.87	5.48	9.31	13.77	18.31	23.17	28
		2A	0.8	21.5			0.17	0.47	0.88	1.63	3.18	5.47	8.21	11.09	13.68	17
		3A	0.6	16.0			0.15	0.37	0.66	1.02	1.89	3.29	5.01	6.71	8.41	10
3"	80	FC	2.8	72.0	1.5	40	2.01	4.47	7.37	12.28	22.52	38.62	62.02	79.57	90.09	100
		1A	1.9	47.0			1.00	2.51	4.50	6.96	12.95	23.65	36.15	47.82	58.70	70
		2A	1.3	34.0			0.73	1.61	2.64	3.95	7.53	13.57	21.26	28.97	34.99	42
		3A	1.0	25.0			0.36	0.89	1.59	2.46	4.51	8.08	12.55	16.82	20.78	25
4"	100	FC	3.6	91.5	1.5	40	2.90	6.72	11.48	17.16	29.35	56.26	86.65	120.90	153.84	190
		1A	2.4	60.0			1.56	3.77	6.63	10.11	18.42	32.83	55.27	77.53	98.63	120
		2A	1.7	43.0			1.45	3.05	4.82	8.10	14.86	24.20	35.22	49.81	61.14	72
		3A	1.3	32.0			0.88	1.82	2.84	4.44	8.42	14.38	21.12	27.79	34.17	42
6"	150	FC	4.5	115.0	2.4	60	4.23	9.72	16.43	25.73	49.58	89.69	140.01	195.77	256.78	295
		1A	3.0	75.0			2.83	6.73	11.68	17.72	31.53	53.90	88.38	113.11	140.55	165
		2A	1.8	46.5			1.36	3.61	6.68	10.62	17.82	28.66	42.88	57.38	71.53	85
		3A	1.4	35.5			0.91	1.90	2.95	4.26	7.77	13.68	21.42	29.72	37.96	50

## NOTE

Cv: Valve flow coefficient

FL: Liquid pressure recovery factor

FC: Full capacity      1A: 1-Step reduction

2A: 2-Step reduction      3A: 3-Step reduction

4A: 4-Step reduction      5A: 5-Step reduction

## AU Series Cv vs Travel (Tendril 1)

Size: 1/2" ... 4"

Flow characteristic: linear

Valve travel [%]							10	20	30	40	50	60	70	80	90	100				
F <sub>L</sub>							0.95	0.95	0.95	0.94	0.94	0.94	0.93	0.93	0.91	0.91				
Valve size		Orifice diameter			Travel		Rated Cv													
Inch	mm	Sign	Inch	mm	Inch	mm														
1/2"	15	FT	0.6	15.7	0.8	20	0.53	1.27	1.95	2.66	3.38	4.09	4.76	5.51	6.67	7				
		1T	0.4	11.0			0.36	0.74	1.23	1.61	1.99	2.37	2.72	3.05	3.41	4				
		2T	0.3	8.0			0.28	0.53	0.79	1.07	1.32	1.52	1.71	1.88	2.03	2.3				
		3T	0.3	6.4			0.19	0.36	0.52	0.67	0.82	0.97	1.15	1.28	1.38	1.5				
		4T	0.3	6.4			0.09	0.17	0.25	0.32	0.40	0.47	0.54	0.61	0.68	0.8				
		5T	0.3	6.4			0.06	0.11	0.15	0.20	0.25	0.30	0.35	0.40	0.45	0.5				
3/4"	20	FT	0.7	17.2	0.8	20	0.85	1.68	2.57	3.31	4.04	4.74	5.43	6.18	7.61	9				
		1T	0.5	13.0			0.35	0.82	1.40	2.17	2.78	3.39	3.98	4.53	5.03	5.5				
		2T	0.4	9.0			0.29	0.74	1.08	1.40	1.73	2.13	2.37	2.60	2.80	3				
		3T	0.3	7.2			0.24	0.44	0.63	0.81	0.99	1.16	1.32	1.47	1.62	2				
		4T	0.3	6.4			0.13	0.24	0.36	0.48	0.60	0.72	0.84	0.96	1.08	1.2				
		5T	0.3	6.4			0.08	0.15	0.22	0.28	0.35	0.42	0.49	0.56	0.63	0.7				
1"	25	FT	0.9	22.3	0.8	20	1.29	2.62	4.02	5.42	6.83	8.13	8.90	10.25	11.93	13.5				
		1T	0.6	15.0			0.77	1.54	2.31	3.15	3.92	4.68	5.42	6.12	7.00	8.5				
		2T	0.5	11.5			0.46	0.94	1.43	1.94	2.46	3.02	3.52	4.00	4.44	5.4				
		3T	0.4	9.0			0.28	0.56	0.86	1.16	1.47	1.77	2.07	2.36	2.66	3.1				
		4T	0.3	7.2			0.18	0.37	0.57	0.78	0.99	1.20	1.41	1.61	1.79	2				
		5T	0.3	6.4			0.11	0.23	0.35	0.47	0.59	0.71	0.83	0.95	1.07	1.2				
1-1/2"	40	FT	1.2	30.0	0.8	20	2.64	5.38	8.46	11.77	15.22	18.77	21.56	24.09	26.50	28				
		1T	0.8	21.5			1.63	3.16	4.70	6.25	7.90	9.52	11.12	12.68	14.18	16				
		2T	0.6	16.0			0.95	1.89	2.86	3.86	4.88	5.88	6.90	7.92	8.86	10.5				
		3T	0.5	12.5			0.57	1.13	1.72	2.33	2.96	3.58	4.19	4.78	5.33	6				
		4T	0.4	10.0			0.37	0.74	1.14	1.54	1.96	2.38	2.79	3.18	3.55	4				
		5T	0.3	7.0			0.19	0.38	0.57	0.78	0.99	1.19	1.40	1.60	1.78	2.2				
2"	50	FT	1.7	43.9	0.8	20	4.13	9.24	14.48	19.71	25.09	30.56	35.97	40.01	44.64	49				
		1T	1.3	33.4			2.27	4.97	7.88	10.94	13.72	16.51	19.28	22.03	24.97	28				
		2T	0.8	21.5			1.26	2.76	4.37	6.05	7.77	9.53	11.23	12.73	14.32	17				
		3T	0.6	16.0			0.82	1.78	2.80	3.86	4.93	5.98	7.01	7.98	8.89	10				
		3"	80	FT			2.8	72.0	1.5	40	9.96	21.06	32.40	42.65	52.98	63.70	76.67	86.07	91.15	100
				1T			1.9	47.0			5.35	11.64	18.74	26.58	33.66	40.46	47.18	53.74	60.34	70
2T	1.3			34.0	3.47	7.21	11.20	15.38			19.69	24.06	28.45	31.99	35.66	42				
3T	1.0			25.0	2.17	4.47	6.86	9.32			11.81	14.29	16.73	19.08	21.29	25				
4"	100			FT	3.6	91.5	1.5	40			12.67	27.12	47.27	66.04	85.99	106.88	127.85	147.47	167.93	190
				1T	2.4	60.0					7.32	15.77	25.33	36.43	51.05	63.30	75.78	88.32	103.94	120
		2T	1.7	43.0	7.02	13.84			20.64	27.41	34.07	43.44	50.85	57.09	63.09	72				
		3T	1.3	32.0	4.03	8.16			12.45	16.82	21.18	25.44	29.51	33.31	37.67	42				

**NOTE**

Cv: Valve flow coefficient

FL: Liquid pressure recovery factor

FT: Full capacity      1T: 1-Step reduction

2T: 2-Step reduction      3T: 3-Step reduction

4T: 4-Step reduction      5T: 5-Step reduction

6T: 6-Step reduction

## AU Series Cv vs Travel (Tendril 1)

Size: 1/2" ... 4"

Flow characteristic: EQ%

Valve travel [%]							10	20	30	40	50	60	70	80	90	100		
F <sub>L</sub>							0.95	0.95	0.95	0.95	0.95	0.945	0.94	0.93	0.91	0.91		
Valve size		Orifice diameter			Travel		Rated Cv											
Inch	mm	Sign	Inch	mm	Inch	mm												
1/2"	15	FT	0.6	15.7	0.8	20	0.16	0.36	0.56	0.89	1.38	2.16	3.42	4.84	6.44	7.0		
		1T	0.4	11			0.06	0.16	0.31	0.49	0.78	1.46	2.17	2.88	3.53	4.0		
		2T	0.3	8			0.08	0.16	0.23	0.34	0.59	0.94	1.37	1.70	2.01	2.3		
		3T	0.3	6.4			0.05	0.09	0.14	0.20	0.35	0.56	0.82	1.11	1.33	1.5		
		4T	0.3	6.4			0.02	0.04	0.06	0.08	0.16	0.28	0.41	0.54	0.66	0.8		
		5T	0.3	6.4			0.01	0.02	0.04	0.05	0.10	0.17	0.25	0.33	0.41	0.5		
3/4"	20	FT	0.7	17.2	0.8	20	0.24	0.45	0.67	1.07	1.85	2.93	4.02	5.23	7.13	9.0		
		1T	0.5	13			0.06	0.20	0.40	0.67	1.11	1.79	2.79	3.71	4.74	5.5		
		2T	0.4	9			0.05	0.17	0.28	0.45	0.78	1.20	1.80	2.35	2.72	3.0		
		3T	0.3	7.2			0.04	0.09	0.15	0.21	0.41	0.68	1.00	1.30	1.67	2.0		
		4T	0.3	6.4			0.03	0.06	0.09	0.13	0.25	0.42	0.62	0.82	1.01	1.2		
		5T	0.3	6.4			0.01	0.03	0.05	0.08	0.14	0.23	0.34	0.45	0.58	0.7		
1"	25	FT	0.9	22.3	0.8	20	0.27	0.57	0.91	1.55	2.75	4.66	7.08	9.49	11.63	13.5		
		1T	0.6	15			0.12	0.29	0.51	0.83	1.56	2.70	4.14	5.61	7.03	8.5		
		2T	0.5	11.5			0.07	0.19	0.33	0.53	0.97	1.67	2.65	3.59	4.37	5.4		
		3T	0.4	9			0.03	0.09	0.19	0.32	0.58	1.00	1.52	2.05	2.54	3.1		
		4T	0.3	7.2			0.03	0.08	0.13	0.22	0.40	0.67	1.00	1.35	1.70	2.0		
		5T	0.3	6.4			0.03	0.05	0.08	0.13	0.25	0.43	0.64	0.85	1.06	1.2		
1-1/2"	40	FT	1.2	30	0.8	20	0.45	1.12	2.00	3.07	5.91	10.57	16.18	21.57	25.66	28.0		
		1T	0.8	21.5			0.23	0.58	1.06	1.69	3.16	5.36	7.97	10.69	13.44	16.0		
		2T	0.6	16			0.20	0.44	0.71	1.02	1.88	3.25	4.93	6.71	8.59	10.5		
		3T	0.5	12.5			0.09	0.22	0.40	0.62	1.13	2.02	3.17	4.26	5.21	6.0		
		4T	0.4	10			0.05	0.14	0.26	0.41	0.79	1.36	2.08	2.83	3.45	4.0		
		5T	0.3	7			0.03	0.08	0.13	0.21	0.39	0.69	1.07	1.43	1.74	2.2		
2"	50	FT	1.7	43.9	0.8	20	1.21	2.46	3.31	5.12	9.42	16.83	26.55	36.59	44.52	49.0		
		1T	1.3	33.4			0.32	0.82	1.51	2.87	5.48	9.31	13.77	18.31	23.17	28.0		
		2T	0.8	21.5			0.17	0.47	0.88	1.63	3.18	5.47	8.21	11.09	13.68	17.0		
		3T	0.6	16			0.15	0.37	0.66	1.02	1.89	3.29	5.01	6.71	8.41	10.0		
		FT	2.8	72			1.5	40	2.01	4.47	7.37	12.28	22.52	38.62	62.02	79.57	90.09	100.0
		1T	1.9	47					1.00	2.51	4.50	6.96	12.95	23.65	36.15	47.82	58.70	70.0
2T	1.3	34	0.73	1.61	2.64	3.95			7.53	13.57	21.26	28.97	34.99	42.0				
3T	1	25	0.36	0.89	1.59	2.46			4.51	8.08	12.55	16.82	20.78	25.0				
FT	3.6	91.5	1.5	40	2.90	6.72			11.48	17.16	29.35	56.26	86.65	120.90	153.84	190.0		
1T	2.4	60			1.56	3.77			6.63	10.11	18.42	32.83	55.27	77.53	98.63	120.0		
2T	1.7	43			1.45	3.05	4.82	8.10	14.86	24.20	35.22	49.81	61.14	72.0				
FT	1.3	32			0.88	1.82	2.84	4.44	8.42	14.38	21.12	27.79	34.17	42.0				

## NOTE

Cv: Valve flow coefficient

FL: Liquid pressure recovery factor

FT: Full capacity 1T: 1-Step reduction

2T: 2-Step reduction 3T: 3-Step reduction

4T: 4-Step reduction 5T: 5-Step reduction

6T: 6-Step reduction

## AB Series Cv vs Travel (General plug)

Size: 2" ... 16"

Flow characteristic: linear

Valve travel [%]							10	20	30	40	50	60	70	80	90	100
F <sub>L</sub>							0.890	0.887	0.884	0.881	0.878	0.875	0.872	0.869	0.867	0.835
Valve size		Orifice diameter			Travel		Rated Cv									
Inch	mm	Sign	Inch	mm	Inch	mm										
2	50	FC	2.5	64.5	1.6	40	8.1	16.1	24.1	32.2	40.2	48.2	56.3	64.3	72.3	82
		1A					7.3	14.5	21.8	29.0	36.3	43.5	50.8	58.0	65.3	74
		2A					4.3	8.6	12.9	17.3	21.6	25.9	30.2	34.5	38.8	44
		3A					2.6	5.1	7.6	10.2	12.7	15.3	17.8	20.4	22.9	26
3	80	FC	3.5	89.0	2	50	17.1	34.1	51.2	68.2	85.3	102.3	119.4	136.5	153.5	174
		1A					10.2	20.4	30.6	40.8	51.0	61.2	71.4	81.6	91.7	104
		2A					6.1	12.2	18.2	24.3	30.4	36.5	42.5	48.6	54.7	62
		3A					3.9	7.8	11.8	15.7	19.6	23.5	27.4	31.4	35.3	40
4	100	FC	4.4	111.5	2	50	27.5	54.9	82.4	109.8	137.3	164.7	192.1	219.6	247.0	280
		1A					16.7	33.4	50.0	66.7	83.3	100.0	116.7	133.3	150.0	170
		2A					9.8	19.6	29.4	39.2	49.0	58.8	68.6	78.4	88.2	100
		3A					6.3	12.6	18.8	25.1	31.4	37.6	43.9	50.2	56.5	64
6	150	FC	5.3	133.6	2.4	60	46.2	92.2	138.3	184.3	230.4	276.5	322.5	368.6	414.6	470
		1A					27.9	55.7	83.6	111.4	139.2	167.0	194.9	222.7	250.5	284
		2A					16.7	33.4	50.0	66.7	83.3	100.0	116.7	133.3	150.0	170
		3A					9.8	19.6	29.4	39.2	49.0	58.8	68.6	78.4	88.2	100
8	200	FC	6.9	175.5	2.8	70	79.5	158.9	238.3	317.7	397.1	476.4	555.8	635.2	714.6	810
		1A					49.1	98.1	147.1	196.1	245.1	294.1	343.1	392.1	441.1	500
		2A					31.4	62.8	94.1	125.5	156.9	188.2	219.6	250.9	282.3	320
		3A					19.6	39.2	58.8	78.4	98.0	117.6	137.2	156.8	176.4	200
10	250	FC	8.4	214.2	3.1	80	122.8	245.3	367.8	490.3	612.8	735.3	857.8	980.3	1102.8	1250
		1A					74.6	149.1	223.6	298.1	372.6	447.0	521.5	596.0	670.5	760
		2A					45.2	90.3	135.3	180.4	225.5	270.6	315.7	360.7	405.8	460
		3A					27.5	54.9	82.4	109.8	137.3	164.7	192.1	219.6	247.0	280
12	300	FC	10.4	264.8	3.9	120	177.7	355.1	532.5	709.9	887.3	1064.6	1242.0	1419.4	1596.8	1810
		1A					108.0	215.8	323.6	431.4	539.2	647.0	754.8	862.6	970.4	1100
		2A					66.8	133.4	200.1	266.7	333.3	400.0	466.6	533.3	599.9	680
		3A					41.2	82.4	123.6	164.7	205.9	247.0	288.2	329.4	370.5	420
14	350	FC	12.4	315.5	4.7	140	248.4	496.4	744.3	992.3	1240.2	1488.1	1736.1	1984.0	2232.0	2530
		1A					150.9	302.1	453.1	604.0	754.9	905.8	1056.7	1207.7	1358.6	1540
		2A					92.1	184.4	276.5	368.7	460.8	552.9	645.0	737.1	829.3	940
		3A					56.9	113.8	170.6	227.5	284.3	341.2	398.0	454.8	511.7	580
16	400	FC	14.1	357.7	5.5	160	290.1	580.8	870.8	1160.9	1451.0	1741.1	2031.2	2321.2	2611.3	2960
		1A					174.5	349.2	523.7	698.1	872.6	1047.0	1221.4	1395.9	1570.3	1780
		2A					105.9	211.9	317.7	423.6	529.4	635.3	741.1	846.9	952.8	1080
		3A					64.7	129.5	194.2	258.9	323.5	388.2	452.9	517.6	582.3	660
18	450	FC	14.7	374	7	180	230.4	605.8	1087.1	1521.3	1871.6	2183.8	2377	2514.7	2634.9	2700
		1A					125.8	343.4	556.4	763.8	967.6	1169.7	1368	1559.4	1737.2	1900
		2A					86.1	225.7	338.6	451.4	564.3	677.2	790	902.9	1015.7	1140
		3A					56.3	134.6	202	269.3	336.6	403.9	471.2	538.6	605.9	680
20	500	FC	19.6	498	9.4	240	350	880	1500	2200	2860	3425	3900	4270	4560	4700
		1A					175	438	730	1035	1325	1600	1870	2125	2370	2500
		2A					93	245	410	585	755	925	1085	1250	1405	1500
		3A					55	150	245	350	450	545	645	740	835	900
24	600	FC	23.5	598	11	280	715	2025	3120	4010	4720	5285	5740	6050	6300	6400
		1A					205	620	1060	1525	1960	2365	2750	3105	3430	3700
		2A					120	385	650	925	1185	1440	1685	1925	2150	2350
		3A					50	200	355	510	665	810	960	1100	1245	1350

NOTE  
 Cv: Valve flow coefficient  
 FL: Liquid pressure recovery factor  
 FC: Full capacity      1A: 1-Step reduction  
 2A: 2-Step reduction      3A: 3-Step reduction

## AB Series Cv vs Travel (General plug)

Size: 2" ... 16"

Flow characteristic: EQ%

Valve travel [%]							10	20	30	40	50	60	70	80	90	100
F <sub>L</sub>							0.890	0.890	0.889	0.888	0.887	0.883	0.878	0.872	0.868	0.840
Valve size		Orifice diameter			Travel		Rated Cv									
Inch	mm	Sign	Inch	mm	Inch	mm										
2	50	FC	2.5	64.5	1.6	40	2.3	3.3	4.9	8.4	15.2	25.1	41.0	57.8	68.4	76
		1A					1.4	2.0	3.0	5.1	9.2	15.2	24.8	35.0	41.4	46
		2A					0.8	1.2	1.8	3.1	5.6	9.2	15.1	21.3	25.2	28
		3A					0.5	0.8	1.2	2.0	3.6	5.9	9.7	13.7	16.2	18
3	80	FC	3.5	89.0	2	50	4.8	7.0	10.4	17.6	32.0	52.8	86.4	121.6	144.0	160
		1A					2.9	4.3	6.4	10.8	19.6	32.3	52.9	74.5	88.2	98
		2A					1.8	2.6	3.9	6.6	12.0	19.8	32.4	45.6	54.0	60
		3A					1.1	1.6	2.3	4.0	7.2	11.9	19.4	27.4	32.4	36
4	100	FC	4.4	111.5	2	50	7.7	11.3	16.6	28.2	51.2	84.5	138.2	194.6	230.4	256
		1A					4.7	6.9	10.1	17.2	31.2	51.5	84.2	118.6	140.4	156
		2A					2.8	4.1	6.1	10.3	18.8	31.0	50.8	71.4	84.6	94
		3A					1.8	2.6	3.9	6.6	12.0	19.8	32.4	45.6	54.0	60
6	150	FC	5.3	133.6	2.4	60	12.9	18.9	28.0	47.3	86.0	141.9	232.2	326.8	387.0	430
		1A					7.8	11.4	16.9	28.6	52.0	85.8	140.4	197.6	234.0	260
		2A					4.7	6.9	10.1	17.2	31.2	51.5	84.2	118.6	140.4	156
		3A					2.9	4.2	6.2	10.6	19.2	31.7	51.8	73.0	86.4	96
8	200	FC	6.9	175.5	2.8	70	22.2	32.6	48.1	81.4	148.0	244.2	399.6	562.4	666.0	740
		1A					13.5	19.8	29.3	49.5	90.0	148.5	243.0	342.0	405.0	450
		2A					8.1	11.9	17.6	29.7	54.0	89.1	145.8	205.2	243.0	270
		3A					4.9	7.2	10.7	18.0	32.8	54.1	88.6	124.6	147.6	164
10	250	FC	8.4	214.2	3.1	80	34.2	50.2	74.1	125.4	228.0	376.2	615.6	866.4	1026.0	1140
		1A					20.4	29.9	44.2	74.8	136.0	224.4	367.2	516.8	612.0	680
		2A					12.3	18.0	26.7	45.1	82.0	135.3	221.4	311.6	369.0	410
		3A					7.5	11.0	16.3	27.5	50.0	82.5	135.0	190.0	225.0	250
12	300	FC	10.4	264.8	3.9	120	49.5	72.6	107.3	181.5	330.0	544.5	891.0	1254.0	1485.0	1650
		1A					30.0	44.0	65.0	110.0	200.0	330.0	540.0	760.0	900.0	1000
		2A					19.2	28.2	41.6	70.4	128.0	211.2	345.6	486.4	576.0	640
		3A					11.5	16.9	25.0	42.2	76.8	126.7	207.4	291.8	345.6	384
14	350	FC	12.4	315.5	4.7	140	69.0	101.2	149.5	253.0	460.0	759.0	1242.0	1748.0	2070.0	2300
		1A					42.0	61.6	91.0	154.0	280.0	462.0	756.0	1064.0	1260.0	1400
		2A					25.2	37.0	54.6	92.4	168.0	277.2	453.6	638.4	756.0	840
		3A					15.6	22.9	33.8	57.2	104.0	171.6	280.8	395.2	468.0	520
16	400	FC	14.1	357.7	5.5	160	81.0	118.8	175.5	297.0	540.0	891.0	1458.0	2052.0	2430.0	2700
		1A					49.2	72.2	106.6	180.4	328.0	541.2	885.6	1246.4	1476.0	1640
		2A					29.4	43.1	63.7	107.8	196.0	323.4	529.2	744.8	882.0	980
		3A					18.0	26.4	39.0	66.0	120.0	198.0	324.0	456.0	540.0	600
18	450	FC	14.7	374	7	180	45.3	129.7	215.7	346.7	608.5	1097.2	1634.3	2072	2469.5	2700
		1A					29.8	82.6	135.2	198.7	324.6	540.3	874.3	1272.8	1620	1900
		2A					27.8	56.6	76.1	117.8	217	387.6	611.5	842.8	1025.5	1140
		3A					16.6	33.8	45.4	70.3	129.4	231.2	364.8	502.7	611.7	680
20	500	FC	19.6	498	9.4	240	80	210	435	895	1690	2670	3480	4105	4540	4700
		1A					50	135	227	400	685	1080	1475	1845	2200	2500
		2A					28	80	135	195	320	568	830	1085	1330	1500
		3A					17	60	110	180	275	395	530	665	795	900
24	600	FC	23.5	598	11	280	100	390	860	1700	3010	4250	5140	5750	6135	6400
		1A					55	215	400	670	1055	1595	2205	2765	3275	3700
		2A					30	150	315	535	805	1135	1480	1815	2130	2350
		3A					20	105	205	340	500	685	880	1075	1265	1350

## NOTE

Cv: Valve flow coefficient

FL: Liquid pressure recovery factor

FC: Full capacity      1A: 1-Step reduction

2A: 2-Step reduction      3A: 3-Step reduction

## AB Series Cv vs Travel (Tendril 1)

Size: 2" ... 16"

Flow characteristic: linear

Valve travel [%]							10	20	30	40	50	60	70	80	90	100	
F <sub>L</sub>							0.912	0.915	0.917	0.920	0.923	0.926	0.929	0.930	0.925	0.920	
Valve size		Orifice diameter			Travel		Rated Cv										
Inch	mm	Sign	Inch	mm	Inch	mm											
2	50	FC	2.5	64.5	1.6	40	3.0	11.8	19.7	26.6	33.2	39.0	43.8	47.7	50.8	52	
		1A					1.9	7.7	13.0	17.7	22.4	26.8	31.0	34.8	38.3	40	
		2A					1.2	4.8	8.1	11.2	14.3	17.2	20.1	22.8	25.4	27	
		3A					0.4	1.7	2.9	4.0	5.2	6.3	7.4	8.5	9.6	10	
3	80	FC	3.5	89.0	2	50	7.5	23.0	36.9	49.9	61.9	73.2	82.9	91.2	98.0	102	
		1A					4.7	14.6	23.7	32.4	40.6	48.8	56.4	63.6	70.4	75	
		2A					2.4	7.6	12.4	17.1	21.7	26.2	30.5	34.8	38.9	40	
		3A					1.2	3.9	6.4	8.9	11.3	13.8	16.1	18.4	20.7	21	
4	100	FC	4.4	111.5	2	50	8.5	32.6	55.1	75.9	95.6	113.8	130.5	144.6	156.2	160	
		1A					5.3	20.4	34.8	48.3	61.5	74.1	86.7	98.5	109.6	120	
		2A					2.9	11.3	19.5	27.3	34.9	42.4	49.9	57.1	64.2	70	
		3A					1.9	7.6	13.2	18.5	23.8	28.9	34.2	39.2	44.1	46	
6	150	FC	5.3	133.6	2.4	60	13.8	54.4	95.1	134.3	170.9	204.3	234.1	259.9	281.9	290	
		1A					9.0	35.2	61.8	88.2	114.1	139.2	163.1	185.7	206.9	220	
		2A					4.9	18.9	33.1	47.3	61.6	75.9	90.1	104.1	117.9	130	
		3A					2.9	10.8	18.8	26.9	35.0	43.2	51.4	59.5	67.7	75	
8	200	FC	6.9	175.5	2.8	70	19.7	87.1	152.3	213.7	271.5	323.2	368.8	409.4	444.2	460	
		1A					12.7	56.0	98.8	140.5	181.6	220.5	257.3	292.4	324.9	340	
		2A					6.4	28.0	49.5	70.8	92.4	113.6	134.4	155.2	175.5	195	
		3A					3.6	15.6	27.5	39.3	51.4	63.3	75.1	87.1	99.0	105	
10	250	FC	8.4	214.2	3.1	80	39.7	122.6	206.9	287.7	361.2	430.8	493.5	548.0	597.7	630	
		1A					25.7	78.3	132.7	186.4	237.5	288.4	337.1	382.2	426.0	460	
		2A					14.2	41.5	69.9	98.4	126.0	154.4	182.4	209.4	236.8	255	
		3A					8.4	23.2	38.6	54.1	69.1	84.6	100.2	115.3	130.8	140	
12	300	FC	10.4	264.8	3.9	120	76.8	216.1	351.6	478.6	594.1	696.7	786.2	863.1	928.4	980	
		1A					48.9	136.8	224.6	310.8	394.0	473.3	548.1	617.8	682.3	735	
		2A					25.2	68.8	112.8	156.8	200.8	244.4	287.5	330.0	371.7	405	
		3A					15.4	40.7	66.1	91.7	117.4	143.1	168.8	194.5	220.0	240	
14	350	FC	12.4	315.5	4.7	140	89.2	275.6	460.6	634.1	789.1	929.1	1050.3	1151.4	1237.4	1300	
		1A					56.5	174.0	293.5	410.7	521.9	629.9	731.6	824.7	912.3	985	
		2A					29.7	90.1	152.1	214.2	274.8	336.1	396.5	454.9	513.1	565	
		3A					16.4	48.4	81.3	114.3	146.8	179.9	212.9	245.3	278.2	310	
16	400	FC	14.1	357.7	5.5	160	121.6	332.6	546.9	756.9	949.0	1121.7	1274.6	1402.5	1508.5	1580	
		1A					73.6	198.0	326.6	458.4	586.9	712.2	834.3	948.3	1055.2	1145	
		2A					41.5	108.3	177.2	248.6	319.8	391.4	464.1	535.3	605.7	670	
		3A					26.9	68.0	110.1	153.6	197.1	241.1	286.2	330.8	375.6	415	
18	450	FC	14.7	374	7	180	161.6	442.0	726.9	1,006.0	1,261.3	1,490.8	1,694.1	1,864.0	2,004.9	2,100.0	
		1A					93.2	250.7	413.6	580.5	743.2	901.9	1,056.5	1,200.8	1,336.2	1,450.0	
		2A					53.9	140.6	230.1	322.7	415.2	508.2	602.6	695.1	786.5	870.0	
		3A					33.7	85.2	137.9	192.5	247.0	302.2	358.6	414.5	470.7	520.0	
20	500	FC	19.6	498	9.4	240	215.4	589.3	969.2	1,341.4	1,681.7	1,987.8	2,258.8	2,485.4	2,673.2	2,800.0	
		1A					128.6	345.8	570.4	800.6	1,025.2	1,244.0	1,457.2	1,656.3	1,843.1	2,000.0	
		2A					74.3	194.0	317.3	445.2	572.7	701.0	831.2	958.7	1,084.8	1,200.0	
		3A					46.6	118.0	191.0	266.5	342.0	418.4	496.6	574.0	651.7	720.0	
24	600	FC	23.5	598	11	280	307.7	841.9	1,384.6	1,916.3	2,402.5	2,839.7	3,226.8	3,550.5	3,818.9	4,000.0	
		1A					180.1	484.1	798.6	1,120.9	1,435.2	1,741.6	2,040.1	2,318.9	2,580.3	2,800.0	
		2A					105.3	274.8	449.5	630.6	811.3	993.1	1,177.6	1,358.1	1,536.8	1,700.0	
		3A					64.8	163.9	265.3	370.1	475.0	581.1	689.7	797.2	905.1	1,000.0	

## AB Series Cv vs Travel (Tendril 1)

Size: 2" ... 16"

Flow characteristic: EQ%

Valve travel [%]							10	20	30	40	50	60	70	80	90	100
F <sub>L</sub>							0.912	0.912	0.913	0.915	0.916	0.919	0.922	0.930	0.925	0.922
Valve size		Orifice diameter			Travel		Rated Cv									
Inch	mm	Sign	Inch	mm	Inch	mm										
2	50	FC	2.5	64.5	1.6	40	0.4	2.4	4.4	8.1	13.7	20.5	28.3	36.4	44.1	50
		1A					0.4	2.4	4.2	5.9	9.5	14.6	20.4	25.7	30.7	35
		2A					0.2	1.0	2.3	4.0	6.2	8.9	11.9	14.8	17.7	20
		3A					0.2	1.0	2.2	3.4	4.5	5.7	6.8	7.9	9.0	10
3	80	FC	3.5	89.0	2	50	0.7	2.7	6.3	12.5	20.9	31.5	43.6	57.0	71.1	82
		1A					0.7	2.7	4.7	8.5	14.8	23.6	33.3	42.5	51.3	58
		2A					0.7	2.7	4.7	8.5	13.3	18.1	22.6	27.1	31.3	35
		3A					0.3	1.4	3.1	5.5	8.0	10.5	12.9	15.3	17.6	20
4	100	FC	4.4	111.5	2	50	1.0	5.2	9.5	17.1	30.3	48.2	71.3	95.5	117.5	135
		1A					0.5	2.6	6.3	13.0	22.3	34.2	48.8	65.1	82.1	95
		2A					0.5	2.6	4.8	8.7	15.6	24.6	33.8	42.5	51.1	58
		3A					0.5	2.6	4.8	8.5	12.6	16.6	20.7	24.6	28.5	32
6	150	FC	5.3	133.6	2.4	60	1.6	7.5	16.2	33.1	58.4	91.7	131.8	172.1	208.6	235
		1A					1.6	7.5	13.4	22.2	39.2	64.5	92.9	120.7	147.3	170
		2A					0.9	3.8	6.8	11.1	19.5	32.0	48.7	67.1	85.4	100
		3A					0.9	3.8	6.8	11.1	18.8	26.9	35.0	43.2	51.4	58
8	200	FC	6.9	175.5	2.8	70	1.5	12.8	35.3	68.6	113.2	167.1	227.7	288.0	341.3	370
		1A					1.5	8.5	21.5	45.3	80.7	122.9	163.9	204.1	242.0	265
		2A					0.8	4.3	10.8	22.6	40.3	63.6	91.9	122.8	152.7	170
		3A					0.8	4.3	8.0	15.1	28.0	44.6	61.2	78.0	94.6	105
10	250	FC	8.4	214.2	3.1	80	4.2	19.1	48.4	91.6	147.0	216.6	295.8	370.8	441.5	500
		1A					4.2	12.2	31.1	63.9	109.2	165.6	221.2	273.6	325.3	370
		2A					4.2	12.2	21.5	43.8	73.9	105.0	136.0	166.0	196.5	225
		3A					2.9	6.8	11.5	22.6	39.3	57.3	75.4	93.0	111.1	125
12	300	FC	10.4	264.8	3.9	120	7.4	26.7	75.3	153.7	260.7	391.7	527.8	648.9	754.0	840
		1A					7.4	18.8	52.7	116.3	202.8	289.5	373.5	453.9	529.8	600
		2A					4.5	10.2	27.1	58.6	104.8	156.2	207.5	258.3	308.3	355
		3A					4.5	10.2	27.1	52.5	78.0	103.7	129.4	155.1	180.7	205
14	350	FC	12.4	315.5	4.7	140	6.7	30.7	93.6	195.6	332.7	504.5	687.7	849.2	992.0	1110
		1A					6.7	21.0	67.3	152.6	264.7	378.6	489.2	593.3	693.8	785
		2A					4.0	11.1	34.1	76.5	137.3	207.6	277.7	345.7	414.0	480
		3A					4.0	11.1	34.1	70.6	107.0	144.2	181.4	217.9	255.1	290
16	400	FC	14.1	357.7	5.5	160	9.4	44.5	125.3	258.1	439.8	664.3	890.8	1090.8	1263.7	1400
		1A					9.4	30.8	94.0	207.6	349.8	493.0	635.9	771.9	901.1	1020
		2A					6.1	16.7	47.8	102.8	180.1	263.7	349.8	434.9	519.6	600
		3A					6.1	16.7	47.8	90.1	132.6	175.8	220.2	264.5	309.0	350
18	450	FC	14.7	374	7	180	12.7	60.4	170.1	350.2	596.8	901.6	1,209.0	1,480.4	1,715.0	1,900.0
		1A					12.0	39.2	119.8	264.6	445.8	628.3	810.5	983.8	1,148.5	1,300.0
		2A					9.1	25.0	72.0	133.6	234.1	342.8	454.7	565.3	675.5	780.0
		3A					8.2	25.0	64.2	120.9	178.0	236.1	295.8	355.1	415.0	470.0
20	500	FC	19.6	498	9.4	240	16.8	79.5	223.8	460.8	785.3	1,186.3	1,590.8	1,947.9	2,256.6	2,500.0
		1A					16.6	54.3	165.9	366.3	617.2	869.9	1,122.2	1,362.2	1,590.2	1,800.0
		2A					12.8	35.0	100.0	188.5	330.1	483.5	641.3	797.3	952.6	1,100.0
		3A					11.3	34.0	88.7	167.2	246.2	326.5	409.0	491.1	573.9	650.0
24	600	FC	23.5	598	11	280	24.1	114.5	322.2	663.6	1,130.9	1,708.2	2,290.7	2,805.0	3,249.4	3,600.0
		1A					23.5	76.9	235.0	519.0	874.4	1,232.4	1,589.9	1,929.8	2,252.8	2,550.0
		2A					18.1	49.3	140.9	265.6	465.1	681.3	903.6	1,123.4	1,342.4	1,550.0
		3A					15.7	47.1	122.9	231.6	340.9	452.0	566.3	680.0	794.6	900.0

NOTE  
 Cv: Valve flow coefficient  
 FL: Liquid pressure recovery factor  
 FC: Full capacity      1A: 1-Step reduction  
 2A: 2-Step reduction      3A: 3-Step reduction

## AB Series Cv vs Travel (Tendril 2)

Size: 2" ... 24"

Flow characteristic: Linear

Valve travel [%]							10	20	30	40	50	60	70	80	90	100
F <sub>L</sub>							0.922	0.925	0.928	0.931	0.934	0.937	0.938	0.94	0.936	0.932
Valve size		Orifice diameter			Travel		Rated Cv									
Inch	mm	Sign	Inch	mm	Inch	mm										
2	50	FC	2.5	64.5	1.6	40	2.9	10.7	17.7	24.2	30.1	35.5	40.3	44.4	47.7	50.0
		1A					1.7	6.2	10.4	14.4	18.2	21.8	25.3	28.6	31.8	35.0
		2A					1.0	3.8	6.5	9.0	11.5	13.9	16.2	18.4	20.6	23.0
		3A					0.4	1.3	2.3	3.2	4.1	5.0	5.9	6.8	7.6	8.0
3	80	FC	3.5	89	2	50	7.7	22.4	36.0	48.5	60.4	71.2	80.9	89.2	96.2	100.0
		1A					4.9	14.5	23.5	31.9	40.1	47.9	55.4	62.6	69.3	74.0
		2A					2.0	6.0	9.9	13.7	17.4	21.0	24.5	27.9	31.3	33.0
		3A					1.0	3.1	5.1	7.1	9.0	10.9	12.8	14.7	16.5	18.0
4	100	FC	4.4	111.5	2	50	8.4	30.4	50.7	70.3	88.6	105.9	121.7	135.9	148.0	155.0
		1A					5.7	20.6	34.7	48.4	61.4	74.2	86.4	98.2	109.3	115.0
		2A					2.8	10.5	17.9	25.2	32.2	39.1	45.9	52.6	59.1	65.0
		3A					1.6	6.1	10.4	14.7	18.8	23.0	27.1	31.1	35.1	38.0
6	150	FC	5.3	133.6	2.4	60	13.9	49.6	85.4	120.4	153.7	184.6	212.9	238.3	260.7	280.0
		1A					9.8	34.6	59.7	84.8	109.4	133.3	156.3	178.1	198.6	215.0
		2A					5.2	18.1	31.1	44.2	57.4	70.6	83.7	96.6	109.5	120.0
		3A					2.9	9.9	16.9	24.0	31.1	38.3	45.4	52.6	59.8	67.0
8	200	FC	6.9	175.5	2.8	70	18.9	74.7	130.1	183.2	233.6	280.3	323.3	362.1	397.0	425.0
		1A					13.3	52.3	91.5	129.9	167.5	203.6	238.4	271.2	302.3	330.0
		2A					7.2	28.0	49.1	70.0	91.0	111.6	132.2	152.3	172.3	190.0
		3A					3.9	15.0	26.2	37.3	48.6	59.7	70.9	82.1	93.2	100.0
10	250	FC	8.4	214.2	3.1	80	36.1	109.6	182.6	253.6	321.1	384.4	442.8	496.3	544.7	590.0
		1A					25.4	76.3	127.3	178.0	227.6	275.8	322.2	366.6	408.7	450.0
		2A					13.4	38.7	64.1	89.6	115.2	140.6	166.0	191.1	215.9	240.0
		3A					7.8	21.1	34.5	47.9	61.4	74.9	88.4	101.9	115.4	130.0
12	300	FC	10.4	264.8	3.9	120	70.4	195.0	317.4	433.7	541.5	639.4	726.8	803.7	870.7	920.0
		1A					48.9	134.7	220.6	304.8	386.4	464.3	537.9	606.7	670.7	720.0
		2A					24.0	64.4	105.2	146.1	186.9	227.5	267.7	307.5	346.5	380.0
		3A					14.6	37.9	61.3	84.8	108.5	132.1	155.8	179.5	203.0	220.0
14	350	FC	12.4	315.5	4.7	140	82.7	253.5	421.0	580.2	727.6	860.9	979.3	1082.4	1171.0	1240.0
		1A					56.1	171.5	286.8	400.0	509.6	614.4	713.5	806.2	892.2	970.0
		2A					29.7	89.5	149.6	209.8	269.8	329.4	388.1	446.0	502.7	550.0
		3A					16.0	46.9	78.0	109.2	140.5	171.8	203.1	234.4	265.6	290.0
16	400	FC	14.1	357.7	5.5	160	114.4	310.6	510.7	705.8	889.4	1057.2	1206.6	1336.4	1446.8	1530.0
		1A					72.5	193.6	318.8	445.4	570.9	693.6	811.7	924.1	1030.0	1130.0
		2A					40.2	104.0	169.8	236.9	305.0	373.5	442.0	510.3	578.0	640.0
		3A					25.7	64.4	104.0	144.2	185.1	226.4	268.2	310.1	352.3	390.0
18	450	FC	14.7	374	7	180	142.1	385.7	634.2	876.5	1104.5	1312.9	1498.4	1659.6	1796.7	1900.0
		1A					86.6	231.3	380.9	532.1	682.1	828.6	969.7	1104.1	1230.5	1350.0
		2A					50.2	130.0	212.2	296.1	381.2	466.8	552.5	637.9	722.5	800.0
		3A					31.6	79.3	127.9	177.5	227.8	278.7	330.0	381.7	433.6	480.0
20	500	FC	19.6	498	9.4	240	186.9	507.5	834.5	1153.3	1453.3	1727.4	1971.5	2183.7	2364.0	2500.0
		1A					112.3	299.8	493.7	689.7	884.2	1074.1	1257.0	1431.2	1595.1	1750.0
		2A					65.9	170.7	278.5	388.7	500.3	612.7	725.2	837.2	948.3	1050.0
		3A					41.5	104.0	167.9	233.0	299.0	365.8	433.2	501.0	569.1	630.0
24	600	FC	23.5	598	11	280	272.9	741.0	1218.4	1683.8	2121.8	2522.1	2878.4	3188.2	3451.5	3650.0
		1A					163.6	436.8	719.4	1005.0	1288.4	1565.1	1831.7	2085.4	2324.3	2550.0
		2A					96.1	248.7	405.9	566.4	729.0	892.8	1056.7	1220.0	1381.8	1530.0
		3A					60.6	151.9	245.2	340.2	436.6	534.2	632.6	731.6	831.0	920.0

NOTE  
 Cv: Valve flow coefficient  
 FL: Liquid pressure recovery factor  
 FC: Full capacity      1A: 1-Step reduction  
 2A: 2-Step reduction      3A: 3-Step reduction

## AB Series Cv vs Travel (Tendril 2)

Size: 2" ... 24"

Flow characteristic: EQ%

Valve travel [%]							10	20	30	40	50	60	70	80	90	100
F <sub>L</sub>							0.922	0.922	0.923	0.925	0.928	0.931	0.934	0.941	0.936	0.934
Valve size		Orifice diameter			Travel		Rated Cv									
Inch	mm	Sign	Inch	mm	Inch	mm										
2	50	FC	2.5	64.5	1.6	40	0.4	1.8	3.8	7.5	12.6	18.8	26.0	33.7	41.3	47.0
		1A					0.4	1.8	3.2	5.2	8.8	13.8	19.0	24.0	28.7	33.0
		2A					0.2	0.9	2.0	3.5	5.5	7.8	10.4	13.4	16.4	19.0
		3A					0.2	0.9	1.8	2.8	3.7	4.6	5.5	6.3	7.2	8.0
3	80	FC	3.5	89	2	50	0.6	2.2	5.7	11.4	19.2	28.7	39.8	52.1	65.2	74.0
		1A					0.6	2.2	3.9	7.8	14.0	22.0	31.8	41.5	50.8	56.0
		2A					0.6	2.2	3.9	7.8	12.6	17.2	21.7	26.1	30.3	33.0
		3A					0.3	1.1	2.7	4.7	6.7	8.6	10.5	12.4	14.3	16.0
4	100	FC	4.4	111.5	2	50	0.8	4.3	11.1	23.1	39.3	59.7	81.2	101.5	119.9	130.0
		1A					0.4	3.4	9.0	17.2	27.6	40.3	54.3	68.2	81.5	92.0
		2A					0.4	2.2	3.9	8.0	14.5	22.9	30.9	38.9	46.6	52.0
		3A					0.4	2.2	3.9	7.2	10.4	13.6	16.8	19.9	23.0	25.0
6	150	FC	5.3	133.6	2.4	60	1.3	8.6	23.1	45.0	74.2	108.9	142.8	174.6	203.8	230.0
		1A					1.3	5.2	15.0	32.0	55.2	79.2	102.7	125.7	147.9	165.0
		2A					0.7	2.7	7.6	15.9	28.0	42.3	56.7	71.0	85.3	95.0
		3A					0.7	2.6	5.1	11.0	18.1	25.2	32.3	39.4	46.6	52.0
8	200	FC	6.9	175.5	2.8	70	1.2	10.7	30.1	59.2	98.1	145.6	198.0	247.2	293.1	330.0
		1A					1.2	6.5	20.2	43.8	77.0	113.0	148.4	182.6	215.8	245.0
		2A					0.7	3.3	10.1	21.9	38.6	59.9	82.3	104.4	126.4	145.0
		3A					0.7	2.8	6.8	15.8	27.0	38.1	49.4	60.5	71.7	80.0
10	250	FC	8.4	214.2	3.1	80	4.6	15.5	44.0	90.9	155.6	226.1	293.7	357.5	416.9	470.0
		1A					3.6	10.8	29.8	60.8	104.1	152.1	199.4	245.6	290.4	330.0
		2A					2.5	9.0	21.4	39.9	64.1	89.6	115.2	140.6	166.0	190.0
		3A					2.5	4.7	11.2	23.6	38.5	53.5	68.4	83.5	98.5	110.0
12	300	FC	10.4	264.8	3.9	120	6.9	35.8	90.7	171.8	277.6	395.8	506.6	607.9	698.8	770.0
		1A					5.0	17.9	55.5	119.2	200.4	280.9	359.3	434.7	506.3	570.0
		2A					3.3	9.8	28.4	60.0	104.1	151.5	198.7	245.6	291.9	330.0
		3A					3.3	9.8	28.3	51.7	75.2	98.8	122.5	146.1	169.8	190.0
14	350	FC	12.4	315.5	4.7	140	6.0	31.3	105.7	231.2	392.6	549.2	695.0	828.1	947.1	1050.0
		1A					4.4	21.2	70.7	154.2	255.2	355.1	452.6	546.9	637.3	720.0
		2A					2.8	11.2	35.8	77.3	134.5	194.7	254.8	314.4	373.4	430.0
		3A					2.8	11.2	35.8	69.2	102.8	136.5	170.2	203.9	237.6	270.0
16	400	FC	14.1	357.7	5.5	160	8.9	47.1	146.4	312.3	509.8	702.4	883.9	1050.2	1198.5	1320.0
		1A					6.8	32.2	97.4	205.7	336.5	468.3	598.6	725.3	846.8	960.0
		2A					4.8	17.4	49.4	101.9	173.1	248.1	324.2	400.7	477.0	550.0
		3A					4.8	17.4	47.8	82.0	116.9	152.3	188.1	224.3	260.7	295.0
18	450	FC	14.7	374	7	180	11.4	60.6	188.5	402.2	656.5	904.6	1138.4	1352.5	1543.6	1700.0
		1A					8.7	40.9	123.7	261.4	427.6	595.1	760.7	921.8	1076.1	1220.0
		2A					7.0	25.4	69.6	133.4	226.6	324.8	424.4	524.5	624.5	720.0
		3A					7.0	25.4	69.6	119.6	170.4	222.0	274.2	326.9	380.1	430.0
20	500	FC	19.6	498	9.4	240	14.8	78.5	244.0	520.5	849.6	1170.7	1473.2	1750.3	1997.6	2200.0
		1A					11.2	52.6	159.2	336.4	550.2	765.8	978.9	1186.2	1384.9	1570.0
		2A					9.3	33.7	92.3	176.0	299.0	428.6	559.9	692.0	824.0	950.0
		3A					9.3	33.7	92.3	158.5	225.9	294.2	363.4	433.4	503.8	570.0
24	600	FC	23.5	598	11	280	22.1	117.7	366.0	780.8	1274.5	1756.0	2209.9	2625.4	2996.4	3300.0
		1A					16.4	77.1	233.3	492.9	806.1	1121.9	1434.1	1737.7	2028.8	2300.0
		2A					13.6	49.0	134.4	252.0	428.1	613.6	801.6	990.7	1179.6	1360.0
		3A					13.6	49.0	134.4	230.8	328.9	428.4	529.2	631.0	733.6	830.0

## NOTE

Cv: Valve flow coefficient

FL: Liquid pressure recovery factor

FC: Full capacity      1A: 1-Step reduction

2A: 2-Step reduction      3A: 3-Step reduction

## A series, Valve dimensions and weights

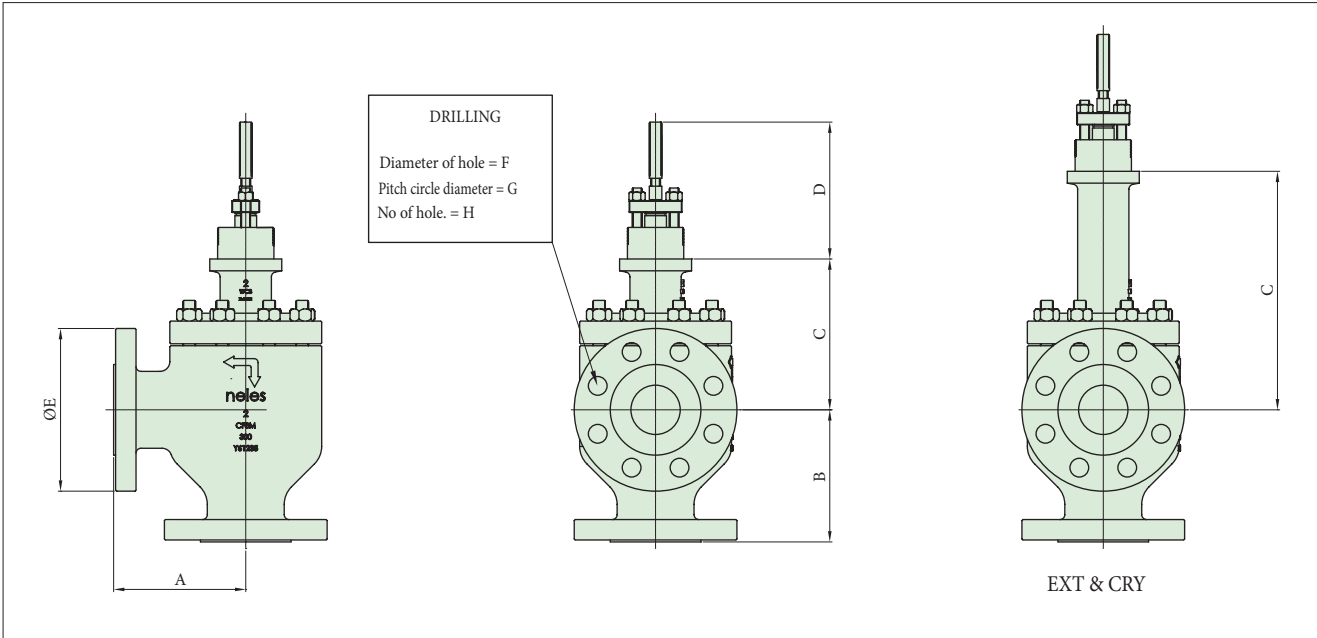

### 150 #/ 300 #/ 600 #

Dimension (mm)	A			B			C			D	E			F			G			H			Weight (kg) (Approximate)		
	150#	300#	600#	150#	300#	600#	STD	EXT	CRY		COMMON	150#	300#	600#	150#	300#	600#	150#	300#	600#	150#	300#	600#	150#	300#
25	92	99	105	92	99	105	142	250	400	110	110	125	125	15.9	19.1	19.1	79.4	88.9	88.9	4	4	4	14	15	23
40	111	118	125	111	118	125	161	269	419	110	125	155	155	15.9	22.2	22.2	98.4	114.3	114.3	4	4	4	22	23	27
50	127	133	143	127	133	143	178	333	458	110	150	165	165	19.1	19.1	19.1	120.7	127	127	4	8	8	25	27	32
80	149	159	168	149	159	168	222	395	545	115	190	210	210	19.1	22.2	22.2	152.4	168.3	168.3	4	8	8	65	67	72
100	176	184	197	176	184	197	248	402	552	140	230	255	275	19.1	22.2	25.4	190.5	200	215.9	8	8	8	100	103	112
150	226	236	254	226	236	254	340	467	642	150	280	320	355	22.2	22.2	28.6	241.3	269.9	292.1	8	12	12	185	195	240
200	272	284	305	272	284	305	451	557	732	150	345	380	420	22.2	25.4	31.8	298.5	330.2	349.2	8	12	12	363	385	443
250	337	354	376	337	354	376	488	670	870	150	405	445	510	25.4	28.6	34.9	362	387.4	431.8	12	16	16	552	595	681
300	369	388	410	369	388	410	543	716	916	150	485	520	560	25.4	31.8	34.9	431.8	450.8	489	12	16	20	905	955	1020
350	445	464	486	445	464	486	616	846	1046	210	535	585	605	28.6	31.8	38.1	476.3	514.4	527	12	20	20	1170	1230	1311
400	508	529	554	508	529	554	692	909	1109	220	595	650	685	28.6	34.9	41.3	539.8	571.5	603.2	16	20	20	1380	1460	1587

Dimension (inch)	A			B			C			D	E			F			G			H			Weight (lbs) (Approximate)		
	150#	300#	600#	150#	300#	600#	STD	EXT	CRY		COMMON	150#	300#	600#	150#	300#	600#	150#	300#	600#	150#	300#	600#	150#	300#
1"	3.6	3.9	4.1	3.6	3.9	4.1	5.6	9.8	15.7	4.3	4.3	4.9	4.9	0.6	0.8	0.8	3.1	3.5	3.5	4	4	4	30.9	33.1	50.7
1-1/2"	4.4	4.6	4.9	4.4	4.6	4.9	6.3	10.6	16.5	4.3	4.9	6.1	6.1	0.6	0.9	0.9	3.9	4.5	4.5	4	4	4	48.5	50.7	59.5
2"	5	5.2	5.6	5	5.2	5.6	7	13.1	18	4.3	5.9	6.5	6.5	0.8	0.8	0.8	4.8	5	5	4	8	8	55.1	59.5	70.5
3"	5.9	6.3	6.6	5.9	6.3	6.6	8.7	15.6	21.5	4.5	7.5	8.3	8.3	0.8	0.9	0.9	6	6.6	6.6	4	8	8	143.3	147.7	158.7
4"	6.9	7.2	7.8	6.9	7.2	7.8	9.8	15.8	21.7	5.5	9.1	10	10.8	0.8	0.9	1	7.5	7.9	8.5	8	8	8	220.5	227.1	246.9
6"	8.9	9.3	10	8.9	9.3	10	13.4	18.4	25.7	5.9	11	12.6	14	0.9	0.9	1.1	9.5	10.6	11.5	8	12	12	407.9	429.9	529.1
8"	10.7	11.2	12	10.7	11.2	12	17.8	21.9	28.8	5.9	13.6	15	16.5	0.9	1	1.3	11.8	13	13.7	8	12	12	800.3	848.8	976.6
10"	13.3	13.9	14.8	13.3	13.9	14.8	19.2	26.4	34.3	5.9	15.9	17.5	20.1	1	1.1	1.4	14.3	15.3	17	12	16	16	1217	1311.8	1501.3
12"	15	15.3	16.1	14.5	15.3	16.1	21.4	28.2	36.1	5.9	19.1	20.5	22	1	1.3	1.4	17	17.7	19.3	12	16	20	1995.2	2105.4	2248.7
14"	18	18.3	19.1	17.5	18.3	19.1	24.3	33.3	41.2	8.3	21.1	23	23.8	1.1	1.3	1.5	18.8	20.3	20.7	12	20	20	2579.4	2711.7	2890.3
16"	20	20.8	21.8	20	20.8	21.8	27.2	35.8	43.7	8.7	23.4	25.6	27	1.1	1.4	1.6	21.3	22.5	23.7	16	20	20	3042.4	3218.7	3498.7

900 #/ 1500 #

Dimension (mm)	A		B		C		D	E		F		G		H		Weight (kg) (Approximate)	
	900#	1500#	900#	1500#	STD	EXT	COMMON	900#	1500#	900#	1500#	900#	1500#	900#	1500#	900#	1500#
25	146	146	146	146	229	330	110	150	150	25.4	25.4	101.6	101.6	4	4	44	46
40	167	167	167	167	278	380	110	180	180	28.6	28.6	123.8	123.8	4	4	63	63
50	188	188	188	188	300	400	110	215	215	25.4	25.4	165.1	165.1	8	8	67	67
80	221	230	221	230	330	430	115	240	265	25.4	31.8	190.5	203.2	8	8	150	163
100	256	265	256	265	350	450	140	290	310	31.8	34.9	235	241.3	8	8	244	255
150	357	384	357	384	393	500	150	380	395	31.8	38.1	317.5	317.5	12	12	530	540
200	457	486	457	486	480	600	150	470	485	38.1	44.5	393.7	393.7	12	12	698	821
250	496	534	496	534	518	650	150	545	585	38.1	50.8	469.9	482.6	16	12	955	1137
300	565	610	565	610	680	800	150	610	675	38.1	54	533.4	571.5	20	16	1180	1240
350	629	629	629	629	770	920	210	640	750	41.3	60.3	558.8	635	20	16	1387	1477
400	711	711	711	711	850	1050	220	705	825	44.5	66.7	616	704.8	20	16	1601	1721

Dimension (inch)	A		B		C		D	E		F		G		H		Weight (lbs) (Approximate)	
	900#	1500#	900#	1500#	STD	EXT	COMMON	900#	1500#	900#	1500#	900#	1500#	900#	1500#	900#	1500#
1"	5.7	5.7	5.7	5.7	9	13	4.3	5.9	5.9	1	1	4	4	4	4	97	101.4
1-1/2"	6.6	6.6	6.6	6.6	11	15	4.3	7.1	7.1	1.1	1.1	4.9	4.9	4	4	138.9	138.9
2"	7.4	7.4	7.4	7.4	12	16	4.3	8.5	8.5	1	1	6.5	6.5	8	8	147.7	147.7
3"	8.7	9.1	8.7	9.1	13	17	4.5	9.4	10.4	1	1.3	7.5	8	8	8	330.7	359.4
4"	10.1	10.4	10.1	10.4	14	18	5.5	11.4	12.2	1.3	1.4	9.3	9.5	8	8	537.9	562.2
6"	14.1	15.1	14.1	15.1	15	20	5.9	15	15.6	1.3	1.5	12.5	12.5	12	12	1168.4	1190.5
8"	18	19.1	18	19.1	19	24	5.9	18.5	19.1	1.5	1.8	15.5	15.5	12	12	1538.8	1810
10"	20	21	19.5	21	20	26	5.9	21.5	23	1.5	2	18.5	19	16	12	2105.4	2506.7
12"	22.2	24	22.2	24	27	31	5.9	24	26.6	1.5	2.1	21	22.5	20	16	2601.5	2733.7
14"	24.8	24.8	24.8	24.8	30	36	8.3	25.2	29.5	1.6	2.4	22	25	20	16	3057.8	3256.2
16"	28	28	28	28	33	41	8.7	27.8	32.5	1.8	2.6	24.3	27.7	20	16	3529.6	3794.2

\*Bigger sizes and higher ratings are available, please contact sales office for more information

## How to order

### Angle unbalanced, top guided type, series AU

1.	2.	3.	4.	5.	6.	7.	8.	9.	10.	11.	12.	13.	14.	15.	16.	17.	18.	19.	20.	21.	22.
AU	01	C	W	A	J2	B	P1	X	BC	S1	R1	X	S	G	X	S	G	X	A	E	FC

### Valve constructions

1.	Valve series
AU	Angle unbalanced, top guided type

2.	Body size			
0H	0.5" / DN 15	3Q	0.75" / DN 20	
01	1" / DN 25	1H	1.5" / DN 40	
02	2" / DN 50	03	3" / DN 80	
04	4" / DN 100	06	6" / DN 150	
Y	Special			

3.	Pressure rating			
C	ASME class 150	D	ASME class 300	
F	ASME class 600	G	ASME class 900	
H	ASME class 1500	I	ASME class 2500	
J	EN PN 10	K	EN PN 16	
L	EN PN 25	M	EN PN 40	
N	EN PN 63	P	EN PN 100	
B	EN PN 160	E	EN PN 250	
Y	EN PN 320			

4.	End connection			
W	Flanged RF, ASME B16.5			
Z	Ring joint flange, ASME B16.5			
V	Socket welding, ASME B16.11			
Q	Butt welding, ASME B16.25			
Y	Special			

5.	Bonnet construction	
	Bonnet type	Actuator connection
A	General	Applicable for VD_25/29/37
B	General	Applicable for VD_48/55
C	General	Applicable for VC_30, VB_32
D	General	Applicable for VC/VB_40/50/60/70
E	Extension	Applicable for VD_25/29/37
F	Extension	Applicable for VD_48/55
G	Extension	Applicable for VC_30, VB_32
H	Extension	Applicable for VC/VB_40/50/60/70
P	Cryogenic	Applicable for VD_25/29/37
Q	Cryogenic	Applicable for VD_48/55
R	Cryogenic	Applicable for VC_30, VB_32
S	Cryogenic	Applicable for VC/VB_40/50/60/70
Y	Bellows seals	Applicable for VD_25/29/37

6.	Body material			
J2	A216 gr. WCB			
S6	A351 gr. CF8M			
J4	A217 gr. WC6			
CG	A217 gr. WC9			
S1	A351 gr. CF3M			
YY	Special			

- Bonnet material is equivalent to body material.

7.	Model code			
B	Model B			

### Trim constructions

8.	Plug material	
	Material	Description
P1	410 SS	General for carbon steel valve
T6	316 SS	General for stainless steel valve
VM	Alloy 6	Use for small Cv and micro trim
P2	420J2	General for Cr-Mo valve
S1	316L SS	
YY	Special	Special materials

9.	Plug application	
X	Not applicable	
A	Cobalt based alloy	
Y	Special	

10.	Stem material	
	Material	Description
BC	630 SS + HCr	General for carbon steel valve
TC	316 SS + HCr	General for stainless steel valve
VX	XM-19	General for Cr-Mo valve
FC	316L SS + HCr	

11.	Seat type		
S1	Single metal seat		
T1	Single soft seat		
YY	Special		

12.	Seat / retainer material		
	Seat	Retainer	Guide bushing
R1	410 SS	CB7Cu-1 / 630 SS	AISI 440C
T6	316 SS	CF8M / 316 SS	AISI 316 + Alloy 6
V6	Alloy 6	CF8M / 316 SS	AISI 316 + Alloy 6
P2	420J2	CA40/420J2	AISI 440C
R2	420J2 SS	CB7Cu-1 / 630 SS	AISI 440C
R3	316L SS	316L SS	AISI 316 + Alloy 6
YY	Special	Special	Special

- AISI 410 is general for carbon steel valve.  
- AISI 316 is general for carbon steel valve.

13.	Seat application	
X	Not applicable	
A	Cobalt based alloy	
P	Insert PTFE	
Q	Insert PTFE + Cobalt based alloy	
Y	Special	

## Others

14.	Packing / bellows type
S	General packing
E	Low emission, live loaded
C	Bellows seal (316L SS, Formed)
Y	Special

15.	Packing material
G	PTFE + Carbon fiber
F	Graphite
T	PTFE V-Ring
C	PTFE + Carbon fiber (ATEX)
H	Hi-Graphite
Y	Special

16.	Seal ring material
X	Not applicable

17.	Gasket material
S	S/W gasket type, 316L SS + Graphite
H	S/W gasket type, 316L SS + Graphite for high temp.
L	S/W gasket type, 316L SS + Hi-Graphite
Y	Special

18.	Stud / nut material
G	A193 gr. B7M / A194 gr. 2HM
D	A193 gr. B8M / A194 gr. 8M
K	A320 gr. B8M cl. 2 / A194 gr. 8M
H	A193 gr. B16 / A194 gr. 7
E	A453 gr. 660/ A453 gr. 660
Y	Special

19.	Options
X	Not applicable
E	Anti-erosion
H	Alloy 6 coating on plug & plug guide for high temperature (top-guided valve only)
L	Lub. & Isol. valve
W	Water seal
Y	Special

- \* Face to face length according to ISA 75.08
- \* The body, bonnet, trim materials are subject to change as equivalent depending on detail design.
- \* See 'Neles Globe Type code Instruction' for further options and explanations.

## Trim type &amp; rated Cv

20. Sign	Trim type	21. Sign	Trim characteristic	22. Sign	Description	Rated Cv														
						Body size and stroke														
						0.5" Str.	0.75" Str.	1" Str.	1.5" Str.	2" Str.	3" Str.	4" Str.	6" Str.							
A	General plug	E	Equal %	FC	General / Full capacity	7 (20)	9 (20)	13.5 (20)	28 (20)	49 (20)	100 (40)	190 (40)	295 (60)							
					1A	General / 1-Step reduction	4 (20)	5.5 (20)	8.5 (20)	16 (20)	28 (20)	70 (40)	120 (40)	165 (60)						
					2A	General / 2-Step reduction	2.3 (20)	3 (20)	5.4 (20)	10.5 (20)	17 (20)	42 (40)	72 (40)	85 (60)						
					3A	General / 3-Step reduction	1.5 (20)	2 (20)	3.1 (20)	6 (20)	10 (20)	25 (40)	42 (40)	50 (60)						
					4A	General / 4-Step reduction	0.8 (20)	1.2 (20)	2 (20)	4 (20)										
					5A	General / 5-Step reduction	0.5 (20)	0.7 (20)	1.2 (20)	2.2 (20)										
			L		Linear	L	Linear	FT	General / Full capacity	7 (20)	9 (20)	13.5 (20)	28 (20)	49 (20)	100 (40)	190 (40)	295 (60)			
									1T	Tendril / 1-Step reduction	4 (20)	5.5 (20)	8.5 (20)	16 (20)	28 (20)	70 (40)	120 (40)	165 (60)		
									2T	Tendril / 2-Step reduction	2.3 (20)	3 (20)	5.4 (20)	10.5 (20)	17 (20)	42 (40)	72 (40)	85 (60)		
									3T	Tendril / 3-Step reduction	1.5 (20)	2 (20)	3.1 (20)	6 (20)	10 (20)	25 (40)	42 (40)	50 (60)		
									4T	Tendril / 4-Step reduction	0.8 (20)	1.2 (20)	2 (20)	4 (20)						
									5T	Tendril / 5-Step reduction	0.5 (20)	0.7 (20)	1.2 (20)	2.2 (20)						
C	Micro plug	L	Linear	FC	General / Full capacity		0.1 (20)		0.1 (20)	0.1 (20)										
					1A		General / 1-Step reduction		0.06 (20)	0.06 (20)	0.06 (20)									
					2A		General / 2-Step reduction		0.03 (20)	0.03 (20)	0.03 (20)									
					3A		General / 3-Step reduction		0.01 (20)	0.01 (20)	0.01 (20)									
					4A		General / 4-Step reduction		0.006 (20)	0.006 (20)	0.006 (20)									
					5A		General / 5-Step reduction		0.003 (20)	0.003 (20)	0.003 (20)									
Y	Special		Y		Special	YY	Special	Contact Valmet for Cv details												

- Rated Cv is different depending on trim type and characteristic.
- Str. : valve stroke length (mm). It should be matched with actuator stroke length.

## How to order

### Angle balanced, cage guided type, series AB

1.	2.	3.	4.	5.	6.	7.	8.	9.	10.	11.	12.	13.	14.	15.	16.	17.	18.	19.	20.	21.	22.
AB	03	C	W	A	J2	B	P1	X	BC	S1	R1	X	S	F	G	S	G	X	A	E	FC

### Valve constructions

1.	Valve series	
AB	Angle balanced, cage guided type	

2.	Body size	
02	2" / DN 50	03 3" / DN 80
04	4" / DN 100	06 6" / DN 150
08	8" / DN 200	10 10" / DN 250
12	12" / DN 300	14 14" / DN 350
16	16" / DN 400	18 18" / DN 450
20	20" / DN 500	24 24" / DN 600
28	28" / DN 700	30 30" / DN 750
32	32" / DN 800	36 36" / DN 900
YY	Special	

3.	Pressure rating	
C	ASME class 150	D ASME class 300
F	ASME class 600	G ASME class 900
H	ASME class 1500	I ASME class 2500
J	EN PN 10	K EN PN 16
L	EN PN 25	M EN PN 40
N	EN PN 63	P EN PN 100
B	EN PN 160	E EN PN 250
Y	EN PN 320	

4.	End connection
W	Flanged RF, ASME B16.5
Z	Ring joint flange, ASME B16.5
V	Socket welding, ASME B16.11
Q	Butt welding, ASME B16.25
Y	Special

5.	Bonnet construction	
	Bonnet type	Actuator connection
A	General	Applicable for VD_25/29/37
B	General	Applicable for VD_48/55
C	General	Applicable for VC_30, VB_32
D	General	Applicable for VC/VB_40/50
T	General	Applicable for VC/VB_60/70
E	Extension	Applicable for VD_25/29/37
F	Extension	Applicable for VD_48/55
G	Extension	Applicable for VC_30, VB_32
H	Extension	Applicable for VC/VB_40/50
U	Extension	Applicable for VC/VB_60/70
P	Cryogenic	Applicable for VD_25/29/37
Q	Cryogenic	Applicable for VD_48/55
R	Cryogenic	Applicable for VC_30, VB_32
S	Cryogenic	Applicable for VC/VB_40/50
V	Cryogenic	Applicable for VC/VB_60/70
Y	Special	Special

6.	BODY MATERIAL
J2	A216 gr. WCB
S6	A351 gr. CF8M
J4	A217 gr. WC6
CG	A217 gr. WC9
S1	A351 gr. CF3M
YY	Special

- Bonnet material is equivalent to body material.

7.	Model code
B	Model B

### Trim constructions

8.	Plug material	
	Material	Description
P1	CA15	General for carbon steel valve
T6	CF8M	General for stainless steel valve
P2	CA40	General for high temp. Cr-Mo Valve
S1	CF3M	
YY	Special	Special materials

9.	Plug application
X	Not applicable
A	Cobalt based alloy
Y	Special

10.	Stem material	
	Material	Description
BC	630 SS + HCr	General for carbon steel valve
TC	316 SS + HCr	General for stainless steel valve
FC	316L SS + HCr	
VX	XM-19	

11.	Seat type
S1	Single metal seat
T1	Single soft seat
YY	Special

12.	Seat / cage material		
	Seat	Cage	Cage guide
R1	CA15	CB7Cu-1 + HCr	CB7Cu-1 + HCr
T6	CF8M	CF8M + HCr	CF8M + HCr
P2	CA40	CA40	CA40
R3	CF3M	CF3M + HCr	CF3M + HCr
YY	Special	Special	Special

- CA15 / AISI 410 is general for carbon steel valve.

- CF8M / AISI 316 is general for stainless steel valve.

13.	Seat application
X	Not applicable
A	Cobalt based alloy
P	Insert PTFE
Q	Insert PTFE + Cobalt based alloy
Y	Special

## Others

14.	Packing / bellows type
S	General packing
E	Low emission, live loaded
C	Bellows Seal (316L SS, Formed)
Y	Special

17.	Gasket material
S	S/W gasket type, 316L SS + Graphite
L	S/W gasket type, 316L SS + PTFE
H	S/W gasket type, 316L SS + Hi-Graphite
Y	Special

15.	Packing material
G	PTFE + Carbon fiber
F	Graphite
T	PTFE V-Ring
C	PTFE + Carbon fiber (ATEX)
H	Hi-Graphite
Y	Special

18.	Stud / nut material
G	A193 gr. B7M / A194 gr. 2HM
D	A193 gr. B8M / A194 gr. 8M
K	A320 gr. B8M cl. 2 / A194 gr. 8M
H	A193 gr. B16 / A194 gr. 7
E	A453 gr. 660 / A453 gr. 660
Y	Special

16.	Seal ring material
G	PTFE + Carbon fiber
H	PTFE + Graphite + Carbon
M	Graphite (high temp graphite seal)
N	Graphite + metal (High temp metal seal)
T	PTFE
Y	Special

19.	Options
X	Not applicable
E	Anti-erosion
L	Lub. & Isol. valve
W	Water seal
Y	Special

- \* Face to face length according to ISA 75.08
- \* The body, bonnet, trim materials are subject to change as equivalent depending on detail design.
- \* See 'Neles Globe Type code Instruction' for further options and explanations.
- \* Round bar material such as AISI 410SS (for A743 gr. CA 15), AISI 316SS (for A351 gr. CF8M), SUS420J2 (for A743 gr. CA40) and AISI 630SS (for A747 gr. CB7Cu-1) can be used depending on manufacturing process.

## Trim type & rated Cv

20. Sign	Trim type	21. Sign	Trim characteristic	22. Sign	Description	Rated Cv																	
						Body size and stroke																	
						2"	Str.	3"	Str.	4"	Str.	6"	Str.	8"	Str.	10"	Str.	12"	Str.	14"	Str.	16"	Str.
A	Balanced plug	L	Linear	FC	General / Full capacity	82	(40)	174	(50)	280	(50)	470	(60)	810	(70)	1250	(80)	1810	(120)	2530	(140)	2960	(160)
A	High temp graphite seal plug			1A	General / 1-Step reduction	74	(40)	104	(50)	170	(50)	284	(60)	500	(70)	760	(80)	1100	(120)	1540	(140)	1780	(160)
A	High temp metal seal plug			2A	General / 2-Step reduction	44	(40)	62	(50)	100	(50)	170	(60)	320	(70)	460	(80)	680	(120)	940	(140)	1080	(160)
				3A	General / 3-Step reduction	26	(40)	40	(50)	64	(50)	100	(60)	200	(70)	280	(80)	420	(120)	580	(140)	660	(160)
				FT	Tendril 1 / Full capacity	52	(40)	102	(50)	160	(50)	290	(60)	460	(70)	630	(80)	980	(120)	1300	(140)	1580	(160)
				1T	Tendril 1 / 1-Step reduction	40	(40)	75	(50)	120	(50)	220	(60)	340	(70)	460	(80)	735	(120)	985	(140)	1145	(160)
				2T	Tendril 1 / 2-Step reduction	27	(40)	40	(50)	70	(50)	130	(60)	195	(70)	255	(80)	405	(120)	565	(140)	670	(160)
				3T	Tendril 1 / 3-Step reduction	10	(40)	21	(50)	46	(50)	75	(60)	105	(70)	140	(80)	240	(120)	310	(140)	415	(160)
				FM	Tendril 2 / Full capacity	50	(40)	100	(50)	155	(50)	280	(60)	425	(70)	590	(80)	920	(120)	1240	(140)	1530	(160)
				1M	Tendril 2 / 1-Step reduction	35	(40)	74	(50)	115	(50)	215	(60)	330	(70)	450	(80)	720	(120)	970	(140)	1130	(160)
				2M	Tendril 2 / 2-Step reduction	23	(40)	33	(50)	65	(50)	120	(60)	190	(70)	240	(80)	380	(120)	550	(140)	640	(160)
				3M	Tendril 2 / 3-Step reduction	8	(40)	18	(50)	38	(50)	67	(60)	100	(70)	130	(80)	220	(120)	290	(140)	390	(160)
		E	Equal %	FC	General / Full capacity	76	(40)	160	(50)	256	(50)	430	(60)	740	(70)	1140	(80)	1650	(120)	2300	(140)	2700	(160)
				1A	General / 1-Step reduction	46	(40)	98	(50)	156	(50)	260	(60)	450	(70)	680	(80)	1000	(120)	1400	(140)	1640	(160)
				2A	General / 2-Step reduction	28	(40)	60	(50)	94	(50)	156	(60)	270	(70)	410	(80)	640	(120)	840	(140)	980	(160)
				3A	General / 3-Step reduction	18	(40)	35	(50)	60	(50)	96	(60)	164	(70)	250	(80)	384	(120)	520	(140)	600	(160)
				FT	Tendril 1 / Full capacity	50	(40)	82	(50)	135	(50)	235	(60)	370	(70)	500	(80)	840	(120)	1110	(140)	1400	(160)
				1T	Tendril 1 / 1-Step reduction	35	(40)	58	(50)	95	(50)	170	(60)	265	(70)	370	(80)	600	(120)	785	(140)	1020	(160)
				2T	Tendril 1 / 2-Step reduction	20	(40)	35	(50)	58	(50)	100	(60)	170	(70)	225	(80)	355	(120)	480	(140)	600	(160)
				3T	Tendril 1 / 3-Step reduction	10	(40)	20	(50)	32	(50)	58	(60)	105	(70)	125	(80)	205	(120)	290	(140)	350	(160)
				FM	Tendril 2 / Full capacity	47	(40)	74	(50)	130	(50)	230	(60)	330	(70)	470	(80)	770	(120)	1050	(140)	1320	(160)
				1M	Tendril 2 / 1-Step reduction	33	(40)	56	(50)	92	(50)	165	(60)	245	(70)	330	(80)	570	(120)	720	(140)	960	(160)
				2M	Tendril 2 / 2-Step reduction	19	(40)	33	(50)	52	(50)	95	(60)	145	(70)	190	(80)	330	(120)	430	(140)	550	(160)
				3M	Tendril 2 / 3-Step reduction	8	(40)	16	(50)	25	(50)	52	(60)	80	(70)	110	(80)	190	(120)	270	(140)	295	(160)
Y	Special	Y	Special	YY	Special	Contact Valmet for Cv details																	

- Rated Cv is different depending on trim characteristic.
- Str. : valve stroke length (mm). It should be matched with actuator stroke length.

## How to order

### Angle Omega trim, multi-stage type, series AM

1.	2.	3.	4.	5.	6.	7.	8.	9.	10.	11.	12.	13.	14.	15.	16.	17.	18.	19.	20.	21.	22.
AM	02	C	W	A	J2	B	P2	X	BC	S1	P2	X	S	G	G	S	G	X	A	E	O1

### Valve constructions

1.	Valve series
AM	Angle Omega trim, multi-stage type

2.	Body size		
01	1" / DN 25	1H	1.5" / DN 40
02	2" / DN 50	03	3" / DN 80
04	4" / DN 100	06	6" / DN 150
08	8" / DN 200	10	10" / DN 250
12	12" / DN 300	14	14" / DN 350
16	16" / DN 400	18	18" / DN 450
20	20" / DN 500	24	24" / DN 600
28	28" / DN 700	30	30" / DN 750
32	32" / DN 800	36	36" / DN 900
YY	Special		

3.	Pressure rating		
C	ASME class 150	D	ASME class 300
F	ASME class 600	G	ASME class 900
H	ASME class 1500	I	ASME class 2500
J	EN PN 10	K	EN PN 16
L	EN PN 25	M	EN PN 40
N	EN PN 63	P	EN PN 100
B	EN PN 100	E	EN PN 250
Y	EN PN 320		

4.	End connection
W	Flanged RF, ASME B16.5
V	Socket welding, ASME B16.11
Q	Butt welding, ASME B16.25
Z	Ring joint flange, ASME B16.5
Y	Special

5.	Bonnet construction	
	Bonnet type	Actuator connection
A	General	Applicable for VD_25/29/37
B	General	Applicable for VD_48/55
C	General	Applicable for VC_30, VB_32
D	General	Applicable for VC/VB_40/50
T	General	Applicable for VC/VB_60/70
E	Extension	Applicable for VD_25/29/37
F	Extension	Applicable for VD_48/55
G	Extension	Applicable for VC_30, VB_32
H	Extension	Applicable for VC/VB_40/50
U	Extension	Applicable for VC/VB_60/70
P	Cryogenic	Applicable for VD_25/29/37
Q	Cryogenic	Applicable for VD_48/55
R	Cryogenic	Applicable for VC_30, VB_32
S	Cryogenic	Applicable for VC/VB_40/50
V	Cryogenic	Applicable for VC/VB_60/70
Y	Special	Special

6.	Body material
J2	A216 gr. WCB
S6	A351 gr. CF8M
J4	A217 gr. WC6
CG	A217 gr. WC9
S1	A351 gr. CF3M
YY	Special

- Bonnet material is equivalent to body material.

7.	Model code
B	Model B

### Trim constructions

8.	Plug material	
	Material	Description
P2	CA40	General for carbon steel valve
T6	CF8M + HCr	General for stainless steel valve
YY	Special	Special materials

9.	Plug application
X	Not applicable
A	Cobalt based alloy
Y	Special

10.	Stem material	
	Material	Description
BC	630 SS + HCr	General for carbon steel valve
TC	316 SS + HCr	General for stainless steel valve
FC	316L SS + HCr	
VX	XM-19	

11.	Seat type
S1	Single metal seat
YY	Special

12.	Seat / disk stack material		
	Seat	Disk stack	Cage guide
P2	CA40	SUS 420J2	CA40
R4	CF8M	316L SS	CF8M + HCr
YY	Special	Special	Special

13.	Seat application
X	Not applicable
A	Cobalt based alloy
Y	Special

## Others

14.	Packing / bellows type
S	General packing
E	Low emission, Live loaded
C	Bellows Seal (316L SS, Formed)
Y	Special

15.	Packing material
G	PTFE + Carbon fiber
F	Graphite
T	PTFE V-Ring
C	PTFE + Carbon fiber (ATEX)
H	Hi-Graphite
Y	Special

16.	Seal ring material
G	PTFE + Carbon fiber
H	PTFE + Graphite + Carbon
M	Graphite (high temp graphite seal)
N	Graphite + metal (High temp metal seal)
T	PTFE
Y	Special

17.	Gasket material
S	S/W gasket type, 316L SS + Graphite
L	S/W gasket type, 316L SS + PTFE
H	S/W gasket type, 316L SS + Hi-Graphite
Y	Special

18.	Stud / nut material
G	A193 gr. B7M / A194 gr. 2HM
D	A193 gr. B8M / A194 gr. 8M
K	A320 gr. B8M cl. 2 / A194 gr. 8M
H	A193 gr. B16 / A194 gr. 7
E	A453 gr. 660 / A453 gr. 660
Y	Special

19.	Options
X	Not applicable
E	Anti-erosion
L	Lub. & Isol. valve
W	Water seal
Y	Special

\* Face to face length according to ISA 75.08

\* The body, bonnet, trim materials are subject to change as equivalent depending on detail design.

\* See 'Neles Globe Type code Instruction' for further options and explanations.

\* Round bar material such as AISI 410SS (for A743 gr. CA 15), AISI 316SS (for A351 gr. CF8M), SUS420J2 (for A743 gr. CA40) and AISI 630SS (for A747 gr. CB7Cu-1) can be used depending on manufacturing process.

## Trim type & rated Cv

20. Sign	Trim type	21. Sign	Trim characteristic	22. Sign	Description	Rated Cv										
						Body size and stroke										
						1" Str.	1.5" Str.	2" Str.	3" Str.	4" Str.	6" Str.	8" Str.	10" Str.	12" Str.	14" Str.	16" Str.
A	Balanced plug	L	Linear	C1	FC / 6 turns / FTC	8.2 (20)	13.7 (20)	41 (40)	70 (50)	110 (50)	160 (60)	270 (70)	370 (80)	580 (120)	800 (140)	1000 (160)
A	High temp. balanced plug			C2	FC / 10 turns / FTC	6.7 (20)	11 (20)	33 (40)	60 (50)	90 (50)	130 (60)	210 (70)	290 (80)	480 (120)	660 (140)	820 (160)
P	Pilot balanced plug			C3	FC / 14 turns / FTC	4.2 (20)	7.8 (20)	27 (40)	48 (50)	60 (50)	110 (60)	140 (70)	200 (80)	340 (120)	470 (140)	650 (160)
U	Unbalanced plug			C4	FC / 18 turns / FTC			21 (40)	29 (50)	48 (50)	80 (60)	110 (70)	160 (80)	280 (120)	390 (140)	530 (160)
				C5	FC / 22 turns / FTC			15 (40)	24 (50)	39 (50)	60 (60)	90 (70)	110 (80)	200 (120)	320 (140)	370 (160)
				CA	1A / 6 turns / FTC	6.2 (20)	6.3 (20)	24 (40)	41 (50)	60 (50)	90 (60)	150 (70)	210 (80)	310 (120)	500 (140)	660 (160)
				CB	1A / 10 turns / FTC	2.9 (20)	5.2 (20)	20 (40)	34 (50)	50 (50)	70 (60)	120 (70)	170 (80)	250 (120)	410 (140)	540 (160)
				CC	1A / 14 turns / FTC	2.4 (20)	5.2 (20)	16 (40)	28 (50)	41 (50)	60 (60)	90 (70)	130 (80)	210 (120)	340 (140)	450 (160)
				CD	1A / 18 turns / FTC			13 (40)	19 (50)	30 (50)	45 (60)	70 (70)	100 (80)	170 (120)	280 (140)	310 (160)
				CE	1A / 22 turns / FTC			8.7 (40)	16 (50)	25 (50)	37 (60)	49 (70)	80 (80)	130 (120)	190 (140)	260 (160)
				O1	FC / 6 turns / FTO	7.2 (20)	12.5 (20)	36 (40)	70 (50)	100 (50)	160 (60)	270 (70)	350 (80)	540 (120)	790 (140)	960 (160)
				O2	FC / 10 turns / FTO	6.9 (20)	10 (20)	29 (40)	55 (50)	90 (50)	140 (60)	220 (70)	300 (80)	470 (120)	650 (140)	790 (160)
				O3	FC / 14 turns / FTO	4.9 (20)	7.2 (20)	24 (40)	45 (50)	60 (50)	110 (60)	150 (70)	200 (80)	350 (120)	480 (140)	620 (160)
				O4	FC / 18 turns / FTO			19 (40)	30 (50)	49 (50)	80 (60)	120 (70)	170 (80)	290 (120)	390 (140)	510 (160)
				O5	FC / 22 turns / FTO			15 (40)	25 (50)	41 (50)	70 (60)	100 (70)	110 (80)	200 (120)	320 (140)	380 (160)
				OA	1A / 6 turns / FTO	5.6 (20)	5.7 (20)	23 (40)	40 (50)	60 (50)	90 (60)	150 (70)	210 (80)	300 (120)	470 (140)	620 (160)
				OB	1A / 10 turns / FTO	2.6 (20)	4.7 (20)	19 (40)	33 (50)	49 (50)	70 (60)	120 (70)	170 (80)	240 (120)	390 (140)	510 (160)
				OC	1A / 14 turns / FTO	2.2 (20)	3.9 (20)	16 (40)	27 (50)	41 (50)	60 (60)	90 (70)	130 (80)	200 (120)	320 (140)	420 (160)
				OD	1A / 18 turns / FTO			13 (40)	19 (50)	30 (50)	46 (60)	70 (70)	100 (80)	170 (120)	260 (140)	290 (160)
				OE	1A / 22 turns / FTO			8.4 (40)	16 (50)	25 (50)	38 (60)	50 (70)	80 (80)	120 (120)	180 (140)	240 (160)
		E	Equal%	C1	FC / 6 turns / FTC	6.6 (20)	10 (20)	34 (40)	60 (50)	90 (50)	130 (60)	210 (70)	300 (80)	500 (120)	690 (140)	860 (160)
				C2	FC / 10 turns / FTC	5.5 (20)	8.3 (20)	28 (40)	46 (50)	70 (50)	110 (60)	160 (70)	230 (80)	410 (120)	570 (140)	710 (160)
				C3	FC / 14 turns / FTC	3.5 (20)	6 (20)	23 (40)	38 (50)	48 (50)	90 (60)	110 (70)	170 (80)	300 (120)	390 (140)	570 (160)
				C4	FC / 18 turns / FTC			16 (40)	22 (50)	39 (50)	60 (60)	90 (70)	140 (80)	250 (120)	320 (140)	470 (160)
				C5	FC / 22 turns / FTC			12 (40)	18 (50)	32 (50)	50 (60)	80 (70)	90 (80)	160 (120)	260 (140)	310 (160)
				CA	1A / 6 turns / FTC	4.5 (20)	6.5 (20)	22 (40)	40 (50)	70 (50)	80 (60)	120 (70)	210 (80)	320 (120)	470 (140)	540 (160)
				CB	1A / 10 turns / FTC	3.7 (20)	5.3 (20)	18 (40)	33 (50)	50 (50)	60 (60)	100 (70)	170 (80)	260 (120)	380 (140)	450 (160)
				CC	1A / 14 turns / FTC	2.6 (20)	4.4 (20)	15 (40)	27 (50)	31 (50)	50 (60)	80 (70)	140 (80)	220 (120)	310 (140)	370 (160)
				CD	1A / 18 turns / FTC			12 (40)	17 (50)	25 (50)	43 (60)	70 (70)	90 (80)	180 (120)	260 (140)	300 (160)
				CE	1A / 22 turns / FTC			7.8 (40)	14 (50)	21 (50)	36 (60)	60 (70)	70 (80)	120 (120)	170 (140)	250 (160)
				O1	FC / 6 turns / FTO	6 (20)	9.2 (20)	32 (40)	60 (50)	90 (50)	140 (60)	210 (70)	290 (80)	470 (120)	690 (140)	850 (160)
				O2	FC / 10 turns / FTO	5.5 (20)	7.6 (20)	26 (40)	46 (50)	70 (50)	110 (60)	180 (70)	250 (80)	410 (120)	570 (140)	700 (160)
				O3	FC / 14 turns / FTO	4 (20)	5.5 (20)	21 (40)	38 (50)	49 (50)	90 (60)	120 (70)	170 (80)	310 (120)	390 (140)	550 (160)
				O4	FC / 18 turns / FTO			16 (40)	23 (50)	41 (50)	70 (60)	100 (70)	140 (80)	250 (120)	320 (140)	450 (160)
				O5	FC / 22 turns / FTO			12 (40)	19 (50)	33 (50)	50 (60)	80 (70)	100 (80)	170 (120)	270 (140)	320 (160)
				OA	1A / 6 turns / FTO	4.1 (20)	5.9 (20)	21 (40)	39 (50)	70 (50)	80 (60)	120 (70)	210 (80)	310 (120)	440 (140)	510 (160)
				OB	1A / 10 turns / FTO	3.4 (20)	4.8 (20)	18 (40)	32 (50)	50 (50)	70 (60)	100 (70)	170 (80)	250 (120)	360 (140)	420 (160)
				OC	1A / 14 turns / FTO	2.8 (20)	4 (20)	14 (40)	26 (50)	31 (50)	50 (60)	80 (70)	140 (80)	210 (120)	300 (140)	340 (160)
				OD	1A / 18 turns / FTO			12 (40)	17 (50)	26 (50)	44 (60)	70 (70)	90 (80)	170 (120)	240 (140)	280 (160)
				OE	1A / 22 turns / FTO			7.6 (40)	14 (50)	21 (50)	36 (60)	60 (70)	70 (80)	110 (120)	160 (140)	230 (160)
Y	Special	Y	Special	YY	Special	Please contact Valmet for more information										

- Rated Cv is different depending on trim type and characteristic.
- Str. : valve stroke length (mm). It should be matched with actuator stroke length.
- FC / FTC / FTO= Full capacity // Flow to close or Flow to open
- 1A / FTC or FTO = 1-Step reduction // Flow to open or Flow to close

Subject to change without prior notice.

Neles, Neles Easyflow, Jamesbury, Stonel, Valvcon and Flowrox, and certain other trademarks, are either registered trademarks or trademarks of Valmet Oyj or its subsidiaries in the United States and/or in other countries.

### Valmet Flow Control Oy

Vanha Porvoontie 229, 01380 Vantaa, Finland.

Tel. +358 10 417 5000.

[www.valmet.com/flowcontrol](http://www.valmet.com/flowcontrol)

