

Trunnion mounted full bore Neles™ ball valve Series XG, XM

Installation, maintenance and
operating instructions

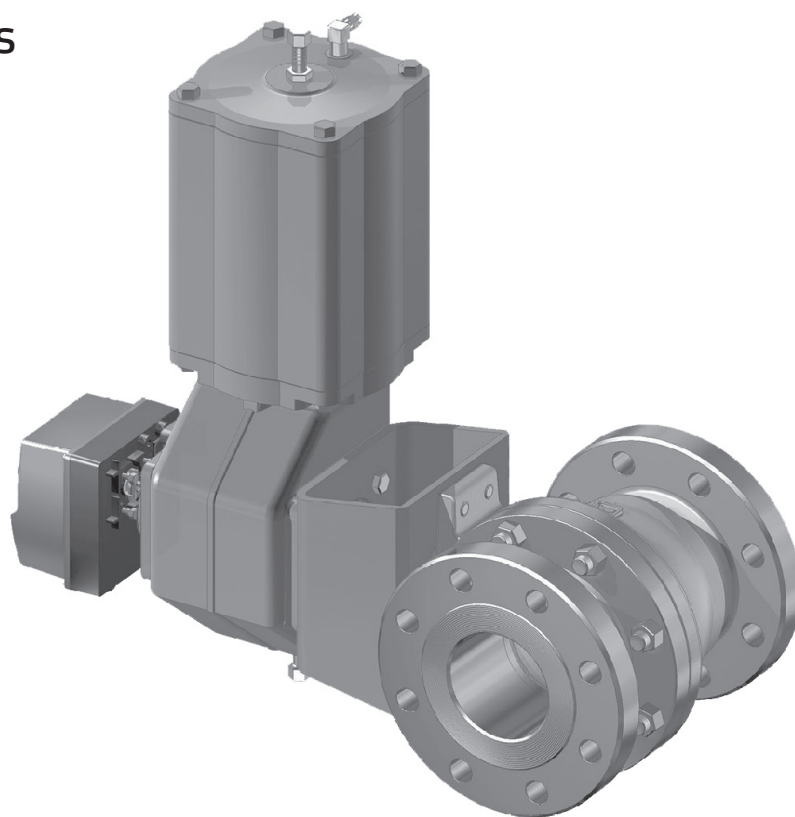

Table of contents

GENERAL	3	TESTING THE VALVE	11
Scope of the manual	3	INSTALLING THE ACTUATOR	11
Valve description	3	General	11
Markings	3	Installing the M-handwheel operator	11
Technical specification	4	Installing the B1C-series actuator	11
CE and ATEX marking	4	Installing the B1J-series actuator	12
Recycling and disposal	4	Installing other makes of actuators	12
Safety precautions	4		
Welding notes	5		
TRANSPORTATION, RECEPTION AND STORAGE	5	TROUBLE SHOOTING TABLE	12
INSTALLATION AND USE	5	TOOLS	12
General	5	ORDERING SPARE PARTS	12
Installing in the pipeline	5	EXPLODED VIEW AND PARTS LIST	13
Actuator	6	DIMENSIONS	15
Commissioning	6	TYPE CODE	18
MAINTENANCE	7	GENERAL SAFETY WARNINGS AND DISCLAIMERS	20
Maintenance general	7	General safety warnings	20
Changing the gland packing while the valve is in the pipeline	7	General disclaimers	20
Repair of a jammed or stuck valve while it is in the pipeline	8		
Detaching the actuator	8		
Removing the valve from the pipeline	8		
Dismantling the valve	8		
Inspection of removed parts	9		
Replacing parts	9		
Re-assembly of the valve	9		

Subject to change without notice.

All trademarks are property of their respective owners.



This product meets the requirements set by the Customs Union of the Republic of Belarus, the Republic of Kazakhstan and the Russian Federation.

READ THESE INSTRUCTIONS FIRST!

These instructions provide information about safe handling and operation of the valve.

If you require additional assistance, please contact the manufacturer or manufacturer's representative.

SAVE THESE INSTRUCTIONS!

Addresses and phone numbers are printed on the back cover.

1. GENERAL

1.1 Scope of the manual

This installation, operation and maintenance manual provides essential information on trunnion mounted XG/XM series ball valves. The actuators and instrumentation to be used with these valves are also discussed briefly. Refer to the separate actuator and control equipment instruction manuals for further information.

NOTE:

Selection and use of the valve in a specific application requires close consideration of detailed aspects. E.g. Q2G-trim is for relatively clean gas applications, note possibility of clogging. Due to the nature of the product, this manual cannot cover all the individual situations that may occur when installing, using or servicing the valve.

If you are uncertain about use of the valve or its suitability for your intended purpose, please contact Valmet for more information.

For valves in oxygen service, please see also the separate installation, maintenance and operating instructions for oxygen service (see Neles document id:10O270EN.pdf)

1.2 Valve description

Trunnion mounted XG/XM series valves are flanged full bore ball valves. The valve body is in two parts, fastened together by body-joint bolting. The ball and shaft are separate. Shaft blow-out is prevented by bonnet and a shoulder machined on the shaft.

The valve is either soft or metal seated. Shaft torque is transmitted to the ball through a splined connection (sizes DN50/NPS2 - 400/16) or square connection (sizes DN450/NPS18 - 600/24).

The valve is 1-way or 2-way tight depending on the seat construction. Tightness direction is shown with an arrow on 1-way valves.

Construction details of individual valves are included in the type code shown on the valve identification plate. To interpret the type code, please refer to the type coding key in this manual.

Trunnion mounted XG/XM series ball valves are specially designed for demanding throttling and shut-off service with high pressure differentials.

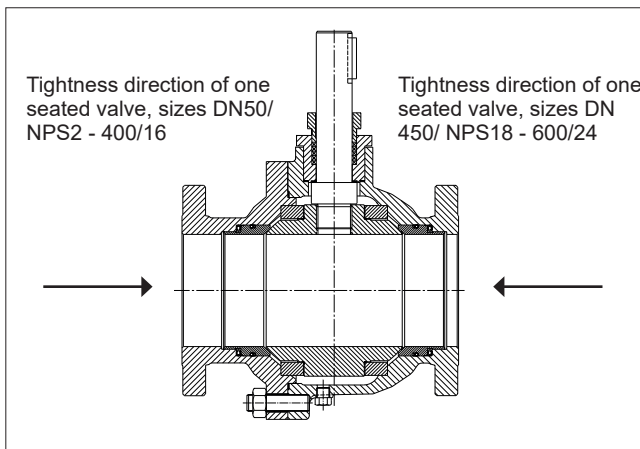

Fig. 1 Construction of a trunnion mounted XG/XM series ball valve

1.3 Markings

Body markings are cast or stamped on the body (see Fig. 2).

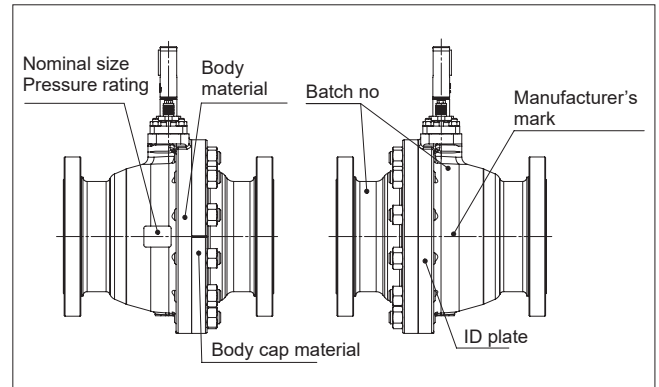

Fig. 2 Valve markings

The identification plate (Fig. 3) is attached to the flange. Identification plate markings are:

1. Body material
2. Shaft material
3. Trim material
4. Seat material
5. Max and min operating temperature
6. Max shut-off pressure at room temperature
7. Pressure class
8. Type designation
9. Valve manufacturing parts list no.
10. Model
11. Certification and approvals, eg. CE, Atex etc.

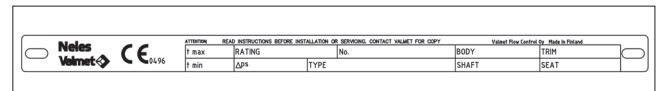

Fig. 3 Example of identification plate

1.4 Technical specification

Product type

Full bore trunnion mounted ball valve.

Split body design.

Flanged.

Pressure ratings

ASME Class 150 and 300.

Size range

2" ... 24" in ASME Class 150 & 300.

Temperature range

-50 ... +400 °C (-60 ... +750 °F), consult factory for higher temperature applications.

Design standard

Valve body ASME B16.34

Valve flanges ASME B16.5

Face-to-face ASME B16.10 long pattern.

Actuator mounting ISO 5211.

Standard materials

Body	ASTM A216 gr WCB ASTM A351 gr. CF8M.
Ball	ASTM A351 gr. CF8M/AISI 316 + hard chrome plating with metal seats.
Bearings	PTFE or cobalt based alloy.
Seats	AISI 316 + cobalt based alloy. AISI 316 + PTFE insert.
Seals/gaskets	PTFE, graphite.
Body gaskets	Spiral wound with PTFE or graphite filler.
Gland packing	PTFE (V-ring) or graphite with live loaded construction.
Bolting	B8M/8M with stainless steel body. L7M/2HM with carbon steel body.

NOTE:

Final valve materials may vary due to application and customer requirements. The final selected materials are shown in the bill of materials of delivered valve.

Standard options

High temperature linkages.

Oxygen construction for gaseous oxygen service.

High temperature design.

Carbide or NiBo ball coating.

Q-TRIM design (2" ... 24")

Q2-TRIM design (2" ... 16")

NACE MR-01-03 as standard, NACE MR-01-75 on request.

Material and test certification

EN 10204-3.1 material certificates for body and bonnet.

Tightness test certificate.

Fire tested

API 607, with D, B, K, G and H seats.

Valve testing

Each valve is tested for body integrity and seat tightness.

The body test pressure is 1.5 x PN. The seat test pressure is 1.1 x PN. Test medium is inhibited water.

Air test upon request.

Valve tightness

ISO 5208 Rate C or Class V for metal seats.

ISO 5208 Rate B or Class VI for soft seats.

Other tightness rates upon request.

1.5 CE and ATEX marking

The valve meets the requirements of the European Directive 2014/68/EU relating to pressure equipment, and has been marked according to the Directive.

When applicable, the valve meets the requirements of the European Directive 2014/34/EU relating to equipment and protective systems intended for use in potentially explosive atmospheres, and has been marked according to the Directive.

1.6 Recycling and disposal

Most valve parts can be recycled if sorted according to material.

Most parts have material marking. A material list is supplied with the valve.

In addition, separate recycling and disposal instructions are available from the manufacturer.

A valve can also be returned to the manufacturer for recycling and disposal against a fee.

1.7 Safety precautions

CAUTION:

Do not exceed the valve performance limitations!

Exceeding the limitations marked on the valve may cause damage and lead to uncontrolled pressure release. Damage or personal injury may result.

CAUTION:

Do not dismantle the valve or remove it from the pipeline while the valve is pressurized!

Dismantling or removing a pressurized valve will result in uncontrolled pressure release. Always isolate the relevant part of the pipeline, release the pressure from the valve and remove the medium before dismantling the valve. Be aware of the type of medium involved. Protect people and the environment from any harmful or poisonous substances. Make sure that no medium can enter the pipeline during valve maintenance. Failure to do this may result in damage or personal injury.

CAUTION:

Beware of the ball cutting movement!

Keep hands, other parts of the body, tools and other objects out of the open flow port. Leave no foreign objects inside the pipeline. When the valve is actuated, the ball functions as a cutting device. Close and detach the actuator pressure supply pipeline for valve maintenance. Failure to do this may result in damage or personal injury.

CAUTION:

Beware of noise emission!

The valve may produce noise in the pipeline. The noise level depends on the application. It can be measured or calculated using the Neles Nelprof computer program.

Observe the relevant work environment regulations on noise emission.

CAUTION:**Beware of extreme temperatures!**

The valve body may be very hot or very cold during use. Protect people against cold injuries or burns.

CAUTION:**When handling the valve or the valve package, bear in mind its weight!**

Never lift the valve or valve package by the actuator, positioner, limit switch or their piping. Place the lifting ropes securely around the valve body. Please consult separate document: Instructions for lifting Neles products. (See Neles document id: 10LIFT70en.pdf). Damage or personal injury may result from falling parts.

The weights are shown on pages 16-17.

CAUTION:

Follow the proper procedures when handling and servicing oxygen valves.

ATEX/Ex Safety

CAUTION!

Potential electrostatic hazard, ensure the protection (grounding, etc.) in the process.

CAUTION!

The actual surface temperature of valve is depended on the process temperature. The protection from high or low temperature must be considered by the end user before valve is put into service.

CAUTION!

Ensure the general process and worker protection from static electricity in the facilities.

Note! Within series there is possibility to Category 2, Category 3 and non-ATEX valve.

1.8 Welding notes

WARNING:

Welding and/or grinding stainless steel and other alloys containing chromium metal may cause the release of hexavalent chromium. Hexavalent chromium(VI) or Cr(VI), is known to cause cancer. Be sure to use all appropriate personal protective equipment (PPE) when welding metals containing chromium.

NOTE:

A qualified welder must do the installation welding. The welder and welding procedure should be qualified in accordance with the ASME Boiler and Pressure Vessel Code Section IX or other applicable regulation.

CAUTION:

To prevent damage to the seat and seals, do not allow the temperature of the seat and body seal area to exceed 94 °C (200 °F). It is recommended that thermal chocks be used to check the temperature in these areas during welding.

CAUTION:

Ensure that any weld splatter does not fall onto the valve closing members eg. ball or seats. This may damage critical seating surfaces and cause leaks.

2. TRANSPORTATION, RECEPTION AND STORAGE

Check the valve and the accompanying device for any damage that may have occurred during transport.

Store the valve carefully. We recommend storing indoors in a dry place.

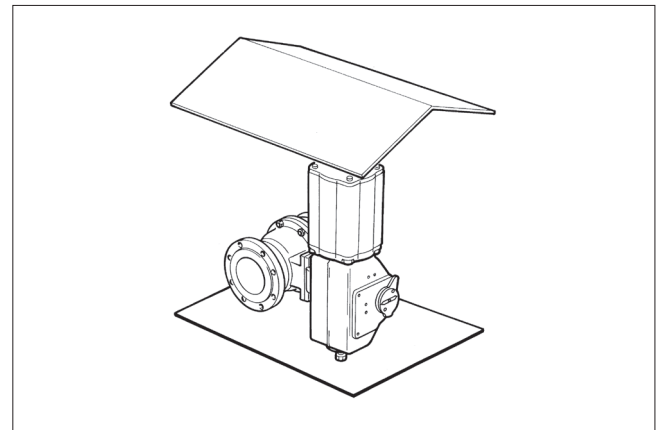

Fig. 4 Storing the valve

Do not remove the flow port protectors until installing the valve.

Move the valve to its intended location just before installation.

The valve is usually delivered in the open position.

3. INSTALLATION AND USE

3.1 General

Remove the flow bore protectors and check that the valve is clean inside. Clean the valve if necessary.

Please consult separate document: Instructions for lifting Neles products. (See Neles document id: 10LIFT70en.pdf)

3.2 Installing in the pipeline

CAUTION:

When handling the valve or the valve package as a whole, bear in mind the weight of the valve or the entire package!

Flush the pipeline carefully before installing the valve. Make sure the valve is entirely open when flushing. Foreign particles, such as sand or pieces of welding electrode, will damage the ball and seats.

NOTE:

Use screws, nuts, bolts and gaskets equivalent to the fastenings used elsewhere in the pipeline. Center the flange gaskets carefully when fitting the valve between flanges.

NOTE:

Do not attempt to correct pipeline misalignment by means of flange bolting.

The valve may be installed in any position and offers 1-way or 2-way tightness, see Sections 1.2 and 1.4. However we do not recommend installing the valve with the actuator on the underneath side because dirt in the pipeline may then enter the body cavity and damage the gland packing. The position to be avoided is shown in Fig. 5.

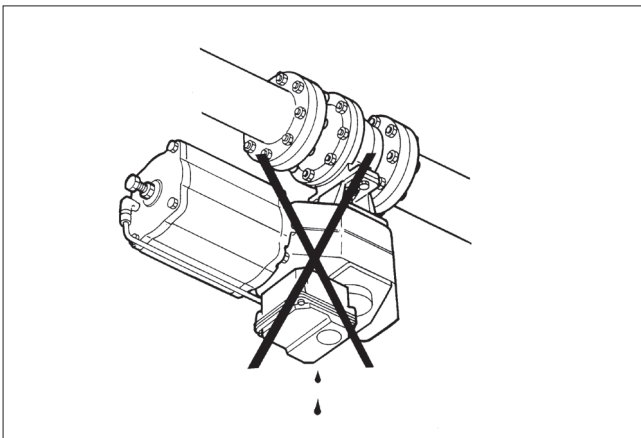

Fig. 5 Avoid this mounting position

It may be necessary to firmly support the pipeline in order to protect the valve from excess stress. Sufficient support will also reduce pipeline vibration and thus ensures proper functioning of the positioner.

To facilitate servicing, it is preferable that the valve be supported by the body, using pipe clamps and supports. Do not fasten supports to the flange bolting or to the actuator, see Fig. 6.

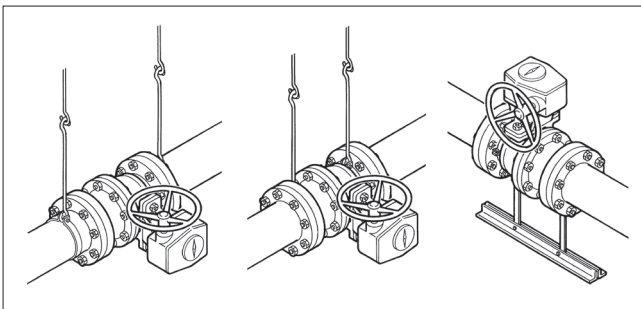

Fig. 6 Supporting the valve

Valve insulation

If necessary, the valve may be insulated. Insulation must not continue above the upper level of the valve body, see Figure 7.

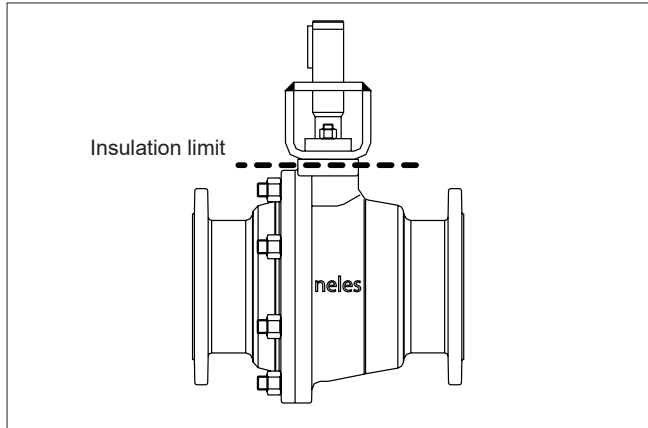

Fig. 7 Insulation of the valve

3.3 Actuator

NOTE:

When installing the actuator on the valve, make sure that the valve package functions properly. Detailed information on actuator installation is given in Section 6 or in the separate actuator instructions.

The valve open/closed position is indicated as follows:

- by an indicator on the actuator
or
- by a groove at the end of the ball shaft (parallel to the ball flow opening).

If there is any uncertainty about the indicator, check the ball position by the groove.

The actuator should be installed in a manner that allows plenty of room for its removal.

The upright position is recommended for the actuator cylinder.

The actuator must not touch the pipeline, because pipeline vibration may interfere with its operation.

In certain cases it may be considered advantageous to provide additional support to the actuator. These cases will normally be associated with large actuators, extended shafts, or where severe vibration is present. Please contact Valmet for advice.

3.4 Commissioning

Ensure that there is no dirt or foreign objects left inside the valve or pipeline. Flush the pipeline carefully. Make sure that the valve is entirely open when flushing.

Ensure that all nuts, pipings, and cables are properly fastened.

Check that the actuator, positioner, and switch are correctly adjusted. Actuator adjustment is explained in Section 6. To adjust the accompanying device refer to the separate control equipment instruction manuals.

4. MAINTENANCE

CAUTION:

Observe the safety precautions mentioned in Section 1.7 before maintenance!

CAUTION:

When handling the valve or the valve package as a whole, bear in mind the weight of the valve or the entire package!

4.1 Maintenance general

Although Neles valves are designed to work under severe conditions, proper preventative maintenance can significantly help to prevent unplanned downtime and in real terms reduce the total cost of ownership. Valmet recommends inspecting the valves at least every five (5) years. The inspection and maintenance interval depends on the actual application and process condition. The inspection and maintenance intervals can be specified together with your local Valmet experts. During this periodic inspection the parts detailed in the Spare Part Set should be replaced. Time in storage should be included in the inspection interval.

Maintenance can be performed as presented below. For maintenance assistance, please contact your local Valmet office. The part numbers in the text refer to the exploded view and to the parts list in Section 10, unless otherwise stated.

NOTE:

When sending goods to the manufacturer for repair, do not disassemble them. Clean the valve carefully and flush the valve internals. For safety reasons, inform the manufacturer of the type of medium used in the valve (include material safety datasheets (MSDS)).

NOTE:

In order to ensure safe and effective operation, always use original spare parts to make sure that the valve functions as intended.

NOTE:

For safety reasons, replace pressure retaining bolting if the threads are damaged, have been heated, stretched or corroded.

4.2 Changing the gland packing while the valve is in the pipeline

CAUTION:

Do not dismantle the valve or remove it from the pipeline while the valve is pressurized!

The V-ring gland packing requires no regular tightening. The gland packing tightness is provided by the pipeline pressure together with gland pressure against the packing rings. In graphite gland packings, tightness is ensured by contact between the gland follower and the packing rings.

The gland packing (69) must be changed if leakage occurs even after the hex nuts (18) have been tightened. The V-ring gland packing must be tightened with care because excess force may damage the V-rings.

- Make sure that the valve is not pressurized.
- Detach the actuator and bracket according to the instructions in Section 4.4.
- Remove the key (10).
- Remove the nuts (18), the disc spring sets (150) and the gland (9).
- Remove old packing rings (69). Do not damage the surfaces of the packing ring counterbore and shaft.
- Clean the packing ring counterbore.
- Place the new packing rings (69) over the shaft (5). The gland follower may be used for pushing the rings into the counterbore. Do not damage packing rings in the shaft keyway. See Fig. 8 for proper orientation.
- Pre-compress the packing rings first by tightening the gland nuts without disc spring sets to the torque T_t , see value from table 1.
- Sizes 18"/DN450 ... 24"/DN600: Remove the gland nuts. Install washers (150a) and torsion springs (150b) on the gland studs (14). Continue to next bullet, the disc spring set comes on top of the washer and torsion spring.
- Remove the gland nuts and place the disc spring sets on the gland studs. Tighten the nuts so that the disc spring sets are compressed to the height H_2 , see tables 1 and 2. Lock the nuts with locking compound e.g. Loctite 221.
- Check leakage when the valve is pressurized.

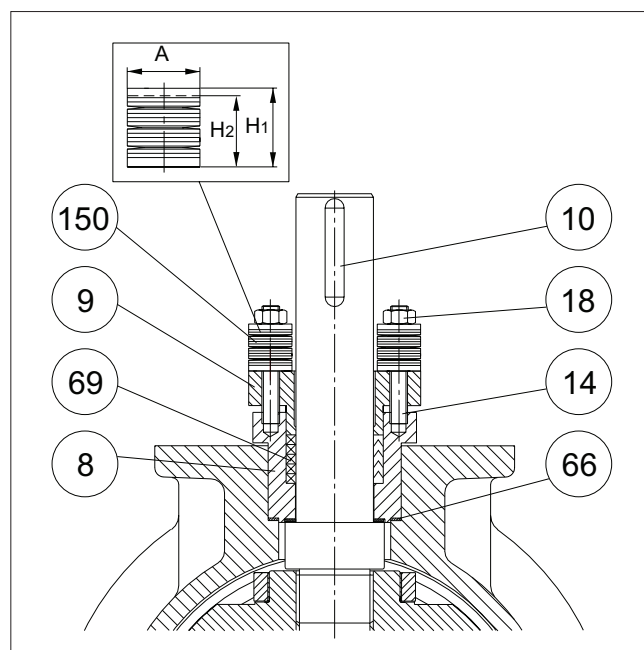

Fig. 8 Gland packing

Table 1 Tightening of the gland packing with stainless steel disc spring sets (*)

Valve size		Shaft dia (mm)	Spring dimensions			PTFE V-ring		Graphite		Graphite (Braided)		ID code of disc spring set
DN	NPS		A (mm)	H1 (mm)	H2 (mm)	Tt (Nm)	H2 (mm)	Tt (Nm)	H2 (mm)	Tt (Nm)		
50	02"	20	20	24	23.1	4	22.3	7	-	-	H148583	
80	03"	20	20	24	23.1	4	22.3	7	-	-	H148583	
100	04"	25	25	33.4	31.9	11	31.3	22	-	-	H148584	
150	06"	40	25	33.4	31.9	11	31.3	21	-	-	H148584	
200	08"	40	25	33.4	31.9	11	31.3	21	-	-	H148584	
250	10"	55	35.5	43.5	41.8	25	40.5	51	-	-	H148585	
300	12"	55	35.5	43.5	41.8	25	40.5	51	-	-	H148585	
350	14"	75	50	59	56.7	47	54.3	94	-	-	H148587	
400	16"	85	50	59	56.4	53	54.0	106	-	-	H148587	
450	18"	85	50	59	56.4	53	54.0	106	54.0	159	H148587	
500	20"	85	50	59	56.4	53	54.0	106	54.0	159	H148587	
500	20"	95	71	73	69.5	125	66.1	250	66.0	375	H148589	
600	24"	95	71	73	69.5	125	66.1	250	66.0	375	H148589	
600	24"	120	71	73	68.7	154	66.0	309	66.0	464	H148589	

(*) Disc spring set material change has been done in mid 2019. Sizes 18" / DN 450 ... 24" / DN600 have been available only with stainless steel disc springs.

Table 2 Tightening of the gland packing with carbon steel+ENP coated disc spring sets

Valve size		Shaft dia (mm)	Spring dimensions			PTFE V-ring		Graphite		ID code of disc spring set
DN	NPS		A (mm)	H1 (mm)	H2 (mm)	Tt (Nm)	H2 (mm)	Tt (Nm)		
50	02"	20	20	22	21.0	4	20.2	7	979540	
80	03"	20	20	22	21.0	4	20.2	7	979540	
100	04"	25	25	30.5	29.3	11	28.4	22	979560	
150	06"	40	25	30.5	28.9	11	28.2	21	979560	
200	08"	40	25	30.5	28.9	11	28.2	21	979560	
250	10"	55	35.5	41	38.8	25	37.4	51	979580	
300	12"	55	35.5	41	38.8	25	37.4	51	979580	
350	14"	65	50	59	57.3	41	55.3	83	979620	
400	16"	75	50	59	57.1	47	54.9	94	979620	

4.3 Repair of a jammed or stuck valve while it is in the pipeline

Jamming may be due to the ball (3) and seats (7) becoming clogged with flow medium. They may be cleaned by turning the ball to the partly open position and flushing the pipeline. If this does not help, follow the instructions in the following sections.

4.4 Detaching the actuator

CAUTION:

When handling the valve or the valve package as a whole, bear in mind the weight of the valve or the entire package!

CAUTION:

Do not detach a spring-return actuator unless a stop-screw is carrying the spring force!

NOTE:

Before dismantling, carefully observe the position of the valve with respect to the actuator and positioner/limit switch so as to make sure that the package can be properly re-assembled.

It is generally most convenient to detach the actuator before removing the valve from the pipeline. If the valve is small or if it is difficult to access, it may be more practical to remove the entire package at the same time.

- Close and detach the actuator pressure supply pipeline and remove control cables.
- Unscrew the bracket screws.
- Detach the actuator. The actuator can be removed by hand or with a special tool made for this purpose. The tool can be ordered from the manufacturer (see Section 8 "Tools").
- Remove the bracket.

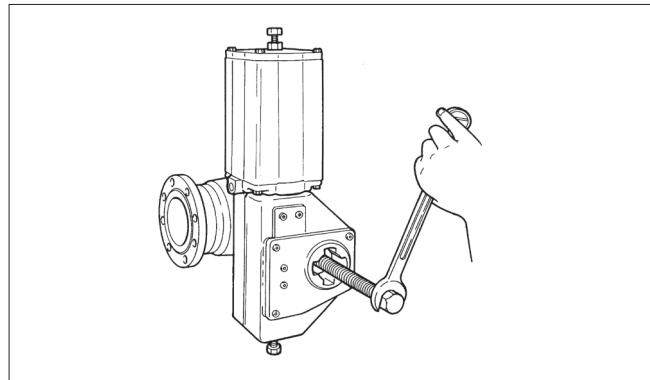

Fig. 9 Removing the actuator with an extractor

4.5 Removing the valve from the pipeline

CAUTION:

Do not dismantle the valve or remove it from pipeline while the valve is pressurized!

- Make sure that the valve is not pressurized and that the pipeline is empty. Make sure that the medium cannot flow into the section where servicing is to take place.
- Support the valve carefully with a hoist. Place ropes carefully and unscrew the pipe flange bolts. Place the lifting sling around body, avoid any contact with the instrumentation. Lift valve down. Please consult separate document: Instructions for lifting Neles products. (See Neles document id: 10LIFT70en.pdf)

4.6 Dismantling the valve

- Place the valve in a standing position on the pipe flange end. Use a level surface that will not scratch the flanges. See that the body stud nuts (16) are facing upward.
- Mark the the body halves for correct orientation during re-assembly.
- Turn the ball to the closed position.
- Remove the key (10).
- Unscrew the gland nuts (18). Remove the disc spring sets (150) and the gland (9).
- Unscrew the body stud nuts (16).
- Remove the body cap (2). If the seat (7) is not lying on the ball (3), prevent the seat from falling from the body cap and detach it later. **Don't leave your fingers between the body cap and the surface!**
- Stand the removed body cap on its pipe flange.
- Remove the seat (7) from body cap (2) if it is still in place.

- Unscrew the bonnet stud nuts (17). Remove the shaft (5) and bonnet (8). Knock the bonnet off with a piece of wood and a hammer, if needed.
- Lift the ball (3) along with the trunnion plates (89) out of the body (1). Handle the ball carefully and place it on a soft surface.
- Remove the seat (7) from the body (1).
- Remove the trunnion plates (89) from the hubs of the ball.
- Remove the trunnion bearings (99) and the thrust bearings (91) from each trunnion.
- Push the shaft out of the bonnet.
- Remove thrust bearings (70, 71) from the shaft and packing rings (69) from the bonnet (8).
- Remove the body gasket (65) and the bonnet gasket (66).

4.7 Inspection of removed parts

- Clean removed parts.
- See if the shaft (5) or bearings (70, 71, 91, 99) are damaged.
- See if the ball (3) or seats (7) are damaged (scratched), by examining them under bright light. The ball and the seat can be replaced if necessary.
- See if the body joint sealing surfaces are damaged.

4.8 Replacing parts

We recommend that soft material parts be replaced whenever the valve is dismantled for servicing. Other parts may be replaced if necessary. Always use genuine spare parts to ensure proper functioning of the valve (see section "Ordering spare parts").

4.9 Re-assembly of the valve

- Place the valve body (1) and the body cap (2) on the pipe flange end. Use a level surface that will not scratch the flanges.

Pre assembly of the seats

S and T seats:

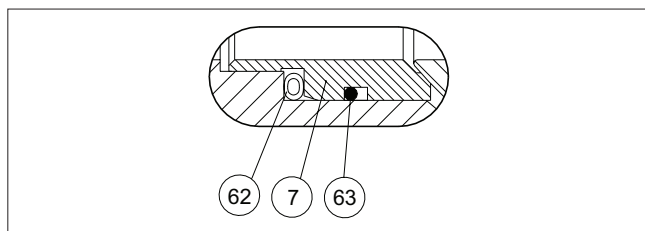

Fig. 10 S seat

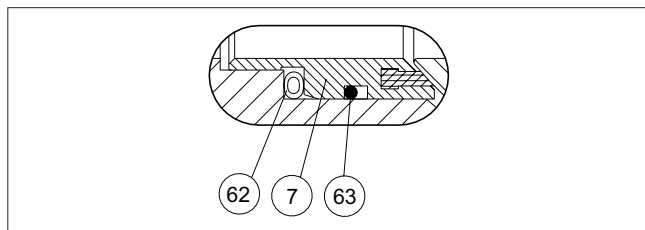

Fig. 11 T seat

- Check the sealing surfaces.
- Place the O-ring (63) into the groove in the seat. See Figures 10 and 11.

- For easier assembly, lubricate the O-ring surfaces facing the seats with silicone grease or another suitable substance. Please ensure the compatibility with the flow medium.
- Place the spring (62) into the groove in the seat (7). Connect the ends of the spring.
- Place the seats into the body and body cap by hand or if necessary, using a plastic mallet. The seat is in correct position when the spring touches the body shoulder.

D and B seats:

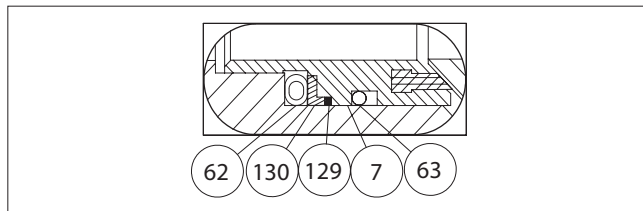

Fig. 12 D seat

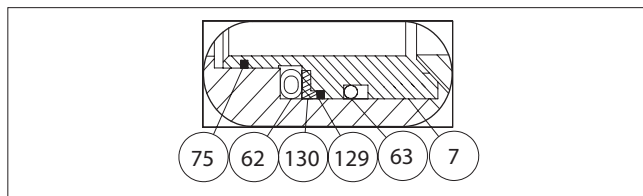

Fig. 13 B seat

K and G seats:

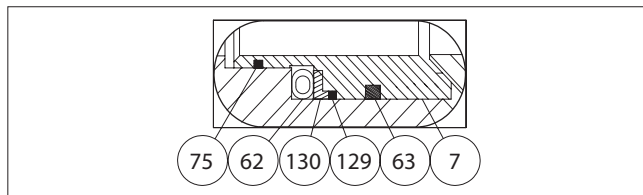

Fig. 14 G and K seat

H seats:

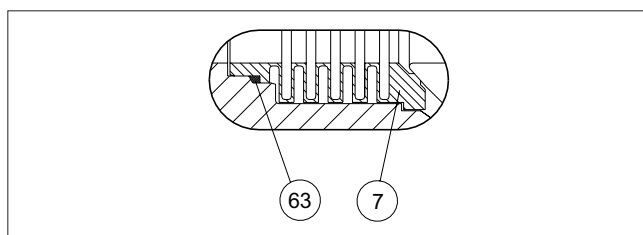

Fig. 15 H seat

- Check the sealing surfaces.
- Place the back seal (63) into the seat (7). See Figure 15.
- Place the seat into the body counterbore.

L seats:

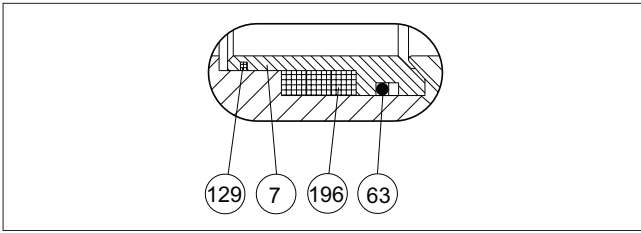

Fig. 16 L seat

- Measure the 0-torque of the valve. It should be acc. to Table 3.

0-torque shall be adjusted with graphite sheet rings (available thicknesses are 0.2 and 0.4 mm).

Table 3 0-torques

DN / NPS	0-torque (Nm / lbf ft)	
	1-seat	2-seat
50 / 2	20-50 / 15-37	50-100 / 37-74
80 / 3	50-100 / 37-74	150-200 / 110-148
100 / 4	100-150 / 74-110	200-250 / 148-184
150 / 6	150-200 / 110-148	250-300 / 184-221
200 / 8	200-250 / 148-184	300-350 / 221-258
250 / 10	250-300 / 184-221	350-400 / 258-295
300 / 12	300-350 / 221-258	400-450 / 295-332
350 / 14	350-400 / 258-295	450-550 / 332-405
400 / 16	400-500 / 295-368	550-650 / 405-479

Roughness of the surfaces in contact with graphite back seals shall be Ra 0.4 or better. Sharp edges shall be rounded off. Apply a thin and even layer of molybdenum grease spray on cleaned ball and seat surfaces before assembly.

- Place the O-ring (63) into the groove of the ball seat (7) and lubricate the O-ring (63) with silicone grease.
- Place the graphite back seals (196) onto the seat.
- Place seal ring (braided graphite) (129) into the groove of the ball seat.
- Place the ball seats into the body and the body cap using plastic or wooden mallet or if necessary, using a hydraulic press.

All versions:

- Place a trunnion bearing (99) into each trunnion plate (89) counterbore.
- Place a thrust bearing (91) over each ball trunnion.
- Fit a trunnion plate over each ball trunnion until the plate rests against the bearing spacer (91). This operation must be performed with care and without excessive force or the bearing will be damaged. It may be necessary to tap the plate on with a plastic mallet.
- Align the trunnion plates (89) relative to the ball port in the closed position.

NOTE:

The shaft will fit into the ball in one position only. There's a larger cog in the splined shaft or added cog in square end shaft and a matching groove in the ball shaft bore. It is essential to note the groove's position during the next assembly step.

- With the ball (3) in the "closed" position, lower the ball/trunnion plate subassembly into the body (1). In sizes DN450-600 / 18"-24", see that the trunnion plate pins (89A) are inserted in the Body (1). **NOTE:** This procedure is critical and careful attention is a must. The outside diameter of the trunnion plates must pilot in the body counterbore. In sizes DN450-600 / 18"-24", the pins (89A) need to align with the holes in trunnion plate (89). Carefully lower the subassembly until a trunnion plate enters the counterbore. In sizes DN450-600 / 18"-24" pins (89A) go inside the trunnion plate (89). (Usually one trunnion plate will enter the counterbore and the other will be out of position.) Use a plastic mallet or a block of wood to rotate the second trunnion into position. Once trunnion plates are aligned, lower the subassembly until the trunnion plates are seated in the bottom of the counterbore.

- Slide the thrust bearings (70 and 71) over the shaft (5). See the exploded view for proper orientation.

Sizes DN50 -400 / 02"-16"

- Insert shaft subassembly through the bonnet (8) and install packing (69). Refer to Fig. 8 for proper orientation of packing.
- Install the gland (9) over shaft (5) and gland studs. Install the disc springs sets (150) and the gland stud nuts (18) on studs and tighten "finger tight."
- Install the bonnet gasket (66) and the bonnet subassembly over the bonnet studs (13). Note the correct shaft position! Lubricate the threads of studs (13) and tighten the nuts (17) according to values in Table 4.

Sizes DN450 -600 / 18"-24"

- Insert shaft subassembly through the shaft bore of the body (1). Note the correct shaft position!
- Install the bonnet gasket (66) and then bonnet (8) and over the shaft and the bonnet studs (13). Lubricate the threads of studs (13) and tighten the nuts (17) according to values in Table 4.
- Install the packing (69). Refer to Fig. 11 for proper orientation of packing.
- Install the gland (9) over shaft (5) and gland studs. Install the disc springs sets (150) and the gland stud nuts (18) on studs and tighten "finger tight."

All sizes (DN50 - 600 / 02" - 24")

- Install the body gasket (65) in the body groove.
- Place the body cap (2) carefully over the body studs (12) and the body (1). See that the flange holes are aligned acc. to the mark made during the dismating. Take care not to damage the body gasket (65) and the seat (7) in the body cap.
- Fasten the body nuts (16). Tighten the nuts gradually, always switching to other side of the valve after every nut. The recommended torques are given in Table 3. The flange faces must be in even contact with each other.
- Mount the key (10).
- Cycle the valve slowly a couple of times to ensure correct position of the ball between the two seats.

Table 4 Tightening torques of the body joint bolting

Material	ASTM A320 gr. L7M	ASTM A193 gr. B8M cl. 1	ASTM A193 gr. B8M cl. 2
Bolt Size	Tightening Torque (Nm)	Tightening Torque (Nm)	Tightening Torque (Nm)
M8	25	11	31
M10	50	22	60
M12	85	38	100
M14	140	61	170
M16	210	95	260
M20	420	190	420
M24	720	320	720
M27	1100	480	870
M30	1400	650	1200
M36	2500	1100	1600
M39	3300	1500	2100

NOTE: Check the correct bolt material from valve bill of materials. If material is not shown above table, please consult the manufacturer.

NOTE: Threads must be well lubricated

NOTE: ASTM A193 B8M cl.1 utilized in sizes 2"-16", ASTM A193 cl.2 utilized in sizes 18"-24"

- Tighten the gland nuts (18) acc. to Section 4.2 . Pull on the shaft (5) while tightening to assure that shaft and thrust bearings are always in contact with the body. Check for leakage once the valve is pressurized..
- Install the valve in the pipeline as carefully and accurately as when removing it. Follow the instructions given in Section 3.

5. TESTING THE VALVE

CAUTION:

Pressure testing should be carried out using equipment conforming to the correct pressure class!

We recommend that the valve body be pressure tested after the valve has been assembled.

The pressure test should be carried out in accordance with an applicable standard using the pressure rating required by the pressure class or flange drilling of the valve. The valve must be in an half-open position during the test.

If you also want to test the tightness of the closure member, contact the manufacturer.

6. INSTALLING THE ACTUATOR

6.1 General

CAUTION:

Beware of ball cutting movement!

Different Neles actuators can be mounted using suitable brackets and couplings. The valve can be actuated by an M-handwheel operator or B1-series actuators.

Please use tightening torques given in table 5 when bolting the bracket on to valve.

Table 5 Tightening torques for bracket bolting (for lubricated screws) (Nm)

Screw / Material	M6	M8	M10	M12	M16	M20	M24	M30
A2-70/A4-70	8,6	21	41	70	170	340	590	1200
B8M Cl.1	4,7	11	22	38	95	190	320	650
Gr.660	11	27	53	91	230	440	770	1500

6.2 Installing the M-handwheel operator

- The mark at the end of the shaft indicates the direction of the ball flow bore. Turn the valve to the closed position.
- Lubricate the grooves of the actuator and the couplings. Place the coupling on the shaft and lock it. Place the bracket on the valve and turn the lubricated screws a few times.
- Turn the actuator to the closed position and push it carefully onto the valve shaft on which the coupling has been mounted. Please note the marks on the handwheel and the coupling.
- Lubricate the actuator screws. Tighten all screws.
- Adjust the ball open and closed positions with the hexagon screws located at the side of the housing (see Figure 17). The stop-screw for the open position is nearest to the handwheel on the side of the housing and the screw for the closed position is at the opposite end. The turning directions for the handwheel are marked on the wheel.
- Check the handwheel by turning the valve to the extreme positions. The yellow arrow should indicate the direction of the ball flow bore.

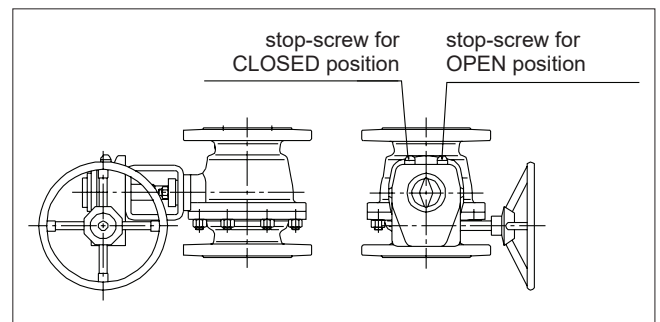

Fig. 17 Open and closed positions of the M actuator

6.3 Installing the B1C-series actuator

- Turn the valve to the closed position and drive actuator piston to the extreme outward position.
- File off any burrs and clean the shaft bore.
- The line at the end of the shaft indicates the direction of the ball flow bore.
- Lubricate the actuator shaft bore. Fasten the bracket loosely to the valve.
- Slip the actuator carefully onto the valve shaft. Avoid forcing it since this may damage the ball and seats. We recommend mounting the actuator so that the cylinder is pointing upwards.
- Position the actuator parallel or vertical to the pipeline as accurately as possible. Lubricate the actuator mounting screws and then fasten all screws.

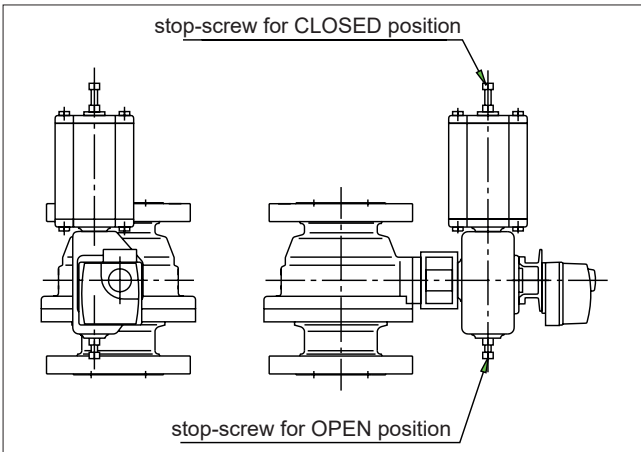

Fig. 18 Open and closed positions of the B1C/B1J actuator

- Adjust the ball open and closed positions by means of the actuator stop screws located at both ends (see Fig 18). An accurate open position can be seen in the body flow bore. Check that the yellow arrow on the actuator indicates the ball flow opening position. **Keep fingers out of the flow bore!**

There is no need for stop screw adjustment if the actuator is re-installed in the same valve. Drive actuator piston to the housing end (open position). Turn the stem by hand until the valve is in the open position. Fasten the actuator in this position as explained above.

- Check the stop screw thread tightness. An O-ring is used for sealing.
- Check that the actuator is functioning correctly. Drive the actuator piston to both cylinder ends and check the ball position and its movement with respect to the actuator (close: clockwise; open: counterclockwise). The valve should be closed when the piston is in the extreme outward position.
- If necessary, change the position of the actuator pointing cover to correctly indicate the valve open/closed position.

7. TROUBLE SHOOTING TABLE

The following Table 6 lists malfunctions that might occur after prolonged use.

Table 6 Trouble shooting

Symptom	Possible fault	Recommended action
Leakage through a closed valve	Wrong stop screw adjustment of the actuator	Adjust the stop screw for closed position
	Faulty zero setting of the positioner	Adjust the positioner
	Damaged seat	Replace seat
	Damaged closing member	Replace the closing member
Leakage through body joint	Closing member in a wrong position relative to the actuator	Select the correct keyway in the actuator
	Damaged gasket	Replace the gasket
Irregular valve movements	Loose body joint	Tighten the nuts or screws
	Actuator or positioner malfunction	Check the operation of the actuator and positioner
	Process medium accumulated on the sealing surface	Clean the sealing surfaces
	Closing member or seat damaged	Replace the closing member or seat
Gland packing leaking	Crystallizing medium has entered the bearing spaces	Flush the bearing spaces
	Gland packing worn or damaged	Replace the gland packing
	Loose packing	Tighten the packing nuts

8. TOOLS

In addition to standard tools, the following special tools might be needed.

- For removal of the actuator:
 - extractor (ID-code table in actuator's IMO)

This tool can be ordered from the manufacturer. Always give the valve type designation when ordering.

6.4 Installing the B1J-series actuator

Spring-return actuators are used in applications where valve opening or closing movement is needed in case the air supply is interrupted. The B1J type is used for spring-to-close operation; the spring pushes the piston towards the cylinder end, the extreme outward position. In turn, the B1JA type is used for spring-to-open operation; the spring pushes the piston towards the housing. Spring-return actuators are installed in a manner similar to B1C-series actuators, taking into account the following.

B1J type

- Install the actuator so that the piston is in the extreme outward position. The cylinder must not be pressurized and air supply connections must be open. The valve must be in the **closed** position.

B1JA type

- Install the actuator so that the piston is in the cylinder end position at housing side. The cylinder must not be pressurized and air supply connections must be open. The valve must be in the **open** position.

The rest of the installation procedure is the same as in Section 6.3.

6.5 Installing other makes of actuators

NOTE:

Valmet accepts no responsibility for compatibility of actuators not installed by Valmet.

Other actuators can be installed only if they have an ISO 5211 actuator connection.

9. ORDERING SPARE PARTS

When ordering spare parts, always include the following information:

- type code, sales order number, serial number
- number of the parts list, part number, name of the part and quantity required

This information can be found from the identification plate or documents.

10. EXPLODED VIEW AND PARTS LIST

Sizes 2"-16"

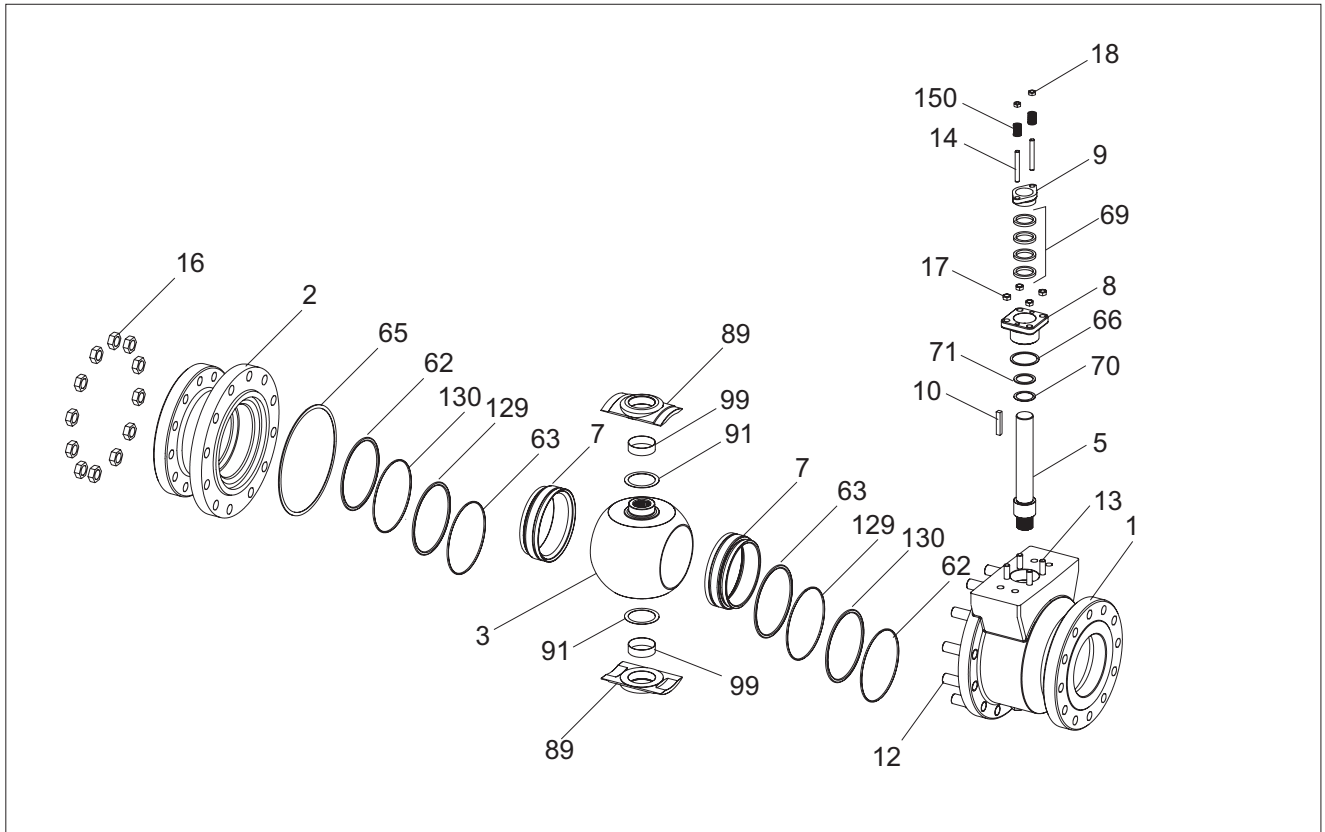

Item	Qty	Description	Spare part category
1	1	Body	
2	1	Body cap	
3	1	Ball	3
5	1	Shaft	3
7	1 or 2	Seat (A, B, D, H, K, L, S, T)	2
8	1	Bonnet	
9	1	Gland	
10	1	Key	3
12		Stud	
13		Stud	
14		Stud	
16		Hexagon nut	
17		Hexagon nut	
18		Hexagon nut	
62	1	Spring	1
63	1 or 2	O-ring (A, B, D, L, S, T)	1
	1	Back seal (H)	1
65	1	Body gasket	1
66	1	Bonnet gasket	1
69	1	Packing / V-ring set	1
70	2 or 3	Thrust bearing	3 (metal), 1 (soft)
71	3	Thrust bearing	3
75	1 or 2	Braided seal square (K, B)	1
89	2	Trunnion plate	
91	2	Bearing spacer	3 (metal), 1 (soft)
99	2	Trunnion bearing	3 (metal), 1 (soft)
129	1 or 2	Back seal (B, D, K, L)	1
130	1 or 2	Support ring (B, D, K)	2
150	2	Disc spring set	

Spare part category 1: (Spare Part Set): Recommended soft parts, always needed for the repair. Delivered as a set.

Spare part category 2: Parts for replacing of the seat. Available also as a set.

Spare part category 3: Parts for replacing of the closing element.

Spares for the full overhaul: All parts from the categories 1, 2 and 3.

Sizes 18"-24"

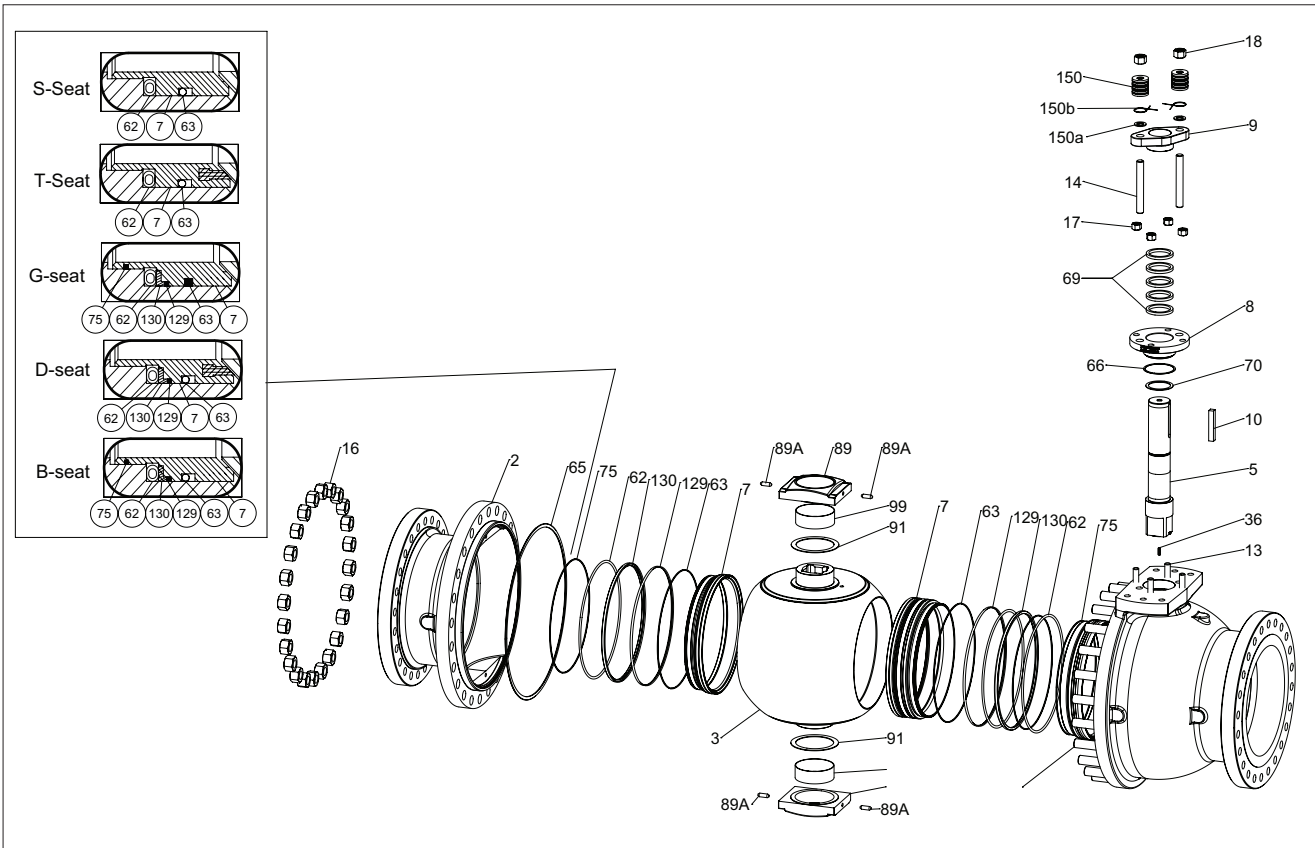

Item	Qty	Description	Spare part category
1	1	BODY	
2	1	BODY CAP	
3	1	BALL	3
5	1	SHAFT	3
7	1 or 2	SEAT (B, D, G, S, T)	2
8	1	BONNET	
9	1	GLAND	
10	1	KEY	3
12		STUD	
13		STUD	
14		STUD	
16		HEXAGON NUT	
17		HEXAGON NUT	
18		HEXAGON NUT	
19	1	IDENTIFICATION PLATE	
36	1	ANTI-STATIC SPRING	
62	1 or 2	SPRING	1
63	1 or 2	O-RING (B, D, S, T)	1
	1 or 2	BRAIDED SEAL SQUARE (G)	1
65	1	BODY SEAL SPIRAL WOUND	1
66	1	SHEET RING	1
69	1	PACKING RING/V-RING SET	1
70	1	THRUST BEARING	3 (metal), 1 (soft)
75	1 or 2	BRAIDED SEAL SQUARE (B, G)	1
89	2	TRUNNION PLATE	
89A	4	PIN	
91	2	THRUST BEARING	3 (metal), 1 (soft)
99	2	TRUNNION BEARING	3 (metal), 1 (soft)
129	1 or 2	BACK SEAL (G, B, D)	1
130	1 or 2	SUPPORT RING (G, B, D)	2
150	2	DISC SPRING SET	
150a	2	Washer	
150b	2	Torsion Spring	

11. DIMENSIONS

Valve is shown as open position.

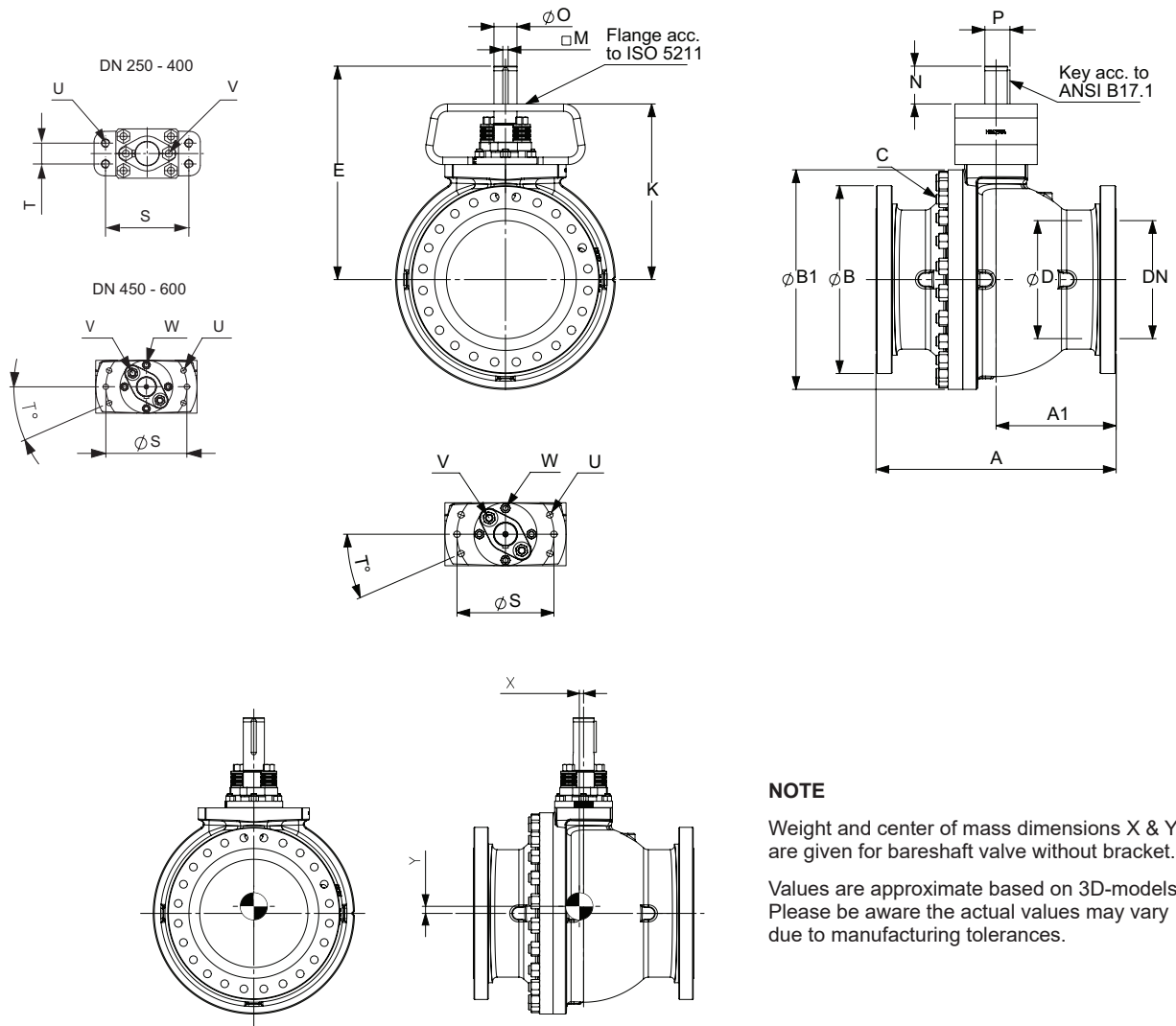

NOTE

Weight and center of mass dimensions X & Y are given for bare shaft valve without bracket.

Values are approximate based on 3D-models. Please be aware the actual values may vary due to manufacturing tolerances.

ASME 150

DN	ISO FLANGE	DIMENSIONS, mm										WEIGHT kg	CENTER OF GRAVITY DIMENSIONS, mm	
		A	A1	ØB	ØB1	ØD	E	K	□M	ØO	P		X	Y
50	F07, F10	178	79	150	146	50.8	203	168	4.76	20	22.16	10	11	13
80	F07, F10, F12, F14	203	96.5	190	190	76.2	225	190	4.76	20	22.16	22	9	11
100	F10, F12, F14	229	112	230	241	101.6	296	250	6.35	25	27.75	32	8	16
150	F14, F16	394	197	280	338	152.4	373	305	9.53	40	44.23	75	8	15
200	F14, F16, F25	457	229	343	426	203.2	453	385	9.53	40	44.23	190	9	14
250	F14, F16, F25, F30	533	267	407	514	254	562	472	12.7	55	60.6	325	13	23
300	F14, F16, F25, F30	610	305	483	592	304.8	605	515	12.7	55	60.6	480	17	24
350	F16, F25, F30, F35	686	343	533	665	340	741	607	19.05	75	83.15	635	18	35
400	F16, F25, F30, F35	762	381	597	750	390	779	633	22.23	85	94.63	840	15	31
450	F30, F35	864	457	635	800	436	793.9	645.7	22.23	85	95.68	1001	14	34
500	F30, F35	914	495.5	700	885	487	811	665	22.23	85	95.68	1304	10	26
600	F25, F30, F35, F40	1067	571.5	815	1041	589	987	831	22.23	95	105.87	2087	9	29

Face-to-face dimension acc. to ANSI B16.10, Table 1, long pattern

ASME 300

DN	ISO FLANGE	DIMENSIONS, mm										WEIGHT kg	CENTER OF GRAVITY DIMENSIONS, mm	
		A	A1	ØB	ØB1	ØD	E	K	□M	ØO	P		X	Y
50	F07, F10	216	89	165	146	50.8	203	168	4.76	20	22.16	15	18	10
80	F07, F10, F12, F14	282	141	210	200	76.2	225	190	4.76	20	22.16	32	6	7
100	F10, F12, F14	305	152	255	254	101.6	296	250	6.35	25	27.75	58	8	11
150	F14, F16	403	201	320	353	152.4	373	305	9.53	40	44.23	125	10	12
200	F14, F16, F25	502	249	380	462	203.2	453	385	9.53	40	44.23	225	13	10
250	F14, F16, F25, F30	568	284	445	552	254	562	472	12.7	55	60.6	330	21	16
300	F14, F16, F25, F30	648	324	520	652	304.8	605	515	12.7	55	60.6	610	24	17
350	F16, F25, F30, F35	762	381	585	700	340	741	607	19.05	75	83.15	800	22	26
400	F16, F25, F30, F35	838	419	650	799	390	779	633	22.23	85	94.63	1015	24	21
450	F30, F35	914	389.5	710	825	436	793.9	645.7	22.23	85	95.68	1235	20	27
500	F25, F30, F35, F40	991	457	775	906	487	881	725	22.23	95	105.87	1692	19	32
600	F35, F40	1143	533.5	915	1060	589	1090	885	31.75	120	136.54	2636	20	38

Face-to-face dimension acc. to ANSI B16.10, Table 1, long pattern

ASME 150

Size	ISO FLANGE	DIMENSIONS, inch										WEIGHT lbs	CENTER OF GRAVITY DIMENSIONS, inch	
		A	A1	ØB	ØB1	ØD	E	K	□M	ØO	P		X	Y
2	F07, F10	7.01	3.11	5.91	5.75	2	7.99	6.61	0.19	0.79	0.87	22	0.45	0.53
3	F07, F10, F12, F14	7.99	3.8	7.48	7.48	3	8.86	7.48	0.19	0.79	0.87	48.4	0.36	0.41
4	F10, F12, F14	9.02	4.41	9.06	9.49	4	11.65	9.84	0.25	0.98	1.09	70.4	0.32	0.65
6	F14, F16	15.51	7.76	11.02	13.31	6	14.69	12.01	0.38	1.57	1.74	165	0.31	0.60
8	F14, F16, F25	17.99	9.02	13.5	16.77	8	17.83	15.16	0.38	1.57	1.74	418	0.35	0.54
10	F14, F16, F25, F30	20.98	10.51	16.02	20.24	10	22.13	18.58	0.5	2.17	2.39	715	0.51	0.90
12	F14, F16, F25, F30	24.02	12.01	19.02	23.31	12	23.82	20.28	0.5	2.17	2.39	1056	0.66	0.96
14	F16, F25, F30, F35	27.01	13.5	20.98	26.18	13.39	29.17	23.9	0.75	2.95	3.27	1397	0.71	1.37
16	F16, F25, F30, F35	30	15	23.5	29.53	15.35	30.67	24.92	0.88	3.35	3.73	1848	0.60	1.21
18	F30, F35	34.02	17.99	25	31.5	17.17	31.26	25.42	0.88	3.35	3.77	2224	0.55	1.35
20	F30, F35	35.98	19.51	27.56	34.84	19.17	31.93	26.18	0.88	3.35	3.77	2898	0.40	1.04
24	F25, F30, F35, F40	42.01	22.5	32.09	40.98	23.19	38.86	32.72	0.88	3.74	4.17	4638	0.36	1.16

Face-to-face dimension acc. to ANSI B16.10, Table 2, long pattern

ASME 300

Size	ISO FLANGE	DIMENSIONS, inch										WEIGHT lbs	CENTER OF GRAVITY DIMENSIONS, inch	
		A	A1	ØB	ØB1	ØD	E	K	□M	ØO	P		X	Y
2	F07, F10	8.5	3.5	6.5	5.75	2	7.99	6.61	0.19	0.79	0.87	33	0.70	0.41
3	F07, F10, F12, F14	11.12	5.55	8.25	7.87	3	8.86	7.48	0.19	0.79	0.87	70	0.22	0.26
4	F10, F12, F14	12	6	10	10	4	11.65	9.84	0.25	0.98	1.09	128	0.32	0.44
6	F14, F16	15.88	7.93	12.5	13.9	6	14.69	12.01	0.38	1.57	1.74	276	0.38	0.46
8	F14, F16, F25	19.75	9.8	15	18.19	8	17.83	15.16	0.38	1.57	1.74	496	0.51	0.40
10	F14, F16, F25, F30	22.38	11.18	17.5	21.73	10	22.13	18.58	0.5	2.17	2.39	727	0.82	0.64
12	F14, F16, F25, F30	25.5	12.76	20.5	25.67	12	23.82	20.28	0.5	2.17	2.39	1345	0.94	0.68
14	F16, F25, F30, F35	30	15	23	27.56	13.4	29.17	23.9	0.75	2.95	3.27	1764	0.88	1.04
16	F16, F25, F30, F35	33	16.5	25.5	31.46	15.4	30.67	24.92	0.88	3.35	3.73	2237	0.96	0.82
18	F30, F35	35.98	15.33	27.95	32.48	17.17	31.26	25.42	0.88	3.35	3.77	2744	0.78	1.07
20	F25, F30, F35, F40	39.02	17.99	30.51	35.67	19.17	34.69	28.54	0.88	3.74	4.17	3760	0.76	1.26
24	F35, F40	45	21	36.02	41.73	23.19	42.91	34.84	1.25	4.72	5.38	5858	0.78	1.49

EN PN 10 - 40

Type	DN	DIMENSIONS, mm																WEIGHT kg	CENTER OF GRAVITY DIMENSIONS, mm		
		ØD	A	A1	ØB	ØB1	E	K	M	N	ØO	P	S	T	U	V	W		C	X	Y
PN10	450	436	864	432	615	800	794	648	22.23	146	85	94.63	330	21.3	M30	M20	M20	M27	981	14	36
	500	487	914	457	670	885	811.5	665.5	22.23	146	85	94.63	330	21.3	M30	M20	M20	M27	1288	10	27
	600	589	1067	533.5	780	1041	987	831	22.23	156	95	105.87	400	23.6	M30	M30	M24	M30	2037	10	30
PN16	450	436	864	432	640	800	794	648	22.23	146	85	94.63	330	21.3	M30	M20	M20	M27	1011	14	35
	500	487	914	457	715	885	811.5	665.5	22.23	146	85	94.63	330	21.3	M30	M20	M20	M27	1328	10	26
	600	589	1067	533.5	840	1041	987	831	22.23	156	95	105.87	400	23.6	M30	M30	M24	M30	2141	9	29
PN25	450	436	914	457	710	785	794	648	22.23	146	85	94.63	330	21.3	M30	M20	M20	M36	1249	14	32
	500	487	991	495.5	775	880	881	725	22.23	156	95	105.87	400	23.6	M30	M30	M24	M39	1692	13	27
	600	589	1143	571.5	915	1050	1090	885	31.75	205	120	136.54	460	23.6	M30	M30	M24	M39	2636	10	28
PN40	450	436	914	457	710	825	794	648	22.23	146	85	94.63	330	21.3	M30	M20	M20	M36	1249	21	28
	500	487	991	495.5	775	906	881	725	22.23	156	95	105.87	400	23.6	M30	M30	M24	M39	1692	20	33
	600	589	1143	571.5	915	1060	1090	885	31.75	205	120	136.54	460	23.6	M30	M30	M24	M39	2636	20	39

12. TYPE CODE

1.	2.	3.	4.	5.	6.	7.	8.	9.	10.	11.
XG	06	D	W	TA	J2	PJ	S	A	B	T

1.	VALVE SERIES & STYLE & FACE-TO-FACE
XG	Full bore, trunnions, f-to-f ASME B 16.10, Table 2, long pattern, ASME 300
XM	Full bore, trunnions, f-to-f ASME B 16.10, Table 1, long pattern, ASME 150

6.	BODY MATERIAL
J2	ASTM A216 gr WCB (Carbon Steel)
S6	ASTM A351 gr CF8M (Stainless Steel)
J5	ASTM A217 gr C5 (Low Alloy Steel)

2.	SIZE			
ASME valves with metric threads		EN valves with metric threads		
	NPS		DN / mm	
02	2"	050	50	
03	3"	080	80	
04	4"	100	100	
06	6"	150	150	
08	8"	200	200	
10	10"	250	250	
12	12"	300	300	
14	14"	350	350	
16	16"	400	400	
18	18"	450	450	
20	20"	500	500	
24	24"	600	600	

7.	BALL / COATING & STEM MATERIAL
PJ	316SS / Hard Chrome & 17-4PH
PP	316SS & 17-4PH (soft seats, ball without coating)
PV	316SS/Tungsten carbide, TC2
PL	316SS / NiBo & 17-4PH
PX	316SS / Chrome carbide & 17-4PH
SJ	316SS / Hard Chrome & XM-19 (Nitronic 50)
SP	316SS & XM-19 (Nitronic 50) (soft seats, ball without coating)
RX	316SS / CrC (Chrome carbide) & XM-19 (Nitronic 50), only with metal bearings.
RR	316SS / WC-Co (Tungsten carbide) & XM-19 (Nitronic 50)
SL	316SS / NiBo & XM-19 (Nitronic 50)
SW	410SS / Chrome carbide & XM-19 (Nitronic 50)

17-4PH stem material required to comply API 608 stem strength, limitations may apply in XG size 8" & 12", see instructions after sign 11.

Balls with coating are used in metal seated valves.

Max temperatures for coatings:

- Hard Chrome (HCr): 450 °C
- Tungsten carbide (WC-Co): 450 °C
- Chrome carbide (CrC/CrC-LF): 600 °C

If seat coating is Chrome Carbide, CrC-LF, then use Chrome Carbide, CrC as ball coating.

3.	PRESSURE CLASS
C	ASME Class 150 (Use XM, size NPS 2"...24").
D	ASME Class 300 (Use XG, size NPS 2"...24").
J	PN 10 (Use XM, sizes DN200 ... DN600).
K	PN 16 (Use XM, sizes DN100 ... DN600).
L	PN 25 (Use XG, size DN200 ... DN600).
M	PN 40 (Use XG, size DN50 ... DN600).

8.	SEAT AND BACK SEAL TYPES / SPRING MATERIALS		
	Seat type	Back seal	Spring
S	metal, general service	O-ring	Inconel 625
B	metal, solid proof, firesafe	Graphite + O-ring	Inconel 625
K	metal, solid proof, high temp, firesafe	Graphite + Graphite	Inconel 625
G	metal, solid proof, high temp, firesafe	Graphite + Graphite	Inconel 625
L	metal, polymer proof	Graphite + O-ring	-
H	metal, bellows	Graphite	-
T	soft, general service	O-ring	Inconel 625
D	soft, firesafe service	Graphite + O-ring	Inconel 625

4.	END CONNECTION STYLE
W	raised face, ASME B 16.5 (Ra 3.2-6.3), standard with ASME rated flanges.
C	EN 1092-1 Type B1, (Ra 3.2 – 12.5), standard with EN rated flanges.

5.	CONSTRUCTION & APPLICATION
TA	Standard construction. Double seated. Live loaded packing.
TE	Single seated. Otherwise standard.
TQ	Q-Trim construction. Otherwise standard.
EQ	Single seated, Q-Trim construction.
2G	Q2G-trim for gas application, single seated, otherwise standard.
2H	Q2G-trim for gas application, HIGH CAPACITY version.
TZ	BAM tested non-metallic materials, for oxygen service. Double seated. Metal bearings. Live loaded graphite packing. Temperature range -50...+200C. Max pressure based on body rating. Oxygen cleaning acc. to Neles internal procedure FC-QC-0001included.

9.	SEAT MATERIAL	
	Metal seats	
	Seat material	Coating
A	Type 316 stainless steel (S, B, K, G, L seats), AVESTA 248SV (H seats)	Cobalt based hard facing
B	Type 316 stainless steel (S, B, K, G, L seats), AVESTA 248SV (H seat)	Chrome Carbide, CrC-LF
V	Type 316 stainless steel with S, B, K and L type seats AVESTA 248SV with H type seat.	Tungsten Carbide, TC2
R	Type 316 stainless steel (S, B, K, G, L seats), AVESTA 248SV (H seats)	Tungsten Carbide, WC-CO
Z	Type 410 stainless steel (S, B, K, G, L seats)	Tungsten Carbide, WC-Co
W	Type 410 stainless steel (S, B, K, G, L seats)	Chrome Carbide, CrC-LF
F	F6NM (H seat for high temp. NACE service)	Chrome Carbide, CrC-LF
D	Inconel 718 with H type seat	Tungsten Carbide, WC-Co
Soft seats		
	Seat material	Insert
T	Type 316 stainless steel	PTFE
M	Type 316 stainless steel	Filled PTFE
P	Type 316 stainless steel	PEEK
N	Type 316 stainless steel	Polyamid
L	Monel	Filled PTFE

10.	BEARING AND SEAL MATERIALS				
	Trunnion bearing	Packings	Body gaskets	O-ring	Thrust bearing
A	Reinforced PTFE	V-rings PTFE	PTFE	Viton GF	Metal
B	Reinforced PTFE	Graphite	Graphite	Viton GF	Metal
C	Stellite	V-rings PTFE	PTFE	Viton GF	Metal
D	Stellite	Graphite	Graphite	Viton GF	Metal
H	Reinforced PTFE	V-rings PTFE	PTFE	EPDM	Metal
S	Reinforced PTFE	Graphite	Graphite	EPDM	Metal
U	SS + WC-CO	Graphite	Graphite	Viton GF	Metal
V	SS + WC-CO	Graphite gr.GTA	Graphite	Viton GF	Metal
T	SS + WC-CO	Braided PTFE	Graphite	Viton GF	Metal

11. sign	Bolting material with metric thread				
	Pressure retaining		Packing gland bolting		
	Standard	Studs	Nuts	Studs	Nuts
E*	B8M	8M	gr. 660	gr. 660	-200 ... +538 °C
T**	L7M	2HM	B7	2H	-40 ... +538 °C
S**	L7M	2HM	gr. 660	gr. 660	-46 ... +538 °C
D*	B8M	B8	B8M	8M	-200 ... +800 °C
F**	L7M	2HM	L7M	2HM	-46 ... +538 °C
Non Standard	Studs	Studs	Studs	Nuts	Temp range
A**	B7	2H	B7	2H	-40 ... +538 °C
B*	B8	8	B8	8	-200 ... +800 °C
G**	B7M	2HM	B7M	2HM	-200 ... +260 °C

EN/ISO bolting materials are obsolete. ASME bolting materials can be used in EN rated valves.

* Bolting materials for stainless steel body

** Bolting materials for carbon and low alloy steel body

13. GENERAL SAFETY WARNINGS AND DISCLAIMERS

General safety warnings

Lifting

1. Always use a lifting plan created by a qualified person to lift this equipment. Lifting guidance is provided in this IMO (Installation, Maintenance and Operation manual) to assist in lifting plan development. Think about the center of gravity (CG) of the equipment being lifted. Make sure the CG is always under the central lifting point.
2. Valves may be equipped with lifting threads on the body or on the flanges. These are intended to be used with the lifting plan.
3. Use only correct and approved lifting devices. Ensure that lifting devices and straps are securely attached to the equipment prior to lifting.
4. Check, that lifting devices are not damaged and in good condition with a valid check stamp prior to use.
5. Workers must be trained for lifting and handling valves.
6. Never lift an assembly by the instrumentation (solenoid, positioner, limit switch, etc.) or by the instrumentation piping. Straps and lifting devices should be fitted to prevent damage to instrumentation and instrumentation piping. Failure to follow the lifting guidance provided may result in damage and personal injury from falling objects.

Work activities on the valve

1. Wear your personal safety equipment. Personal safety equipment includes but is not limited to protective shoes, protective clothing, safety glasses, helmet, hearing protection and working gloves.
2. Always follow the local safety instructions in addition to the Valmet instructions. If Valmet instructions conflict with local safety instructions, stop work and contact Valmet for more information.
3. Before beginning service on the equipment, make sure that the actuator is disconnected from any kind of power source (pneumatic, hydraulic, and/or electric), and no stored energy is applied on the actuator (compressed spring, compressed air volumes, etc.). Do not attempt to remove a spring return actuator unless the stop screw is carrying the spring force.
4. Make sure that there is a LOTOTO (Lock Out / Tag Out / Try Out) procedure in place for the system in which the valve is installed and strictly follow it.
5. Always make sure that the pipeline is depressurized and in ambient temperature condition before maintenance work is started.
6. Keep hands and other body parts out of the flow port when the valve is being serviced and the actuator is connected to the valve. There is a high risk of serious injury to hands and/or fingers due to malfunction if the valve suddenly starts to operate.
7. Beware of Trim (Disc, Ball or Plug) movement even when the valve is disassembled. Trim may move simply due to the weight of the part or change in position of the valve. Keep hands or other body parts away from locations where they may be injured by movement of the trim. Do not leave objects near or in the valve port which may fall in and need to be retrieved.

General disclaimers

Receiving, handling and unpacking.

1. Respect the safety warnings above!
2. Valves are critical components for pipelines to control high pressure fluids and must therefore be handled with care.

3. Store valves and equipment in a dry and protected area until the equipment is installed.
4. Do not exceed the maximum storage temperatures given in the IMO (installation, maintenance, and operating instructions).
5. Keep the original packaging on the valve as long as possible to avoid environmental contamination by dust, water, dirt, etc.
6. Remove the valve endcaps just before mounting into the pipeline.
7. FOR YOUR SAFETY IT IS IMPORTANT TO FOLLOW THESE PRECAUTIONS BEFORE REMOVAL OF THE VALVE FROM THE PIPELINE OR ANY DISASSEMBLY:
 - Be sure you know what flow medium is in the pipeline. If there is any doubt, confirm with the proper supervisor.
 - Wear any personal protective equipment (PPE) required for working with the flow medium involved in addition to any other PPE normally required.
 - Depressurize the pipeline, bring to ambient temperature, and drain the pipeline flow medium.
 - Cycle the valve to relieve any residual pressure in the body cavity.
 - After removal but before disassembly, cycle the valve again until no evidence of trapped pressure remains.
 - The valves with offset shaft (Butterfly, eccentric rotary plug) have greater trim area on one side of the shaft. This will cause the valve to open when pressurized from the preferred direction without a locking handle or an actuator installed.
 - **WARNING:** DO NOT PRESSURIZE THE ECCENTRIC VALVE WITHOUT A HANDLE OR AN ACTUATOR MOUNTED ON IT!
 - **WARNING:** DO NOT REMOVE A HANDLE OR AN ACTUATOR FROM AN ECCENTRIC VALVE WHILE PRESSURIZED!
 - Before installing the eccentric valve in or remove it from the pipeline, cycle the valve closed. Eccentric valves must be in the closed position to bring the trim within the face to face of the valve. Failure to follow these instructions will cause damage to the valve and may result in personal injury.

Operating

8. The identification plate (ID-plate, type plate, nameplate, or engraved markings) on the valve gives the information of max. process conditions to the valve.
9. (For soft seats) The practical and safe use of this product is determined by both the temperature and pressure ratings of the seat and body. Read the identification plate and check both ratings. This product is available with a variety of seat materials. Some seat materials have pressure ratings that are lower than the body ratings. All body and seat ratings are dependent on the valve type, size and material of the body and seat. Never exceed the marked rating.
10. Temperatures and pressures must never exceed values marked on the valve. Exceeding these values may cause uncontrolled release of pressure and process medium. Damage or personal injury may result.
11. The operating torque of the valve may rise over time due to wear, particles or other damage of the seat. Never exceed the actuator torque preset values (air supply, position). Application of excessive torque may cause damage to the valve.
12. Valmet valves typically are designed to be used in atmospheric conditions. Do not use valves under external pressurized conditions unless specifically designed and explicitly marked for this service.

13. Avoid Pressure shocks or water hammer. Systems with high pressure valves should be equipped with a bypass to reduce the differential pressure before opening the valve to avoid pressure shock.
14. Avoid thermal shock. High temperature, Low temperature and cryogenic valves should be operated in a way that limits the rate of increase or decrease in temperature. The valve should be thermally stabilized before being pressurized.
15. Materials of the valve are carefully selected for the process conditions. Changes to the process media can have a major impact on function and safety of the valve. Always confirm the materials are suitable for the service prior to installation.
16. As the use of the valve is application specific, several factors should be considered when selecting a valve for a given application. Therefore, some situations in which the valves are used are outside the scope of this manual.
17. It is the end user's responsibility to confirm compatibility of the valve materials with the intended service, however if you have questions concerning the use, application, or compatibility of the valve for the intended service, contact Valmet for more information.
18. Never use a valve with enriched or pure oxygen if the valve is not explicitly designed and cleaned for oxygen. Selected materials and design have a major impact on the safety to operate the valve with oxygen.
19. Valves intended for use in or with explosive atmospheres must be equipped with a grounding device and marked according ATEX (or equivalent international standards).
20. Manual handles are available for specific butterfly valve sizes and maximum line pressures. Do not operate a valve with a handle or wrench outside the size and pressure limits stated in the IMO. High line pressure may create a large enough force to pull the handle from the operator's hands. Damage or personal injury may result.
29. Do not use sharp tools, grinding machines, or files to work on functional surfaces such as sealing, seating or bearing surfaces as this can damage these surfaces.
30. Check the condition of sealing surfaces on the seats, trim (disc, ball, plug, etc.), body and body cap. Replace parts if there are significant wear, scratches, or damage.
31. Check the wear of bearings and bearing contact surfaces on the shaft and replace damaged parts if necessary.
32. Do not weld on pressure retaining parts without an ASME and PED qualified procedure and personnel.
33. Pressure retaining parts of valves in high temperature applications must be carefully examined for the effects of material creep and fatigue.
34. Make sure that the valve is positioned in the correct flow direction into the pipeline.
35. If the valves are marked to be suitable for explosive atmospheres, the correct function of the discharging device must be tested before returning to service.
36. Always work in a clean environment. Avoid getting particles inside the valve due to machining, grinding, or welding nearby.
37. Never store a valve in maintenance without flow port protection.
38. When pressure testing valve seats, never exceed the maximum operating pressure of the system or the maximum shut-off pressure marked on the valve identification plate.
39. Actuator mounting and unmounting:
 - Before installing the actuator on to the valve, be sure the actuator is properly indicating the valve position. Failure to assemble these to indicate correct valve position may result in damage or personal injury.
 - When installing or removing a linkage kit, best practice is to remove the entire linkage assembly, including couplings which may fall off the valve during lifting or when position changes.
 - Mounting sets have been designed to support the weight of the Valmet actuator and recommended accessories either as is or with additional actuator support. Use of the linkage to support additional equipment or additional weight such as people, ladders, etc. may result in equipment damage or personal injury.

Maintenance

21. Respect the safety warnings above!
22. Plan service and maintenance actions, that spare parts, lifting devices and service personnel is available.
23. Maintain the valve within the recommended minimum maintenance intervals or within the recommended maximum operating cycles.
24. Always make sure that the valve and the pipeline is depressurized before starting any kind of maintenance work at a valve.
25. Always check the position of the valve before starting maintenance work. Follow the Lock out /tag out (LOTO) rules at the site before starting any maintenance activity.
 - See IMO for the correct stem position.
 - Consider that the positioner may give the wrong signals.
26. Sealing materials (soft sealing parts) should be changed when the valve in maintenance. Always use original equipment manufacturers (OEM) spare parts to ensure proper performance of the repaired valve.
27. All pressure containing parts must be inspected visually for damage or corrosion. Damaged parts must be replaced.
28. Valve pressure retaining parts and all internals must be inspected for corrosion or erosion which may result in reduced wall thickness on pressure retaining parts. Damaged pressure retaining parts must be replaced with original equipment manufacturer's (OEM) replacement parts or repaired to factory specifications by an authorized Valmet service partner in order to maintain the warranty.
40. The valve should be installed between flanges using appropriate gaskets and fasteners that are compatible with the application, and in compliance with applicable piping codes and standards. Center the gaskets carefully when fitting the valve between the flanges. Do not attempt to correct pipeline misalignment by means of the flange bolting.
41. Repairs on valves for special service like Oxygen, Chlorine, and Peroxide, have special requirements.
 - Parts must be cleaned appropriate to the service and protected from contamination prior to assembly.
 - Assembly areas and tools must be clean and dry to prevent contamination of the parts during assembly.
 - Test equipment must be clean and dry to prevent contamination during testing. This includes the test equipment internals that may allow particles or other contamination into the test medium during the test.
 - Lubrication shall be used only if specifically required in the instructions. Where lubrication is required, the lubricant must be approved for the service by the end user.

Valmet Flow Control Oy

Vanha Porvoontie 229, 01380 Vantaa, Finland.

Tel. +358 10 417 5000.

www.valmet.com/flowcontrol

Subject to change without prior notice.

Neles, Neles Easyflow, Jamesbury, Stonel, Valvcon and Flowrox, and certain other trademarks, are either registered trademarks or trademarks of Valmet Oyj or its subsidiaries in the United States and/or in other countries.

