



Index

I. Scope 2

II. Applicability 2

III. Storage 2

IV. Installation 2

 i. Installation of end connections 3

 Installation of welded end ball valves 3

V. Operation 3

VI. Maintenance 4

 i. Preventive maintenance 4

 ii. Corrective maintenance 4

 Disassembly Instructions 4

 Replacement and Reassembly Instructions 4

 iii. Disposal 6

VII. Exploded parts view 7

I. Scope

This manual intends to assist the customers or the end users in storage, installation, operation and maintenance of Vinco ball valves. Subsequent additions and special instructions to the present manual will be provided in case of specific customer requirements and/or critical services.

This manual shall be analyzed before any procedure. Additional information can be requested through email at vinco@vincovalves.com.

II. Applicability

The Table 1 – Sizes and pressure classes identifies the range available in this series.

Table 1 – Sizes and pressure classes

DN				Pressure classes		
FB		RB		150	300	600
½"	15	¾"	20	-	-	x
¾"	20	1"	25	-	-	x
1"	25	1¼"	32	-	-	x
1¼"	32	1½"	40	-	-	x
1½"	40	2"	50	-	-	x
2"	50	2½"	65	-	-	x
2½"	65	3"	80	-	x	-
3"	80	4"	100	-	x	-
4"	100	-	-	-	x	-
6"	150	-	-	x	-	-

III. Storage

If the valves are **not intended to immediate use** follow the next recommendations to prevent any damage:

- It is advisable to keep the valves in the original packing in a dry place during all the storage period, protecting against environments like: humidity, rain, dust, dirt, sand, mud, salt air and seawater;
- The valves shall remain in the open position to prevent damaging the seats;
- When the valves are stored for a long period of time, they should be checked with a periodicity of six months;
- The internal surfaces of the valves shall be inspected to guarantee the absence of dust or other foreign parts;
- The valve should be operated for at least two complete cycles before re-store.

IV. Installation

Cautions before installation of the valves:

- The valve should be checked for possible transport or storage damages. Inspect the interior to assure cleanliness and that is free of dust or other residues;
- The valve should be in the **OPEN** or **CLOSED** position to prevent seat damage;
- During the cleaning operations, be aware of using an adequate solvent to prevent damage to the seats or others. Note that the packed valves are already degreased;
- Pay attention that the valve is unidirectional so the position in the installation is essential to guarantee the correct operation. The extension has a flow direction indicator and the position of the ball is marked on the top of the stem. The ball has also an upstream relief hole that needs to be installed facing the upstream side. See the details on the Figure 5 – Ball and internal seals assembly and Figure 6 – Exploded parts view;
- Verify that the application does not exceed the pressure and the temperature limits available on the nameplate or in the product datasheet;
- The valve should be preferable installed in vertical position. Either way it is allowed to be rotated from the vertical up to 25° for short extension version or 75° for the long extension version according to Figure 1 – Recommendation for alignment of the extension;
- The valve cannot be modified without a prior permission and/or recommendation of the manufacturer.

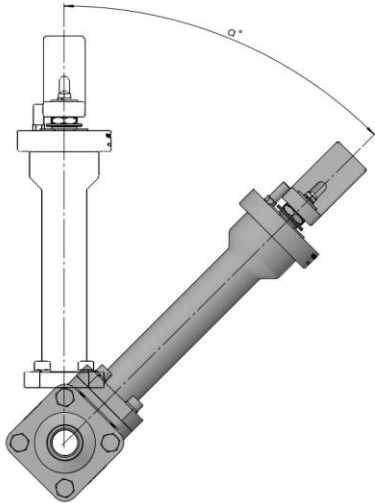

Figure 1 – Recommendation for alignment of the extension

i. Installation of end connections

The project of the installation shall assure adequate supports to avoid tension as flexion, torsion or other. on the valves, to prevent damage and the occurrence of internal or external leakage.

Installation of welded end ball valves

Short ends

1. Unscrew the end connections from the body to prevent that the welding operation damage the polymeric seals;
2. Position the pipe and the end connection and weld four points;
3. Ensure the right position and complete the welding operation;
4. After the welding operation it is important to clean the parts to remove the welding residues to prevent possible damage to the internal parts of the valve;
5. Refit the valve body to the welded end connections and tighten the bolting system according to Table 6 – Body bolting system Torque [Nm];
6. In the first operation it is important to verify the existence of external leakage, because of damage or bending, near to the body/end interface due to the welding operation.

Long ends

1. Position the pipe and the end connection and weld four points;
2. Ensure the right position and complete the welding operation without disassembling the valve;
3. After the welding operation it is important to operate the valve to **OPEN** position and clean the interior removing the welding residues to prevent possible damage on internal parts of the valve.

V. Operation

- After installation, operate the lever to open and close the valve. If it offers resistance, it should be necessary to disassemble the valve for adjust the position of the ball or to check any damage on the stem bearings and packing. This is more frequent in the welded short ends because of the disassemble of the body which can move the ball;
- Before starting continuous operation of the valve, it is advisable to pressurize the line to the service conditions. Check that installation is correct and do not have any leakage;
- If available, measure the valve torque comparing it with the nominal torque presented in Table 2 – Valve Torque Figure [Nm]. Note that nominal torque is measured at fully differential pressure considering liquid nitrogen at -196°C, which may result in a different torque than the torque measured at the service conditions;

Table 2 – Valve Torque Figure [Nm]

DN		Break Torque*
FB	RB	TFM 1600
15	20	15
20	25	25
25	32	35
32	40	70
40	50	110
50	65	125
65	80	250
80	100	400
100	-	700
150	-	1100

* at full differential pressure

- To maximize a longer life of the seats, the valve should be used in complete **OPEN** or **CLOSED** position;
- The valve is in the fully opened position when the handle is in line with the pipe. In the fully closed position, the handle is perpendicular to the pipe;
- In processes with significant service pressure variation, it is important to note that some internal leakage can occur for a certain period, especially when the pressure goes from high to low levels. This is a consequence of the seat deformation which requires some stabilization time to allow the elastic recovery of the seats.

VI. Maintenance

This chapter intends to help the end user maintaining the valve working in good conditions. There are presented two maintenance programs: preventive and corrective.

It is advisable to follow the next recommendations to ensure proper functionalities of the valve:

- After 25000 cycles check the stem tightness;
- After 50000 cycles change the internal seals;
- After 250000 cycles discard the valve.

i. Preventive maintenance

Every six months¹ it is advisable to check the general conditions of the valve. This evaluation shall be performed with the valve in line at the service conditions. Some steps should be performed to check the correct working of the valve:

1. Check for damage as corrosion in the valve. If severe corrosion is installed it is advisable to replace the valve;
2. Check for leakage between the body (1) and the end connection (2), body (1), extension (3) and iso flange (4) as well on the top of the stem (6). If necessary, retighten the bolting systems according to Table 3 to Table 6, under specifications of Replacement and Reassembly Instructions. If leakage remains, the valve should be disassembled to verify and/or replace the sealing components. Attend to next subchapter for instructions.

ii. Corrective maintenance

If the valve presents leakage, defect and/or malfunction it is advisable to disassemble the valve to check the conditions of the components and seals. Disassembly, replacement and reassembly instructions are detailed below to aid identification defects and replacement needs to ensure optimal service conditions. To guide the instructions, attend to Figure 6 – Exploded parts view.

Disassembly Instructions

1. The valve shall be in the **OPEN** position;
2. Depressurize the line and remove the valve;
3. Untighten the body bolting (30) and separate the body (1) from the end connections (2). Remove the seats (7) and the body seals (8,9);
4. Place the valve in the **CLOSED** position and remove the ball (5). Note that this is the only allowable position to perform this operation;

5. Untighten the handle fastener (27) and remove the handle (26).
6. Untighten the extension bolting (28) and separate the extension (3) from the body (1). Carefully remove the seals (10,11) and the bearing (15);
7. Remove the locking clip (25), untighten the stem nut (24) and remove the disc springs (23).
8. Untighten the bolting (29) and carefully remove the stem (6);
9. Separate the iso flange (4) from the extension (3);
10. Remove the washer (16), the packing (17) and the seal (19). Remove the bearing (21), the washer (18) and the fire safe packing (20, 22) from the iso flange (4);
11. The nameplate shall not be removed.

With the valve fully disassembled check all components for any defect, corrosion signs and mechanical damage. Clean the components.

Replacement and Reassembly Instructions

After disassembly some components should be analyzed in detail and replaced if damaged:

- The sealing components (ex: seats, seals and packing) should be replaced;
- The ball should be replaced if any defect is found in its surfaces;
- If extra torque is the main cause for the disassemble, check for any damage on the stem (6), iso flange (4), and extension (3) and on the sealings, packing and bearing parts.
- The nameplate should be replaced if information is unreadable.

Other components can be also check and replaced depending on the damage presented. Repair kits can be supplied upon request. Contact vinco@vincovalves.com for additional information.

After maintenance and replacement, the valve should be reassembled according to the following instructions:

1. Assemble the bearings (12,13) into the stem (6) and place the pin (14);
2. Insert the stem (6) into the extension (3) and hold it to prevent damage;
3. Place the washer (16), the packing (17) into the extension (3);

¹ The time between inspections may vary depending on the operating conditions.

- Place the seal (19) into the iso flange (4) and tighten with the bolting (29) according to Table 3 – Packing bolting system Torque [Nm]. After tightening verify that the iso flange (4) is completely in contact with the extension as shown in Figure 2 – Stem, extension and iso flange assembly It may be required to press down the iso flange and re-tighten to ensure the correct position of the iso flange (4);

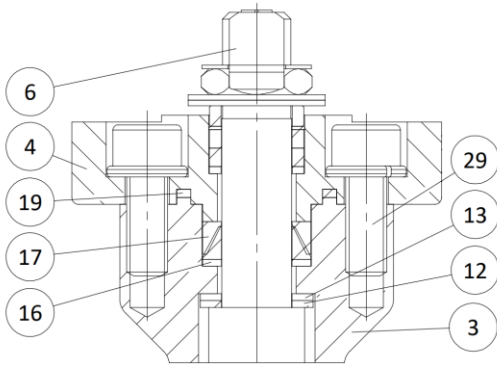

Figure 2 – Stem, extension and iso flange assembly

Table 3 – Packing bolting system Torque [Nm]

DN		Md	Torque
FB	RB		
15	20	5	6.5
20	25	5	6.5
25	32	5	6.5
32	40	5	6.5
40	50	5	6.5
50	65	8	17.5
65	80	10	30
80	100	10	30
100	-	12	50
150	-	12	50

- Place the first seal (10) into the extension (3) and the second seal (11) and the bearing (15) into the body (1) – Figure 3 – Extension and body assembly. Carefully place the extension set (3) on top of the body (1), to avoid damaging the seals and the bearing. Rotate the stem (6) and the extension (3) to ensure no sealing is broken or malfunctioning. Tighten the bolting (28) according to Table 4 – Extension bolting system torque [Nm];

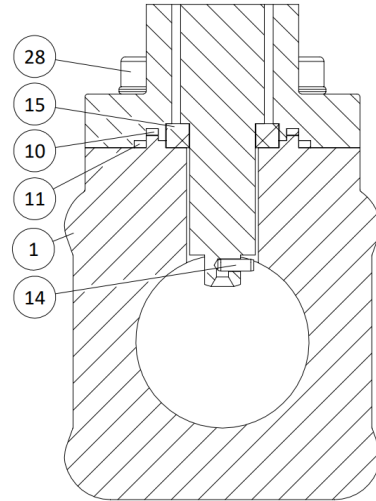

Figure 3 – Extension and body assembly

Table 4 – Extension bolting system torque [Nm]

DN		Md	Torque
FB	RB		
15	20	5	6.5
20	25	5	6.5
25	32	5	6.5
32	40	6	10
40	50	6	10
50	65	8	17.5
65	80	8	17.5
80	100	10	30
100	-	10	30
150	-	16	130

- Check if the stem (6) rotates freely with a uniform torque to check if any sealing has malfunctions;
- Place the fire safe packing (20), the washer (18), the stem seal (22) and the bearing (21) into the iso flange (4);
- Place the disc springs (23) and the stem nut (24) and tighten according to Table 5 –Fire safe packing system Torque [Nm]. Place the locking clip (25) into stem nut– Figure 4 – Fire safe packing assembly;
- Perform at least five complete cycles to accommodate the graphite packing. After these cycles it is supposed to observe a stabilization on the torque. If the torque increases without reaching a constant torque the stem or the packings may be damaged;

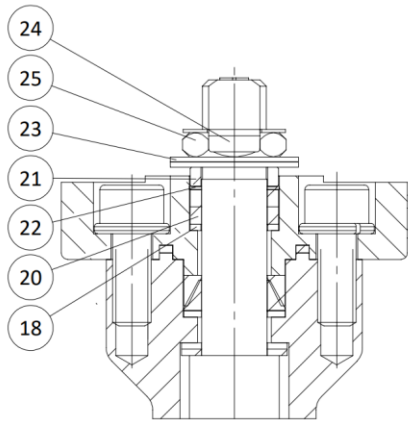

Figure 4 – Fire safe packing assembly.

Table 5 –Fire safe packing system Torque [Nm]

DN		Md	Torque
FB	RB		
15	20	10	5
20	25	12	10
25	32	12	10
32	40	16	20
40	50	16	20
50	65	20	25
65	80	24	30
80	100	24	30
100	-	30	40
150	-	42	55

10. Rotate the stem (6) to the **CLOSED** position, as indicated in the Figure 5 – Ball and internal seals assembly, and introduce the ball (5) into the body (1). Note that the ball/stem connection has only one position;
11. Rotate the lever for two cycles to check that the ball rotates freely and leave the valve in the **CLOSED** position;
12. Place the body seals (8/9) and the seats (7);
13. Place the end connections (2) and tighten the bolting (30) according to Table 6 – Body bolting system Torque [Nm];

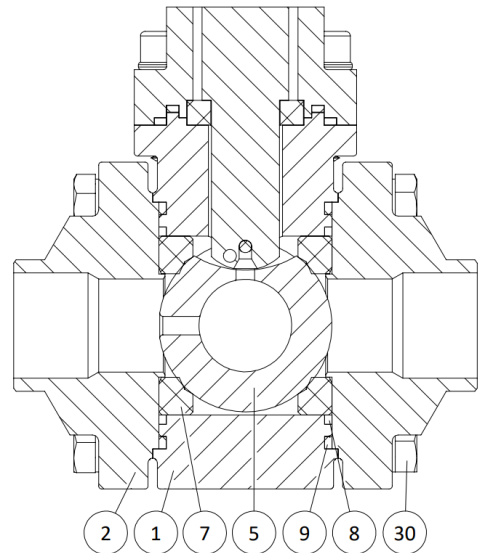

Figure 5 – Ball and internal seals assembly

Table 6 – Body bolting system Torque [Nm]

DN		Md	Torque
FB	RB		
15	20	8	20
20	25	10	40
25	32	10	40
32	40	12	70
40	50	14	110
50	65	14	110
65	80	14	110
80	100	14	110
100	-	14	110
150	-	16	150

14. Place the lever (26) and fix it with the handle fastener (27). This bolting system has no torque requirements as its only function is to hold the lever secured.

After reassembly the valve should be tested, if possible, in the line according to the chapter Operation.

iii. Disposal

Vinco ball valves are composed of various recyclable materials. Concerning environmental issues, it is advisable to dispose the materials according to the national regulations and deliver them to specialized recycling companies.

Be aware that the valve can still have some remaining residues of the working fluid. If the fluid is toxic, corrosive or other, inform the recycling company to prevent damage and dangerous disposal.

Cryogenic Range

CXF Series

3 pieces bolted – Floating
Antistatic
Cl 600/150
DN ½" (15) to 6" (150)



CCF Series

2 pieces bolted – Floating
Antistatic
Cl 150/300 | PN 16/40
DN ½" (15) to 6" (150)



Sanitary Range

RP / XP / LP / MP / QP



Industrial Range

CF / XF / SF / BF / HF
CTR / VTR



Hydrogen Range

CFH / XFH / SFH / BHF
GFH / HFH / CTH / VTH



Metallic Range

XFM / SFM / CFM / BFM
CTM / VTM

