

Series MV/F, MVM/F,
MVP/F, MVMP/F

Diaphragm Shut-off and Control Valves



Keep for future use!

This operating manual must be strictly observed before transport, installation, operation and maintenance

Subject to change without notice.

Reproduction is generally permitted with indication of the source.

© Richter Chemie-Technik GmbH

9510-050-en Revision 02 Edition 10/2009

List of Contents

| | | | |
|---|----------|--|-----------|
| List of Contents | 2 | 7 Operation | 9 |
| Relevant documents | 2 | 7.1 Initial commissioning..... | 9 |
| 1 Technical data | 3 | 7.2 Improper operation and their consequences 9 | |
| 1.1 Name plate, CE and body markings..... | 4 | 7.3 Shutdown | 9 |
| 1.2 Flow rates | 4 | 8 Malfunctions | 10 |
| 1.3 Tightening torques..... | 4 | 9 Maintenance | 11 |
| 1.4 Pressure-temperature diagram | 5 | 9.1 Replacing the diaphragm | 11 |
| 1.5 Required shut-off forces | 5 | 9.1.1 Dismantling diaphragm valve with handwheel | 11 |
| 2 Notes on safety | 6 | 9.1.2 Dismantling diaphragm valve with actuator | 11 |
| 2.1 Intended use..... | 6 | 9.1.3 Assembly | 11 |
| 2.2 For the customer / operator..... | 6 | 9.1.4 Assembly diaphragm valve with handwheel | 11 |
| 2.3 Improper operation | 6 | 9.1.5 Assembly diaphragm valve with actuator | 11 |
| 3 Safety notes for applications in potentially explosive areas based on the Directive 94/9/ EC (ATEX 95) | 7 | 9.1.6 Diaphragm valve with safety stuffing box | 11 |
| 3.1 Intended use..... | 7 | 10 Drawings | 12 |
| 4 Safety note for valves, certified to German Clean Air Act (TA Luft) | 8 | 10.1 Legend | 12 |
| 5 Transport, storage and disposal | 8 | 10.2 Options MV/F, MVM/F | 12 |
| 5.1 Storage..... | 8 | 10.3 Detail Diaphragm | 13 |
| 5.2 Return consignments | 8 | 10.4 Sectional drawing MV/F | 13 |
| 5.3 Disposal..... | 8 | 10.5 Sectional drawing MVM/F | 14 |
| 6 Installation | 9 | 10.6 Sectional drawing MVP/F..... | 15 |
| 6.1 Flange caps and gaskets | 9 | 10.7 Sectional drawing MVMP/F..... | 16 |
| 6.2 Direction of flow and installation position.... | 9 | 10.8 Options MVP/F, MVMP/F..... | 17 |
| 6.3 Grounding..... | 9 | 10.9 Dimensional drawing MV/F | 18 |
| 6.4 Test pressure | 9 | 10.10 Dimensional drawing MVM/F | 19 |
| | | 10.11 Dimensional drawing MVP/F | 20 |
| | | 10.12 Dimensional drawing MVMP/F | 21 |

Relevant documents

- ◆ Declaration of conformity PED 97/23/EC
- ◆ Form for Safety Information Concerning the Contamination QM 0912-16-2001_en
- ◆ For MVP/F and MVMP/F:
Operating manual for actuator

1 Technical data

Manufacturer :

Richter Chemie-Technik GmbH
 Otto-Schott-Str. 2
 D-47906 Kempen
 Telephone: +49 (0) 2152 146-0
 Fax: +49 (0) 2152 146-190
 E-Mail : richter-info@idexcorp.com
 Internet: <http://www.richter-ct.com>

Designation :

Diaphragm valve with PTFE diaphragm/EPDM diaphragm support

Diaphragm shut-off valve series

- MV/F** → Design DIN/ISO, hand-actuated
MVM/F → Design MSS SP-88, hand-actuated

Diaphragm control valve series

- MVP/F** → Remote actuation by pneumatic actuators to DIN /ISO 5211
- of column-style/bracket-style design
 - of compact design
- or by electric actuators

- MVMP/F** → Remote actuation by pneumatic actuators to DIN /ISO 5211
- of column-style/bracket-style design
 - of compact design
- or by electric actuators

Certified to German Clean Air Act (TA Luft)

Strength and tightness (P10, P11) of the pressure-bearing body tested to DIN EN 12266-1.

Gas-tight (P12) in the seat to DIN EN 12266-1, leak rate A

Face to face, optionally:

- DIN EN 558-1 basic series 1, ISO 5752 series 1 with flanges DIN EN 1092-2, Form B (ISO 7005-2 Type B) PN 16 or flanges drilled to ASME (ANSI) B16.5 Class 150
- MSS SP-88 with flanges drilled to ASME B16.5 Class 150

Materials :

Body material: Ductile cast iron EN-JS 1049 to DIN EN 1563 (0.7043 DIN 1693) or ASTM A395

Lining material: PFA/PTFE .../F
 On request: antistatic .../F-L
 highly permeation-resistant .../F-P

Diaphragm: TFM-PTFE with EPDM diaphragm support (on request antistatic diaphragm of PTFE)

Bonnet, handwheel, stem (valve stem) and compressor: Stainless steel

Temperature range : -30°C to 150° C

see pressure-temperature diagram in Section 1.4.

Test pressure : PN 16 to DN 50

PN 10 to DN 80 and larger

Operating pressure and vacuum see pressure-temperature diagram in Section 1.4.

Diaphragm valve sizes :

DIN/ISO: DN 15, 20, 25, 40, 50, 80, 100, 150
 MSS SP-88 1", 1½", 2", 3", 4", 6"

Installation position : any

See Section 6.2.

Dimensions and parts :

See sectional drawing Section 10.

Weights :

| Nominal Size | | Manually operated (ca. in kg) | | without actuator (ca. in kg) | |
|--------------|-----|-------------------------------|------|------------------------------|------|
| ISO | MSS | ISO | MSS | ISO | MSS |
| 15 | ½" | 4,0 | --- | 4,2 | --- |
| 20 | ¾" | 4,0 | --- | 4,2 | --- |
| 25 | 1" | 4,6 | 4,5 | 4,8 | 4,7 |
| 40 | 1½" | 8,9 | 7,9 | 9,1 | 8,9 |
| 50 | 2" | 11,6 | 11,0 | 12,0 | 11,4 |
| 80 | 3" | 23,7 | 23,0 | 21,3 | 20,6 |
| 100 | 4" | 33,5 | 30,7 | 29,7 | 26,9 |
| 150 | 6" | 64,6 | 59,5 | 56,2 | 51,1 |

Weight for actuator see manufacturer of actuators

Wear parts:

- ◆ Diaphragm / support diaphragm,

Option safety packing:

- ◆ packing rings

Options :

- ◆ Travel stop for MVP/F, MVMP/F
- ◆ Safety packing for use with hazardous or environmentally critical media, adjustable from outside by hand.
- ◆ Optional with monitory connection
- ◆ Secondary O-ring made of FKM protects interior against corrosive atmosphere, splash water, cleaning agents or dust.

1.1 Name plate, CE and body markings

The stainless steel name plate is undetachably riveted to the body.

If the operator attaches his identification, it must be ensured that the valve matches the application in question.

Example of name plate with CE marking:

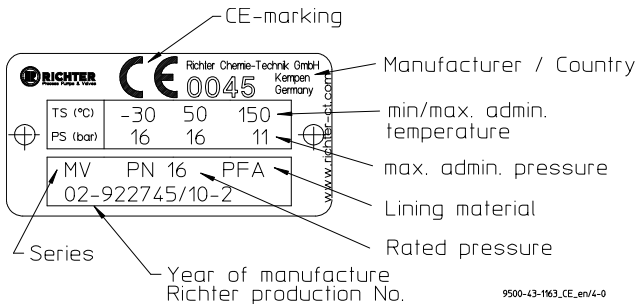

Example : Second name plate

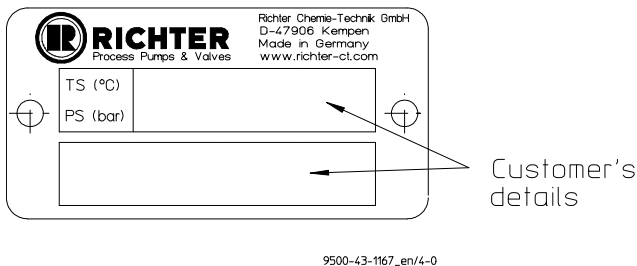

No CE marking is permissible for the sizes 15, 20 and 25; the name plate therefore has no CE marking.

Body marking :

The following are visible on the body according to DIN EN 19 and AD 2000 A4:

- ◆ Nominal size
- ◆ Rated pressure
- ◆ Body material
- ◆ Manufacturer's identification
- ◆ Melt number/Foundry identification
- ◆ Foundry date

1.2 Flow rates

| Nominal size | | kv100 [m ³ /h] |
|--------------|--------|------------------------------|
| [mm] | [inch] | |
| 15 | 1/2" | 10 |
| 20 | 3/4" | 10 |
| 25 | 1" | 15 |
| 40 | 1 1/2" | 37 |
| 50 | 2" | 65 |
| 80 | 3" | 134 |
| 100 | 4" | 200 |
| 150 | 6" | 452 |

1.3 Tightening torques

All screws greased, tighten in diametrically opposite sequence!

The tightening torques for pipe screws and body screws mentioned must not be exceeded. For an exception, see Section 8 flange connection valve / pipe is leaking.

The following tightening torques are recommended:

Pipe screws, flanges to ISO/DIN

| Flanges Nom. size [mm] | Screws [ISO/DIN] | Tightening torque | |
|------------------------------|---------------------|-------------------|----------|
| | | [Nm] | [in-lbs] |
| 15 | 4 x M12 | 6 | 55 |
| 20 | 4 x M12 | 8 | 70 |
| 25 | 4 x M12 | 10 | 90 |
| 40 | 4 x M16 | 20 | 180 |
| 50 | 4 x M16 | 26 | 230 |
| 80 | 8 x M16 | 25 | 220 |
| 100 | 8 x M16 | 35 | 310 |
| 150 | 8 x M20 | 65 | 575 |

Pipe screws, flanges to ASME Class 150 or flanges to ISO/DIN, drilled to ASME Class 150

| Flanges Nom. size | | Screws [ASME] | Tightening torque | |
|----------------------|--------|------------------|-------------------|------|
| [mm] | [inch] | | [in-lbs] | [Nm] |
| 15 | 1/2" | 4 x 1/2" | 45 | 5 |
| 20 | 3/4" | 4 x 1/2" | 55 | 6 |
| 25 | 1" | 4 x 1/2" | 70 | 8 |
| 40 | 1 1/2" | 4 x 5/8" | 135 | 15 |
| 50 | 2" | 4 x 5/8" | 220 | 25 |
| 80 | 3" | 4 x 5/8" | 400 | 45 |
| 100 | 4" | 8 x 5/8" | 310 | 35 |
| 150 | 6" | 8 x 3/4" | 710 | 80 |

Body screws

| Nominal size | Screws | | Tightening torque | | |
|--------------|--------|--------|-------------------|------|------------|
| | [mm] | [inch] | [ISO/DIN] | [Nm] | [inch-lbs] |
| 15 | 1/2" | | 4 x M8 | 12 | 106 |
| 20 | 3/4" | | 4 x M8 | 12 | 106 |
| 25 | 1" | | 4 x M8 | 12 | 106 |
| 40 | 1 1/2" | | 4 x M10 | 25 | 221 |
| 50 | 2" | | 4 x M10 | 31 | 274 |
| 80 | 3" | | 4 x M16 | 80 | 708 |
| 100 | 4" | | 8 x M12 | 55 | 487 |
| 150 | 6" | | 10 x M16 | 135 | 1195 |

1.4 Pressure-temperature diagram

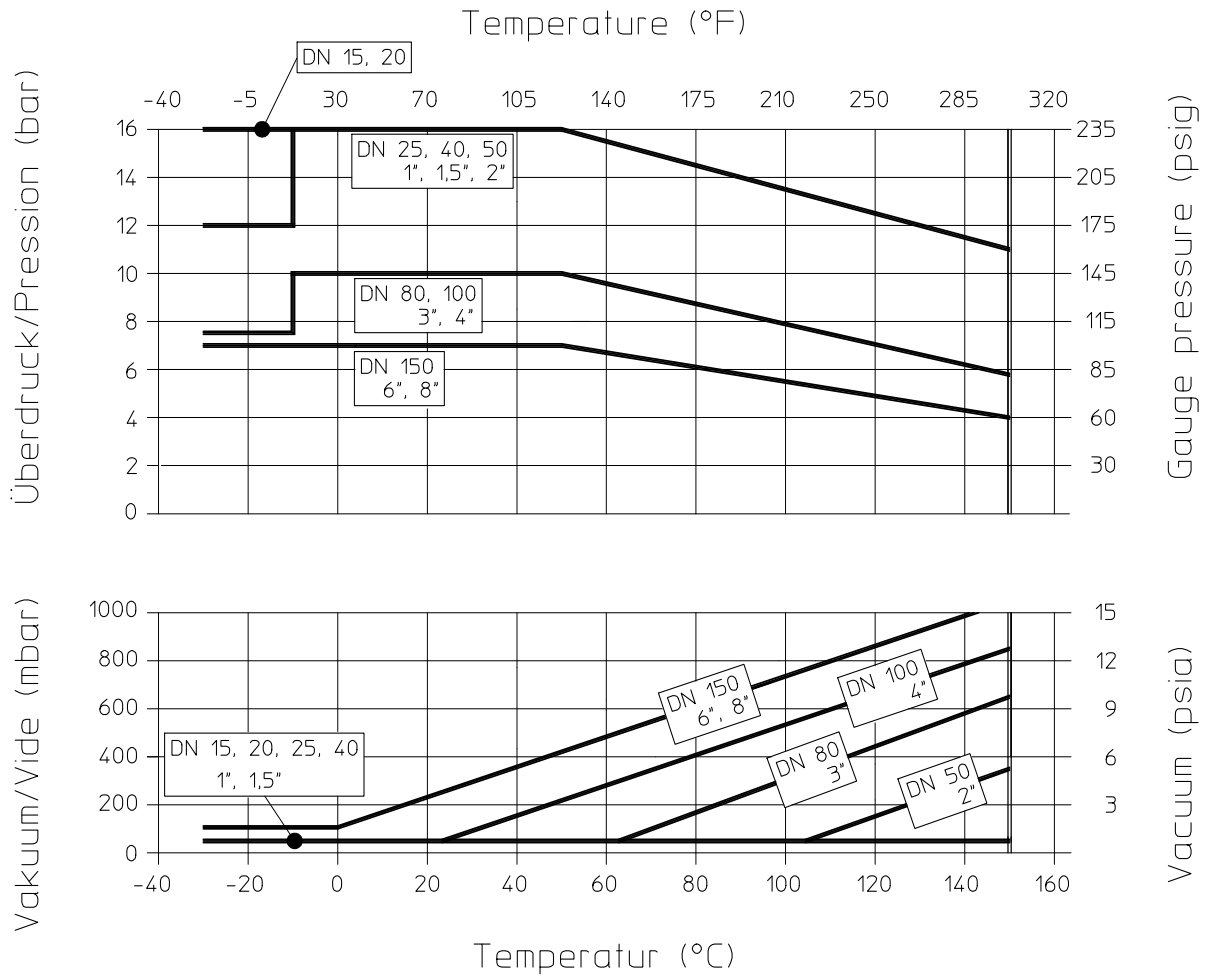

9500-43-1162/4-0



When used in the minus temperature range, the regulations applicable in the country in question must be observed.

1.5 Required shut-off forces

Forces apply to PFA/PTFE-lined body and PTFE diaphragm. Other materials for linings and diaphragms require different forces.

| bar | p1 is stated at p2 = 0 bar (overpressure) | | | | | | | | | | |
|-----|---|------|-------|-------|-------|-------|-------|-------|------|-------|------|
| | 1 | 2 | 3 | 4 | 5 | 6 | 8 | 10 | 12 | 14 | 16 |
| psi | 14,5 | 29 | 43,5 | 58 | 72,5 | 87 | 116 | 145 | 174 | 203 | 232 |
| DN | N | N | N | N | N | N | N | N | N | N | N |
| 15 | 976 | 1040 | 1105 | 1181 | 1246 | 1311 | 1441 | 1582 | 1712 | 1842 | 1972 |
| 20 | 1370 | 1473 | 1572 | 1676 | 1779 | 1880 | 2085 | 2287 | 2494 | 2697 | 2904 |
| 25 | 1370 | 1473 | 1572 | 1676 | 1779 | 1880 | 2085 | 2287 | 2494 | 2697 | 2904 |
| 40 | 1598 | 1863 | 2133 | 2398 | 2663 | 2931 | 3463 | 3997 | 4529 | 5073* | 5616 |
| 50 | 1598 | 1863 | 2133 | 2398 | 2663 | 2931 | 3463 | 3997 | 4529 | 5073* | 5616 |
| 80 | 2904 | 3645 | 4383 | 5120 | 5861 | 6598 | 8077 | 9556 | | | |
| 100 | 5019 | 6105 | 7190 | 8273 | 9360 | 10446 | 12616 | 14786 | | | |
| 150 | 6665 | 8744 | 10825 | 12907 | 14985 | 17067 | | | | | |

2 Notes on safety

This operating manual contains fundamental information which is to be observed during installation, operation and maintenance.

It must therefore be read before installation and commissioning!

For valves which are used in potentially explosive areas, see **Section 3**.

Installation, operation and maintenance are to be performed by qualified staff.

The area of responsibility, authority and supervision of the staff must be regulated by the customer.



General hazard symbol!

People may be put at risk.



Safety symbol! The valve and its function may be put at risk if this safety symbol is not observed.

It is imperative to observe warnings and signs attached directly to the valve and they are to be kept fully legible.

Non-observance of the notes on safety may result in the loss of any and all claims for damages.

For example, non-observance may involve the following hazards:

- ◆ Failure of important functions of the valve/plant.
- ◆ Risk to people from electric, mechanical and chemical effects.
- ◆ Risk to the environment through leaks of hazardous substances.

2.1 Intended use

Richter diaphragm valves are pressure containing components in accordance with the Pressure Equipment Directive (PED) for the passage and shut-off of fluids at a specified differential pressure.

The valves are suitable for vapours, gases and non-boiling liquids of group 1 according to the PED and have a corrosion-resistant plastic lining.

They are used as shut-off, control and throttling valves for corrosive, pure and high-purity liquids, gases and vapours in chemical, pharmaceutical, food and industrial processes.

They are hermetically tight.

The wetted materials are FDA-compliant.

Richter diaphragm valves are soft-sealing and gas-tight.

Solids can lead to increased wear, leaks, damage to sealing surfaces or to a reduction in the service life of the valve.

If the valve is intended for operating data other than those intended, the customer must carefully examine whether the design of the valve, accessories and materials are suitable for the new application (consult the manufacturer).

2.2 For the customer / operator

If a valve is used, the operator must ensure that

- ◆ actuators which are retrofitted are adapted to suit the valve
- ◆ hot or cold valve parts are protected by the customer against being touched
- ◆ the valve has been properly installed in the pipe system
- ◆ the usual flow rates are not exceeded in continuous operation.

This is not the manufacturer's responsibility

Loads caused by earthquakes were not allowed for in the design.

Fire protection to DIN EN ISO 10497 is not possible (plastic lining and plastic components).

Diaphragm valves which are used as end valves must be sealed with a blind flange at the free connection end and appropriately secured against unauthorised activation.



2.3 Improper operation

The operational reliability of the valve supplied is only guaranteed if it is used properly in accordance with **Section 2.1** of this operating manual.



The operation limits specified on the identification plate and in the pressure-temperature diagram must under no circumstances be exceeded.

3 Safety notes for applications in potentially explosive areas based on the Directive 94/9/ EC (ATEX 95)

The valves are intended for use in a potentially explosive area and are therefore subject to the conformity assessment procedure of the directive 94/9/EC (ATEX).

As part of this conformity assessment, an ignition hazard analysis to EN 13463-1 to satisfy the fundamental safety and health requirements was conducted with the following result:

- ◆ **The valves do not have any ignition source of their own and can be operated both manually as well as mechanically/electrically.**
- ◆ **The valves are not covered by the scope of application of the ATEX directive and therefore do not need to be identified accordingly.**
- ◆ **The valves may be used in a potentially explosive area.**

Supplementary notes:

- ◆ **Electric/mechanical actuators must be subjected to their own conformity assessment to ATEX.**

It is imperative to observe the individual points of intended use for application in a potentially explosive area.

3.1 Intended use

Improper operation, even for brief periods, may result in serious damage to the unit.

In connection with explosion protection, potential sources of ignition (overheating, electrostatic and induced charges, mechanical and electric sparks) may result from these improper operation; their occurrence can only be prevented by adhering to the intended use.

Furthermore, reference is made in this connection to the Directive 95/C332/06 (ATEX 118a) which contains the minimum regulations for improving the occupational health and safety of the workers who may be at risk from an explosive atmosphere.

A difference is made between two cases for the use of chargeable liquids (conductivity $<10^{-8}$ S/m):

1. Chargeable liquid and non-conductive lining

Charges can occur on the lining surface. As a result, this can produce discharges inside the valve. However, these discharges cannot cause ignitions if the valve is completely filled with medium.

If the valve is not completely filled with medium, e.g. during evacuation and filling, the formation of an explosive atmosphere must be prevented, e.g. by superimposing a layer of nitrogen.

It is recommended to wait 1 hour before removing the valve from the plant in order to permit the elimination of static peak charges.

This means that, to safely prevent ignitions, the valve must be completely filled with medium at all times or else a potentially explosive atmosphere must be excluded by superimposing a layer of inert gas.

2. Chargeable liquid and conductive lining

No hazardous charges can occur as charges are discharged direct via the lining and shell (surface resistance $<10^9$ Ohm, leakage resistance $<10^6$ Ohm).

Static discharges of non-conductive linings are only produced through the interaction with a non-conductive medium and are therefore the responsibility of the plant operator.

Static discharges are not sources of ignition which stem from the valves themselves!

- The temperature of the medium must not exceed the temperature of the corresponding temperature class or the maximum admissible medium temperature as per the operating manual.
- If the valve is heated (e.g. heating jacket), it must be ensured that the temperature classes prescribed in the Annex are observed.
- To achieve safe and reliable operation, it must be ensured in inspections at regular intervals that the unit is properly serviced and kept in technically perfect order.
- Increased wear to the valve can be expected with the conveyance of liquids containing abrasive constituents. The inspection intervals are to be reduced compared with the usual times.
- Actuators and electric peripherals, such as temperature, pressure and flow sensors etc., must comply with the valid safety requirements and explosion protection provisions.
- The valve must be grounded.
This can be achieved in the simplest way via the pipe screws using tooth lock washers. Otherwise grounding must be ensured by other action, e.g. cable bridges.
- Attachments such as actuators, position controllers, limit switches etc. must satisfy the relevant safety regulations as regards explosion protection and, if required, be designed in compliance with ATEX.
- Special attention must be paid to the appropriate safety and explosion protection notes in the respective operating manuals.
- Plastic-lined valves must not be operated with carbon disulphide.

4 Safety note for valves, certified to German Clean Air Act (TA Luft)

On request, this valve can be supplied compliant with the German Clean Air Code.

Certificate / Manufacturer Declaration Validity is dependent on the operating instructions being read and observed.

In particular, servicing must be conducted at regular intervals, and the bolted connections relevant for tightness must be inspected and retightened if necessary.

5 Transport, storage and disposal



It is imperative, for all transport work, to observe generally accepted engineering practice and the accident prevention regulations.



The valve is supplied with flange caps. Do not remove them until just before installation. They protect the plastic surfaces against dirt and mechanical damage.

Handle the goods being transported with care. During transport the valve must be protected against impacts and collisions.

Directly after receipt of the goods, the consignment must be checked for completeness and any in-transit damage.

Do not damage the external epoxy coating.

5.1 Storage

If the valve is not installed immediately after delivery, it must be put into proper storage.

It should be stored in a dry, vibration-free and well-ventilated room at as constant a temperature as possible.

Elastomers are to be protected against UV light.

In general, a storage period of 10 years should not be exceeded.

5.2 Return consignments



Valves which have conveyed aggressive or toxic media must be well rinsed and cleaned before being returned to the manufacturer's works.

It is **imperative** to enclose a **safety information sheet / general safety certificate** on the field of application with the return consignment.

Pre-printed forms are enclosed with the installation and operating manual.

Safety precautions and decontamination measures are to be mentioned.

5.3 Disposal

Parts of the valve may be contaminated with medium which is detrimental to health and the environment and therefore cleaning is not sufficient.



Risk of personal injury or damage to the environment due to the medium!

- ◆ Wear protective clothing when work is performed on the valve.
- ◆ Prior to the disposal of the valve:
 - Collect any medium, etc. which has escaped and dispose of it in accordance with the local regulations.
 - Neutralise any medium residues in the valve.
- ◆ Separate valve materials (plastics, metals, etc.) and dispose of them in accordance with the local regulations.

6 Installation

- ◆ Examine valve for in-transit damage, damaged diaphragm valves may not be installed.
- ◆ Before installation the valve and the connecting pipe must be carefully cleaned to remove any dirt, especially hard foreign matter.
- ◆ During installation, pay attention to the correct tightening torque, aligned pipes and tension-free assembly.



Ensure that a remotely actuated actuator cannot be accidentally switched on.

6.1 Flange caps and gaskets

- ◆ Leave protective caps on the flanges until just prior to installation.

Where there is a particularly high risk of damage to the plastic sealing surfaces, e.g. if the mating flanges are made of metal are glass-lined, PTFE-lined gaskets with a metal inlay should be used. These gaskets are available as special accessories in the Richter range.

6.2 Direction of flow and installation position

Installation is independent of the direction of flow. Any installation position can be chosen.

6.3 Grounding

The valve must be grounded. The simplest solution is to use tooth lock washers which are placed under one pipe bolt of each flange.

At the customer's request a setscrew M6 with a hex. nut and washer will be provided at each flange as an additional grounding connection.

Otherwise grounding must be ensured by different measures e.g. a cable link.

6.4 Test pressure

The test pressure PT of an open valve must not exceed the value of $1.5 \times PN/PS$ as per the identification of the valve.

7 Operation

7.1 Initial commissioning

Normally, the valves have been tested for leaks with air or water. Prior to initial operation check body bolting. For torques see [Section 1.3](#).



Unless otherwise agreed, there could be residual amounts of water in the flow section of the valve; this could result in a possible reaction with the medium.

To prevent leaks, all connection screws should be retightened after the initial loading of the valve with operating pressure and operating temperature.

For torques see [Section 1.3](#).

7.2 Improper operation and their consequences

- ◆ When operating in the range of below-zero temperatures, the national regulations are to be observed.
- ◆ Operation with solids leads to increased wear.
- ◆ Operating during cavitation leads to increased wear.
- ◆ Non-observance of the pressure-temperature diagram can lead to damage.

- ◆ Do not subject the handwheel to heavy loads; the handwheel or diaphragm valve may be damaged.
- ◆ Do only use a handwheel without lever extension as otherwise there is a risk of damage.
- ◆ If no monitoring is provided by the warning connection, do not tighten safety stuffing box. Otherwise any leak cannot be seen.

7.3 Shutdown

The local regulations are to be observed when dismantling the valve.

Prior to undoing the flange connection ensure, that the plant is depressurised and emptied.



Prior to starting any repair work, the valve is to be thoroughly cleaned. Even if the valve has been properly emptied and rinsed, residual medium may still be found in the valve.

After dismantling, immediately protect the valve flanges against mechanical damage with flange caps. See also [Section 6.1](#).



Ensure that a remotely actuated actuator cannot be accidentally switched on.

8 Malfunctions

- ◆ Flange connection valve/pipe is leaking
Retighten the flange screws to a tightening torque according to **Section 1.3**. If this does not remedy the leak, the recommended torques may be exceeded by 10%.
If this also fails to stop the leak, dismantle and inspect the valve.
- ◆ Flange connection body / bonnet is leaking
Retighten the body screws to a tightening torque according to **Section 1.3**. If this does not remedy the leak, the recommended torques may be exceeded by 10%.
- ◆ Safety stuffing box (option) leaks
Tighten packing nut until the leak has been eliminated.
Then dismantle the valve as quickly as possible and repair.
- ◆ Diaphragm valve does not switch
Is the actuator being supplied with power?
Is a directional control valve connected correctly?
Is there any foreign matter in the diaphragm valve?
Leak between stem/bonnet and handwheel
Diaphragm is defective. See **Section 9.1**.
In the case of valves which were opened, the diaphragm must always be replaced with a new one.

9 Maintenance

- ◆ All repair work is to be performed by qualified personnel using the appropriate tools.
- ◆ For the arrangement, designation and item numbers of all parts of the valve, see Section 10.
- ◆ Spare parts are to be ordered with all the details in acc. with the valve identification.
- ◆ Only original spare parts may be installed.
- ◆ To prevent leaks, a regular check of the connection screws should be made in line with the operating requirements.
For torques see Section 1.3.

9.1 Replacing the diaphragm

9.1.1 Dismantling diaphragm valve with handwheel



The plant must be depressurised and drained! The valve can remain installed during the maintenance work.

- Undo hex. nuts **920/1** of the bonnet **112** and remove. The handwheel can remain installed for replacing the diaphragm.
- Remove bonnet **112**.
- Unscrew stem **855** off the bonnet.
- Unscrew the compressor **211** out of the diaphragm / diaphragm support **212** out of the tube nut **569**.
- Remove diaphragm / diaphragm support **212**.

9.1.2 Dismantling diaphragm valve with actuator

Compact actuator: Observe separate instructions.

Dismantling column-style/bracket-style actuator:

- Remove actuator **850** and coupling **804**.
- Remove bracket **510** or yoke **516** with protective bellows **687/1** and travel stop.
- The entire actuator with bonnet can also be removed to replace the diaphragm.
- For further dismantling, proceed as described in Section 9.1.1.

9.1.3 Assembly

- Prior to assembly all parts are to be cleaned and the plastic-lined components be checked for damage.
- The entire valve is always assembled in the open position.

9.1.4 Assembly diaphragm valve with handwheel

- Screw diaphragm/diaphragm support **212** into the tube nut **569** in the compressor **211** up to the stop and turn into the correct position.
- Turn the stem **855** into the bonnet **112**.
- Connect compressor **211** with stem **855**. Push compressor guide onto the stem from the side.
- Screw stem **855** in the open position right up to the travel stop.
- Mount bonnet **112** onto the body and bolt together. For tightening torques, see Section 1.3.
- Leak test with handwheel. Turn nut until up against the bonnet.

9.1.5 Assembly diaphragm valve with actuator

Compact actuator: Observe separate instructions.

Dismantling column-style/bracket-style actuator:

- For assembly of bracket **510** or yoke **516**, see drawing in Section 10.
- Option
Mount travel stop **508** with protective bellows **687/1**.
- Mount coupling **804** and actuator **850**. Observe securing position, see operating instructions for the actuator.
- For further assembly, proceed as described in Section 9.1.4.

9.1.6 Diaphragm valve with safety stuffing box

A modified bonnet is used when installing a safety stuffing box.

- Insert 2 packing rings **402/1** offset against each other.
- Insert thrust ring **405/1**.
- Screw on packing nut **404**. Only tighten further in the event of a leak.

In order to ensure leak monitoring, Richter recommends the combination of the safety stuffing box with a warning connection.

If only the safety stuffing box is present, do not tighten it so that any leak becomes visible. Otherwise the valve may be destroyed by an unnoticed internal leak.

10 Drawings

10.1 Legend

| | | | |
|--------------|-----------------------------|-------------------------------------|----------------------|
| 100 | body | 855 | stem |
| 112 | bonnet | 901/1 | hex. screw |
| 210 | handwheel | 902/x | stud screw |
| 211 | compressor | 920/x | hex. nut |
| 212 | diaphragm/diaphragm support | Option safety stuffing box | |
| 300 | plain bearing | 402/1 | packing ring |
| 302/x | guide ring | 404 | packing nut |
| 400/1 | o-Ring (option) | 405 | thrust ring |
| 510 | bracket | Option monitoring connection | |
| 516 | yoke | 938/1 | hex. head screw plug |
| 517 | scraper ring | Option travel stop | |
| 523 | stroke index | 508 | travel stop |
| 550 | disc | 687/1 | protective bellows |
| 556 | bearing disc | includes: | |
| 569 | tube nut | 509/1 | groove nut |
| 800 | valve stem | 954/1 | snap ring |
| 804 | coupling | 937/1 | clip |
| 850 | actuator | 920/3/4 | hex, nut, thin |

10.2 Options MV/F, MVM/F

Option safety stuffing box

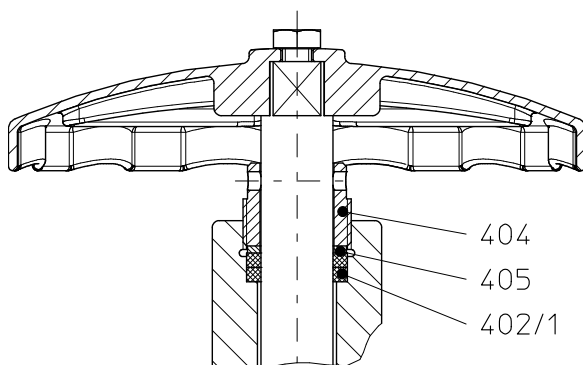

Option monitoring connection

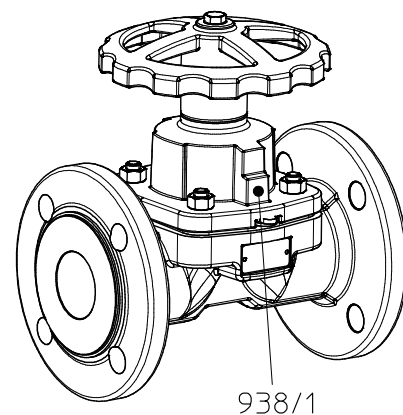

9500-43-1164_en/4-0

10.3 Detail Diaphragm

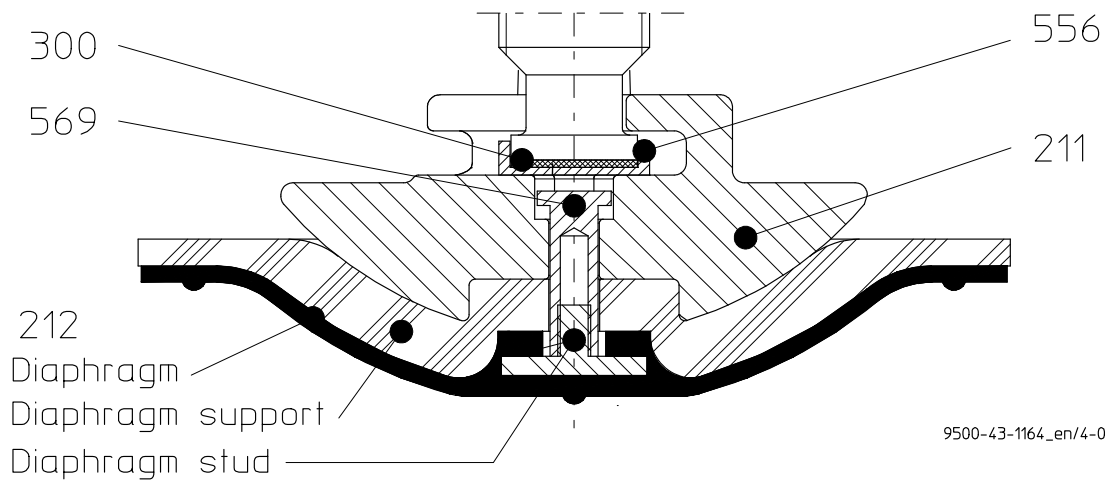

10.4 Sectional drawing MV/F

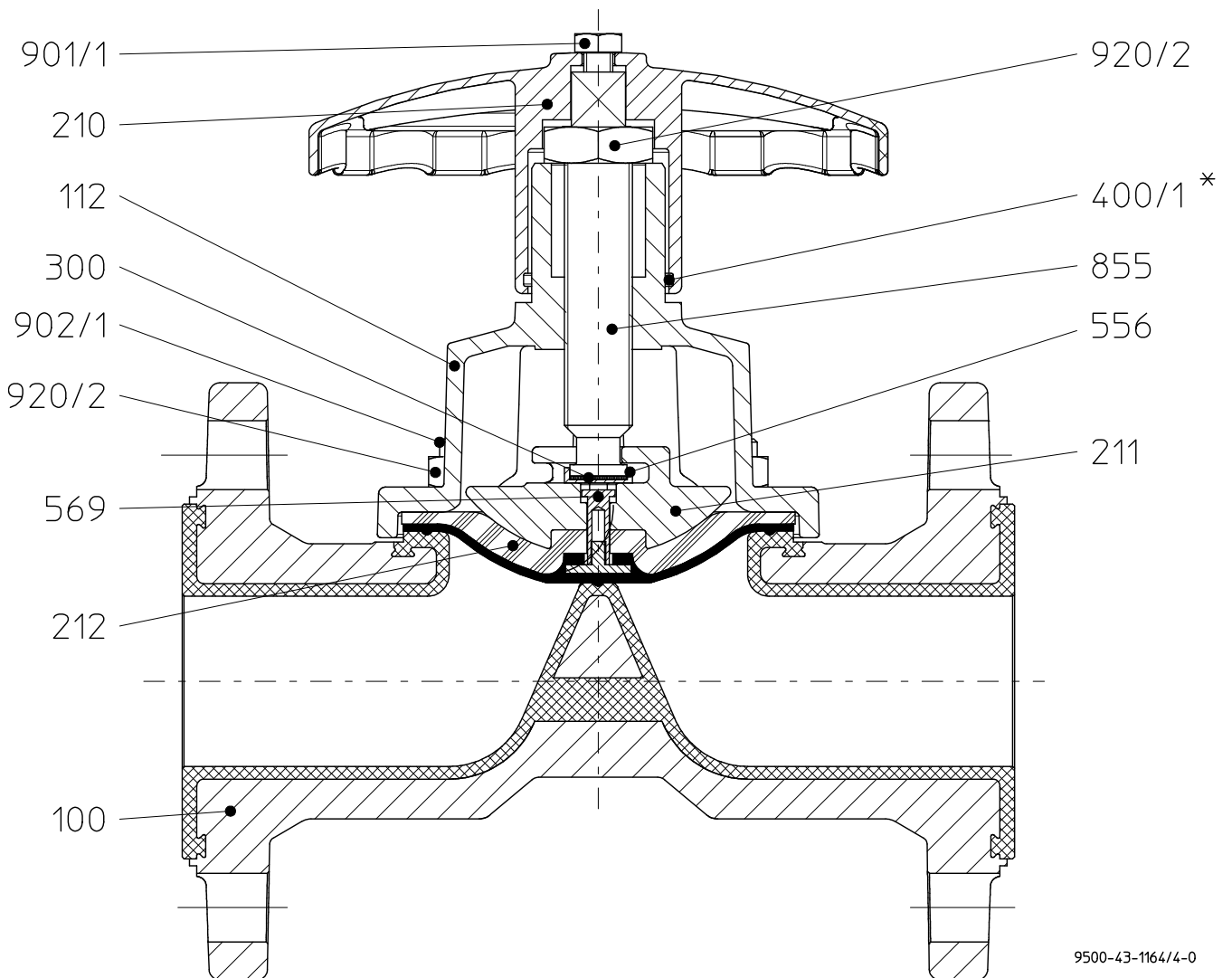

10.5 Sectional drawing MVM/F

Holes of the flange screws view displaced by 45°

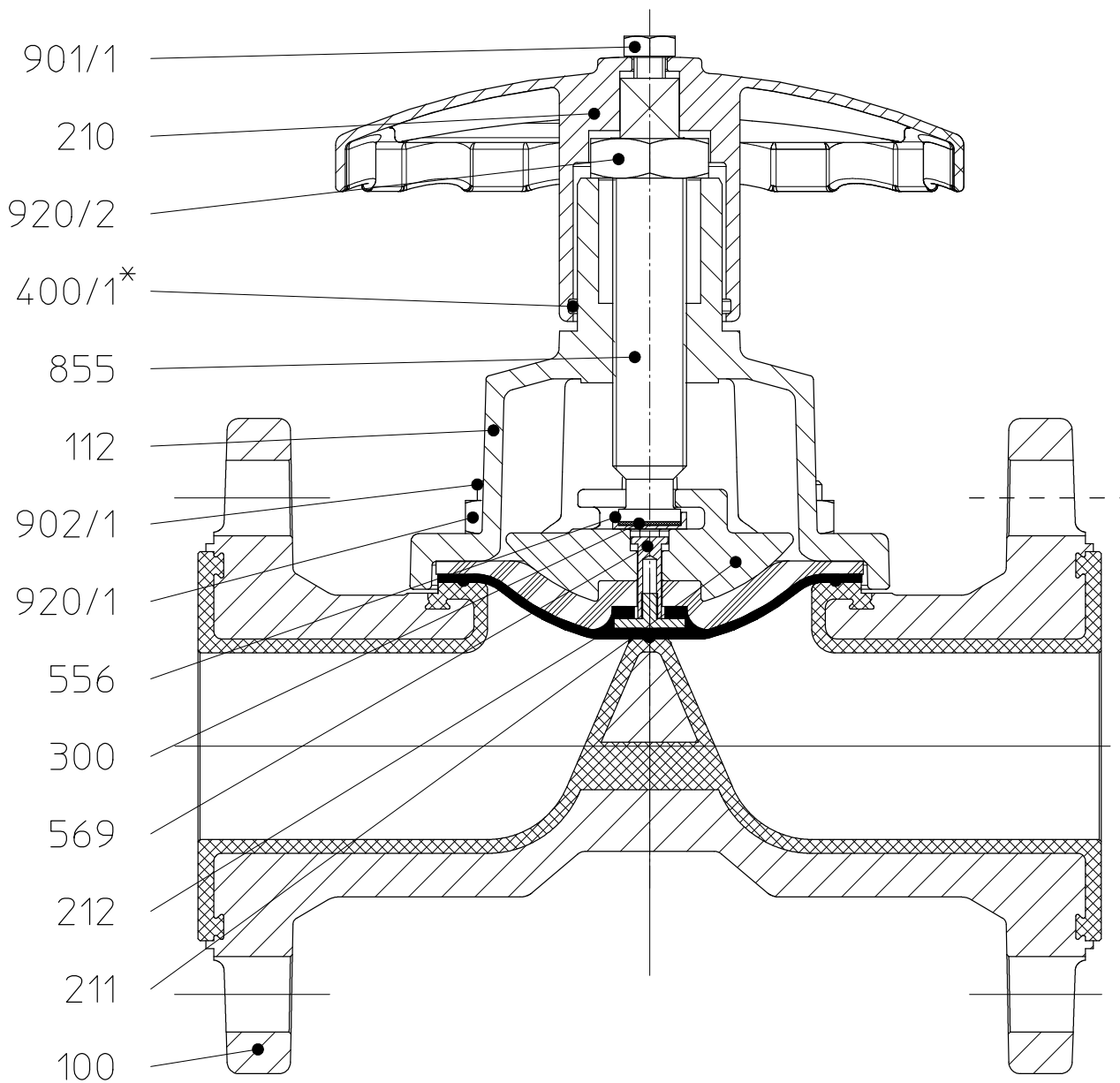

Holes of the flange screws view displaced by 45°

10.6 Sectional drawing MVP/F

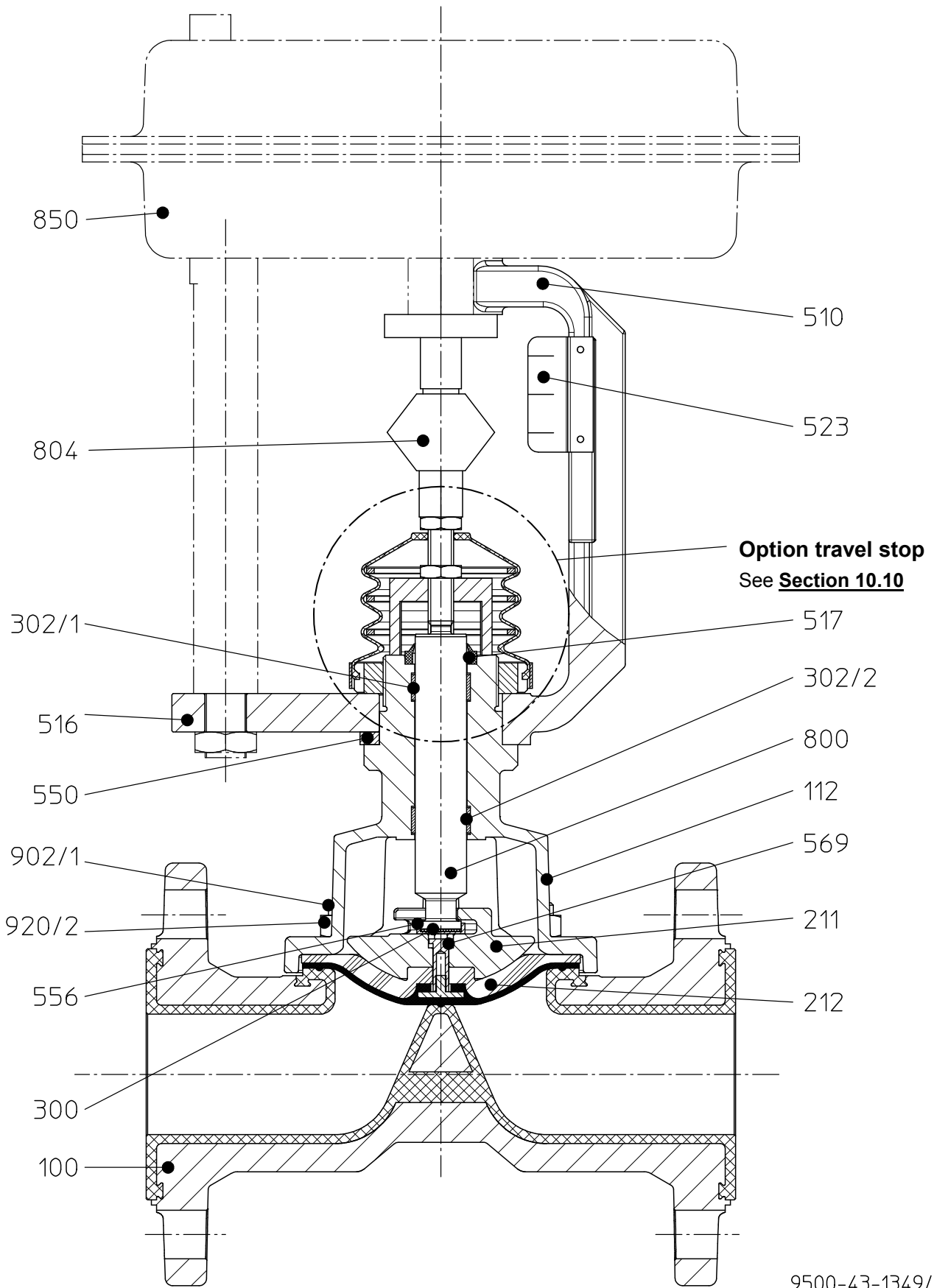

Holes of the flange screws view displaced by 45°

9500-43-1349/4-0

10.7 Sectional drawing MVMP/F

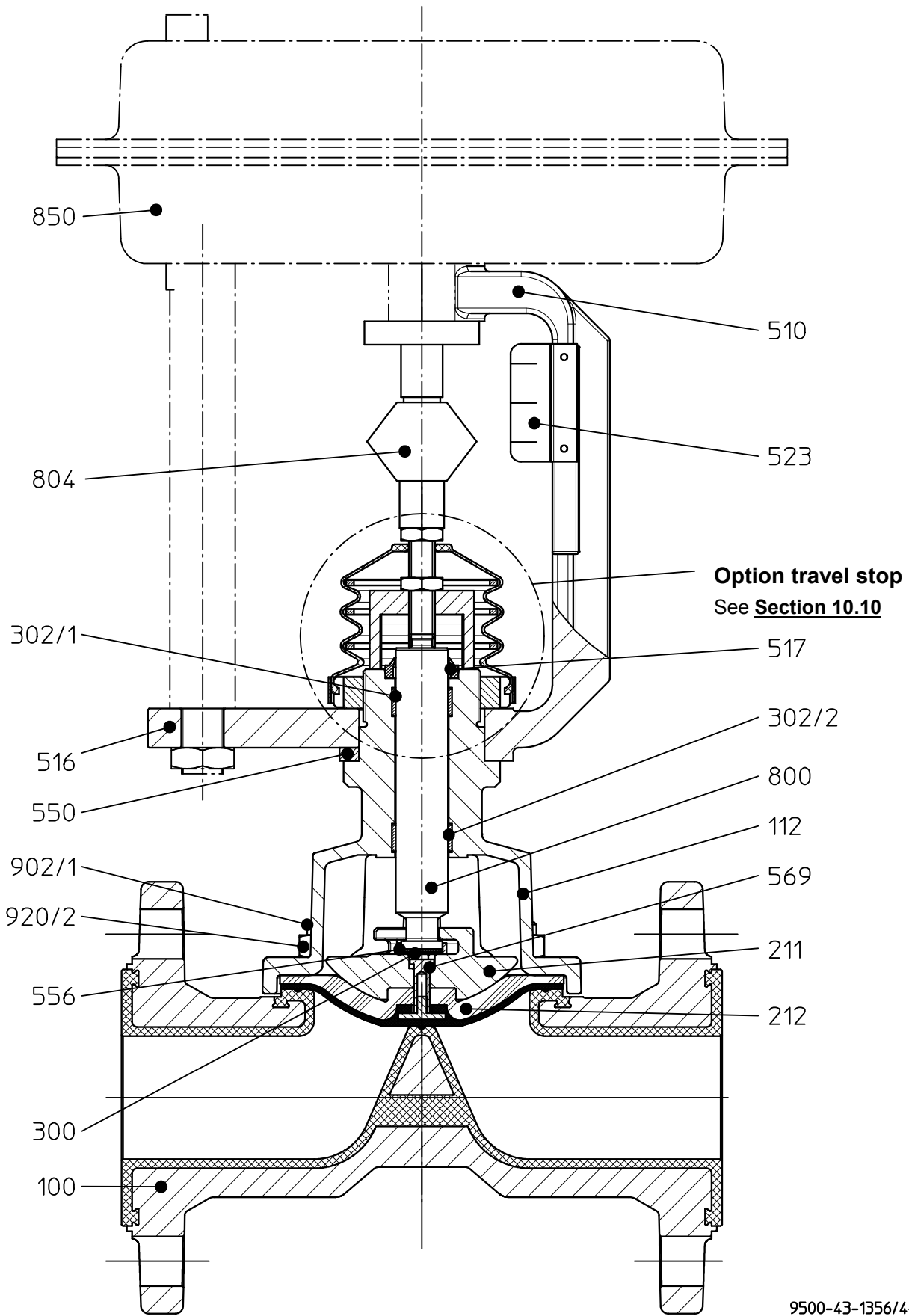

Holes of the flange screws view displaced by 45°

10.8 Options MVP/F, MVMP/F

Option safety stuffing box

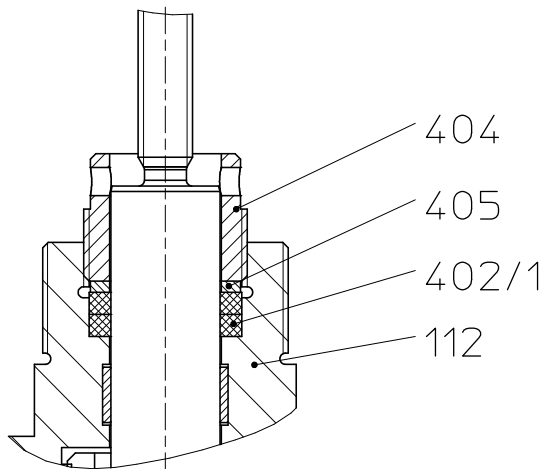

Option travel stop

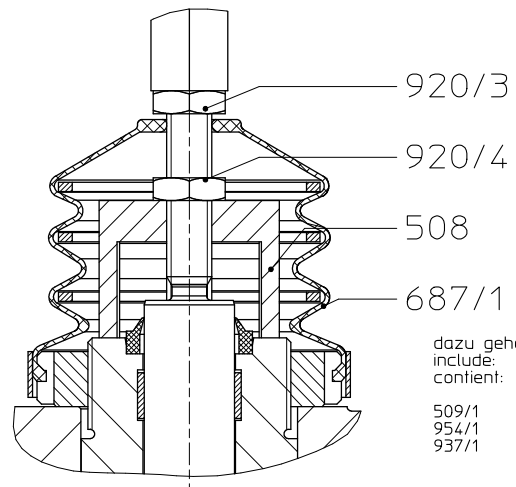

dazu gehört:
include:
content:
509/1
954/1
937/1

Option monitoring connection

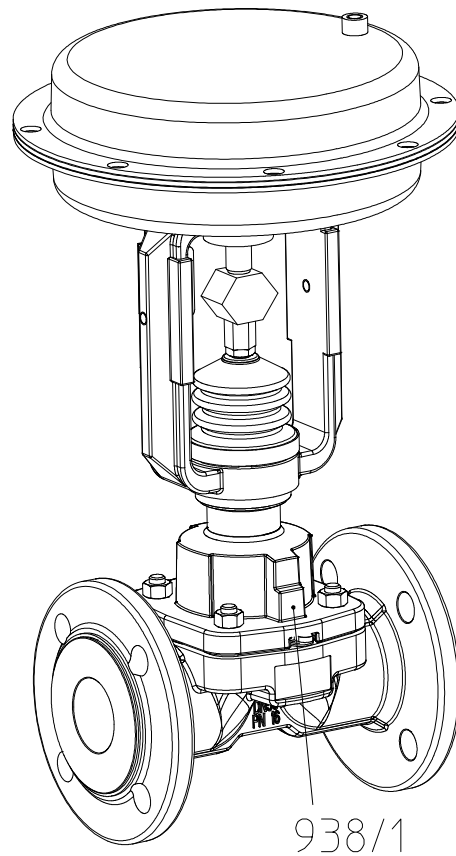

10.9 Dimensional drawing MV/F

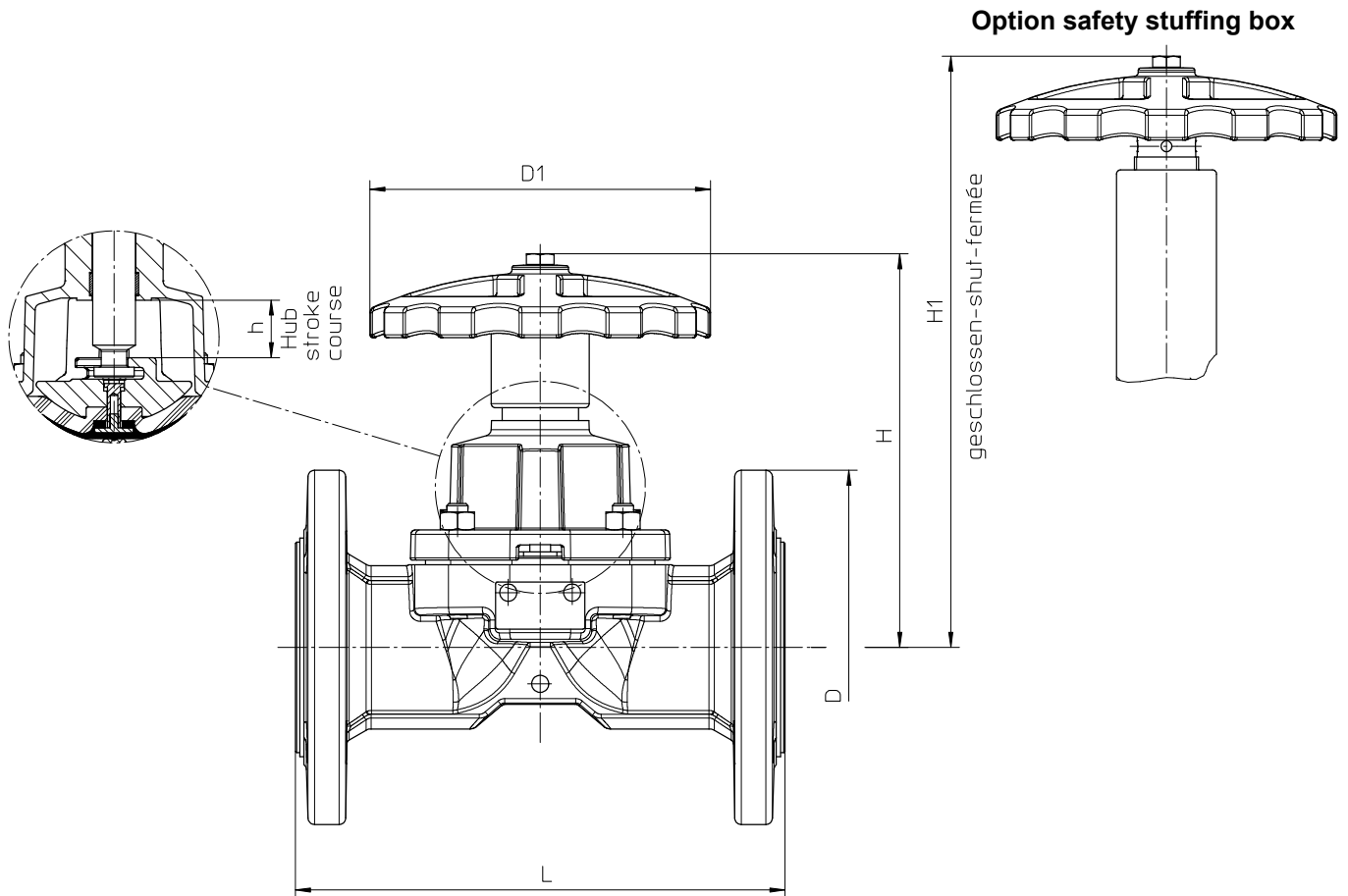

| DN | L [mm] [inch] | D [mm] [inch] | D1 [mm] [inch] | H [mm] [inch] | H1 [mm] [inch] | h (stroke) [mm] [inch] | Weight [kg] [lb] |
|-----|---------------------|---------------------|----------------------|---------------------|----------------------|------------------------------|------------------------|
| 15 | 130 (5.12) | 95 (3.74) | 95 (3.74) | 100 (3.94) | 145 (5.71) | 6.4 (0.25) | 2,8 (6.17) |
| 20 | 150 (5.91) | 105 (4.13) | 95 (3.74) | 125 (4.92) | 180 (7.09) | 12 (0.47) | 4 (8.82) |
| 25 | 160 (6.3) | 115 (4.53) | 95 (3.74) | 127 (5) | 183 (7.20) | 12 (0.47) | 4,6 (10.14) |
| 40 | 200 (7.87) | 150 (5.91) | 160 (6.3) | 170 (6.69) | 229 (9.02) | 18 (0.71) | 8,9 (19.62) |
| 50 | 230 (9.06) | 165 (6.5) | 160 (6.3) | 177 (6.97) | 231 (9.09) | 27 (1.06) | 11,6 (25.57) |
| 80 | 310 (12.2) | 200 (7.87) | 190 (7.48) | 232 (9.13) | 310 (12.2) | 40 (1.57) | 23,7 (52.25) |
| 100 | 350 (13.78) | 220 (8.66) | 230 (9.06) | 254 (10) | 322 (12.68) | 40 (1.57) | 33,5 (73.85) |
| 150 | 480 (18.9) | 285 (11.22) | 350 (13.78) | 378 (14.88) | 438 (17.24) | 60 (2.36) | 64,6 (142.42) |

Flange connecting dimensions:

DIN EN 1092-2, type B (ISO 7005-2, type B) PN 16
or flanges drilled to ASME B16.5 Class 150

10.10 Dimensional drawing MVM/F

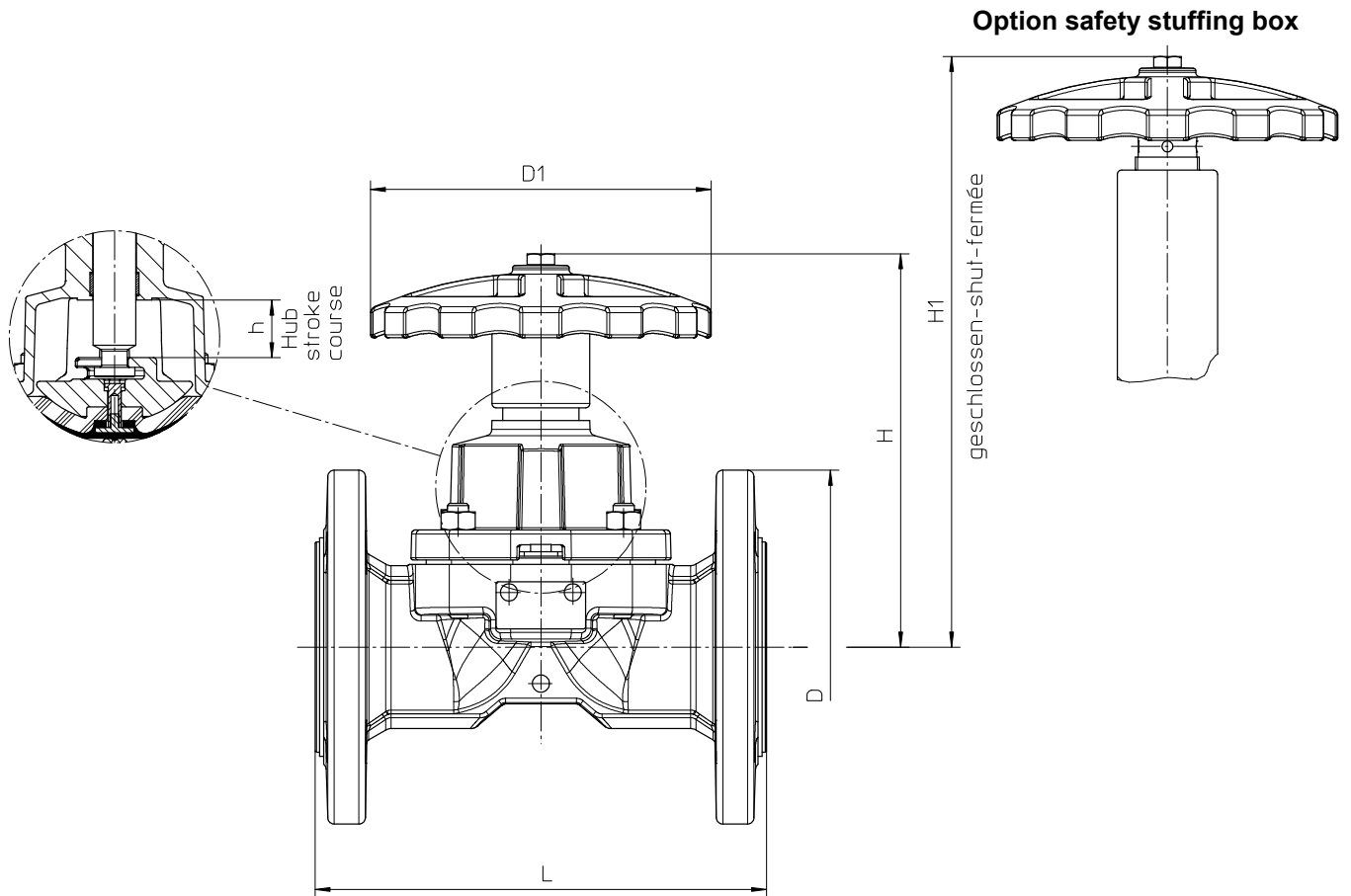

| DN | L [inch] [mm] | D [inch] [mm] | D1 [inch] [mm] | H [inch] [mm] | H1 [inch] [mm] | h (stroke) [inch] [mm] | Weight [lb] [kg] |
|-----|---------------------|---------------------|----------------------|---------------------|----------------------|------------------------------|------------------------|
| 1" | 5.8 (147,5) | 4.25 (108) | 3.74 (95) | 5 (127) | 7.2 (183) | 0.47 (12) | 9.92 (4,5) |
| 1½" | 6.89 (175) | 5 (127) | 6.3 (160) | 6.7 (170) | 9.02 (229) | 0.71 (18) | 17.42 (7,9) |
| 2" | 7.87 (200) | 6 (152,5) | 6.3 (160) | 6.97 (177) | 9.09 (231) | 1.06 (27) | 24.25 (11) |
| 3" | 10.23 (260) | 7.5 (190,5) | 7.48 (190) | 9.13 (232) | 12.2 (310) | 1.57 (40) | 50.71 (23) |
| 4" | 12.87 (327) | 8.5 (216) | 9.06 (230) | 9.92 (252) | 12.6 (320) | 1.57 (40) | 67.68 (30,7) |
| 6" | 13.38 (416) | 11 (279,5) | 13.78 (350) | 14.76 (375) | 17.13 (435) | 2.36 (60) | 132.06 (59,5) |

Flange connecting dimensions:
ASME B16.5 Class 150, raised face

10.11 Dimensional drawing MVP/F

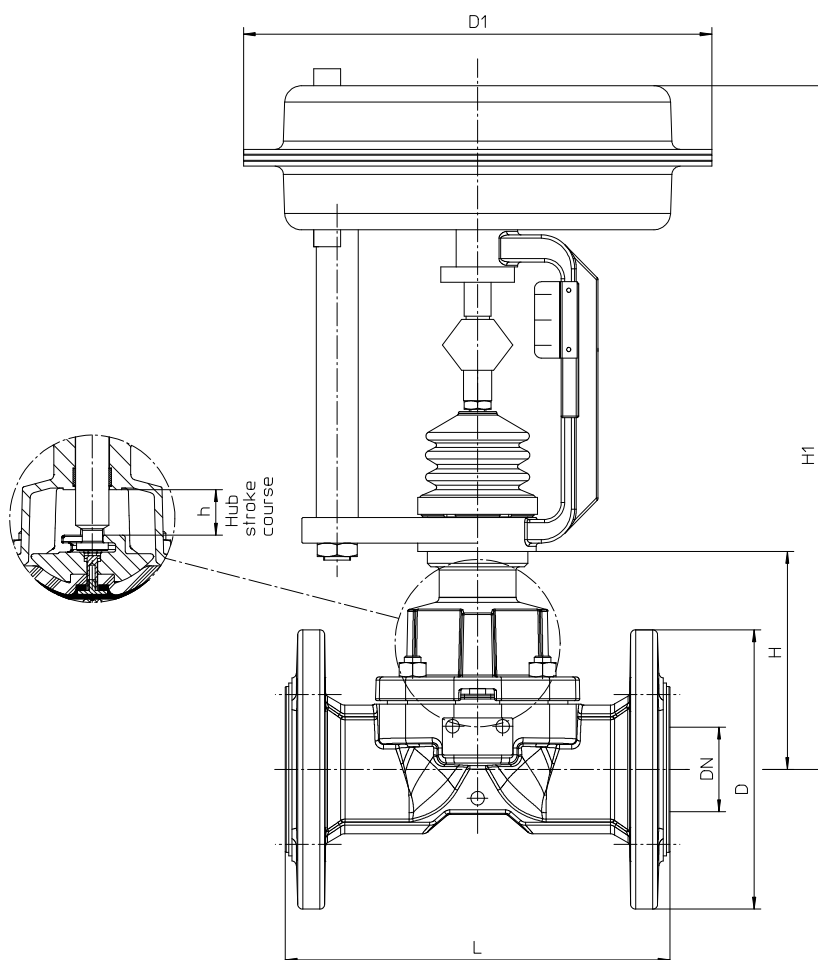

| DN | L | D | D1 | H | H1 | h (stroke) | Weight * |
|-----|----------------|----------------|----------------|----------------|----------------|----------------|-----------------|
| | [mm] [inch] | [mm] [inch] | [mm] [inch] | [mm] [inch] | [mm] [inch] | [mm] [inch] | [kg] [lb] |
| 15 | 130 (5.12) | 95 (3.74) | | 68 (2.68) | | 6.4 (0.25) | 3 (6.61) |
| 20 | 150 (5.91) | 105 (4.13) | | 89 (3.5) | | 12 (0.47) | 4,2 (9.26) |
| 25 | 160 (6.3) | 115 (4.53) | | 92 (3.62) | | 12 (0.47) | 4,8 (10.58) |
| 40 | 200 (7.87) | 150 (5.91) | | 126 (4.96) | | 18 (0.71) | 9,1 (20.06) |
| 50 | 230 (9.06) | 165 (6.5) | | 130 (5.12) | | 27 (1.06) | 12 (26.46) |
| 80 | 310 (12.2) | 200 (7.87) | | 172 (6.77) | | 40 (1.57) | 21,3 (46.96) |
| 100 | 350 (13.78) | 220 (8.66) | | 193 (7.6) | | 40 (1.57) | 29,7 (65.48) |
| 150 | 480 (18.9) | 285 (11.22) | | 275 (10.83) | | 60 (2.36) | 56,2 (123.9) |

Flange connecting dimensions:

DIN EN 1092-2, type B (ISO 7005-2, type B) PN 16
or flanges drilled to ASME B16.5 Class 150

* without actuator

Dimensions D1 and H1 vary depending on the actuator manufacturer.

10.12 Dimensional drawing MVMP/F

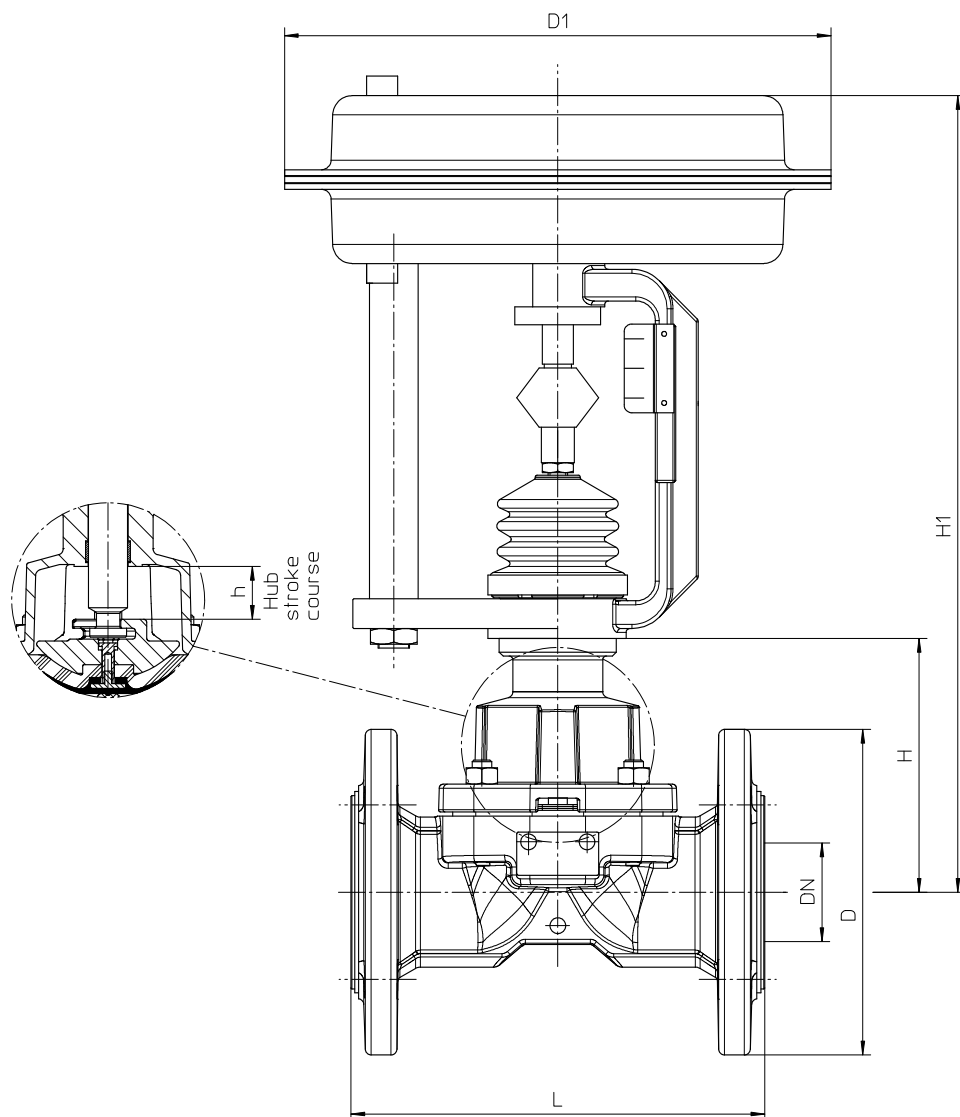

| DN | L [inch] [mm] | D [inch] [mm] | D1 [inch] [mm] | H [inch] [mm] | H1 [inch] [mm] | h (stroke) [inch] [mm] | Weight * [lb] [kg] |
|-----|---------------------|---------------------|----------------------|---------------------|----------------------|------------------------------|--------------------------|
| 1" | 5.8 (147,5) | 4.25 (108) | | 3.62 (92) | | 0.47 (12) | 9.92 (4,5) |
| 1½" | 6.89 (175) | 5 (127) | | 4.96 (126) | | 0.71 (18) | 17.42 (7,9) |
| 2" | 7.87 (200) | 6 (152,5) | | 5.13 (130) | | 1.06 (27) | 24.25 (11) |
| 3" | 10.23 (260) | 7.5 (190,5) | | 6.77 (172) | | 1.57 (40) | 50.71 (23) |
| 4" | 12.87 (327) | 8.5 (216) | | 7.52 (191) | | 1.57 (40) | 67.68 (30,7) |
| 6" | 13.38 (416) | 11 (279,5) | | 10.71 (272) | | 2.36 (60) | 132.06 (59,5) |

Flange connecting dimensions:
ASME B16.5 Class 150, raised face

* without actuator
Dimensions D1 and H1 vary depending on the actuator manufacturer.

**Konformitätserklärung nach Richtlinie 97/23/EG für
Richter Chemie-Technik GmbH Armaturen**

**Declaration of conformity according the directive 97/23/EG for
Richter Chemie-Technik GmbH valves**

Hiermit erklärt die Richter Chemie-Technik GmbH die Konformität der gelieferten Armaturen gemäß der Richtlinie 97/23/EG (Druckgeräterichtlinie).

Herewith Richter Chemie-Technik GmbH declares the conformity of the delivered valves according to the directive 97/23/EG (Pressure Equipment Directive).

Baureihe / Series: **MV/F, MVM/F, MVP/F, MVMP/F**

Anschrift des Herstellers / Manufacturer's adress:

Richter Chemie-Technik GmbH
Otto-Schott-Straße 2
D 47906 Kempen

Alle Armaturen > DN 25 welche in Kategorie I-III fallen, wurden nach Modul H der Richtlinie 97/23/EG zertifiziert.
Valves $\geq 1''$ of the category I-III are certified according to module H of the directive 97/23/EG.

Sicherheitsventile fallen in Kategorie IV und wurden nach Modul B+D der Richtlinie 97/23/EG zertifiziert.
Safety valves of the category IV are certified according to the modules B+D of the directive 97/23/EG.

Die benannte Stelle welche das Qualitätssicherungssystem und die o.g. Module der Richtlinie 97/23/EG zertifiziert:

The notified body which is responsible for the certification of the quality system and for the above mentioned modules of the PED is:

TÜV Nord Systems GmbH
Meidericher Straße 14-16
D-47058 Duisburg
Kenn.- Nr.: CE 0045

Angewandte Normen oder technische Spezifikationen:

DIN 3840, AD 2000 Regelwerk, DIN EN 12516

Other standards or technical specifications:

DIN 3840, AD 2000 Regelwerk, DIN EN 12516

Diese Erklärung verliert ihre Gültigkeit bei baulicher Veränderung, Verwendung von nicht originalen Richter Ersatzteilen und bei nicht bestimmungsgemäßer Verwendung, sofern vorher nicht ausdrücklich die schriftliche Zustimmung des Herstellers vorliegt.

This declaration will lose its validity if a structural alternation, non original spare parts from Richter or non-defined employment is made, unless the express written approval of the manufacturer is available previously.

i.V. Dipl.-Ing Ingo Zunsen
(Leiter Qualitätsmanagement / Quality Manager)

Dies ist ein Computerausdruck und ohne Unterschrift gültig.
This is a computer print and valid without signature.

Safety Information / **Declaration of No Objection** Concerning the Contamination of Richter-Pumps, -Valves and Components

1 SCOPE AND PURPOSE

Each entrepreneur (operator) carries the responsibility for the health and safety of his employees. This extends also to the personnel, who implements repairs with the operator or with the contractor.

Enclosed declaration is for the information of the contractor concerning the possible contamination of the pumps, valves and component sent in for repair. On the basis of this information for the contractor is it possible to meet the necessary preventive action during the execution of the repair.

Note: The same regulations apply to repairs **on-site**.

2 PREPARATION OF DISPATCH

Before the dispatch of the aggregates the operator must fill in the following declaration completely and attach it to the shipping documents. The shipping instructions indicated in the respective manual are to be considered, for example:

- Discharge of operational liquids
- remove filter inserts
- lock all openings hermetically
- proper packing
- Dispatch in suitable transport container
- Declaration of the contamination fixed **outside!!** on the packing

Declaration about the Contamination of Richter Pumps, -Valves and Components

The repair and/or maintenance of pumps, valves and components can only be implemented if a completely filled out declaration is available. If this is not the case, delay of the work will occur. If this declaration is not attached to the devices, which have to be repaired, the transmission can be rejected.

Every aggregate has to have it's own declaration.

This declaration may be filled out and signed only by authorized technical personnel of the operator.

| | | | |
|--|---|--|---|
| Contractor/dep./institute : _____ | | Reason for transmitting <input checked="" type="checkbox"/> Please mark the applicable | |
| Street : _____ | | Repair: <input type="checkbox"/> subject to fee <input type="checkbox"/> Warranty | |
| Postcode, city: _____ | | Exchange: <input type="checkbox"/> subject to fee <input type="checkbox"/> Warranty | |
| Contact person: _____ | | <input type="checkbox"/> Exchange/ Replacement already initiated/received | |
| Phone : _____ Fax : _____ | | Return: <input type="checkbox"/> Leasing <input type="checkbox"/> Loan <input type="checkbox"/> for credit note | |
| End user : _____ | | | |
| A. Details of Richter-product: | | Failure description: | |
| Classification: _____ | | Equipment: _____ | |
| Article number: _____ | | Application tool: _____ | |
| Serial number: _____ | | Application process: _____ | |
| B. Condition of the Richter-product: | | Contamination : | |
| | no ¹⁾ yes no | | no ¹⁾ yes |
| Was it in operation ? | <input type="checkbox"/> <input type="checkbox"/> <input checked="" type="checkbox"/> | toxic | <input type="checkbox"/> <input type="checkbox"/> |
| Drained (product/operating supply item) ? | <input checked="" type="checkbox"/> <input type="checkbox"/> <input type="checkbox"/> | caustic | <input type="checkbox"/> <input type="checkbox"/> |
| All openings hermetically locked! | <input checked="" type="checkbox"/> <input type="checkbox"/> <input type="checkbox"/> | flammable | <input type="checkbox"/> <input type="checkbox"/> |
| Cleaned ? | <input type="checkbox"/> <input type="checkbox"/> <input type="checkbox"/> | explosive ²⁾ | <input type="checkbox"/> <input type="checkbox"/> |
| If yes, with which cleaning agent: | | mikrobiological ²⁾ | <input type="checkbox"/> <input type="checkbox"/> |
| and with which cleaning method: | | radioactive ³⁾ | <input type="checkbox"/> <input type="checkbox"/> |
| | | other pollutant | <input type="checkbox"/> <input type="checkbox"/> |
| ¹⁾ if "no", then forward to D. ← ²⁾ Aggregates, which are contaminated with microbiological or explosive substances, are only accepted with documented evidence of an approved cleaning. ³⁾ Aggregates, which are contaminated with radioactive substances, are not accepted in principle. | | ↓ | |
| C. Details of the discharged materials (must be filled out imperatively) | | | |
| 1. With which materials did the aggregate come into contact ? Trade name and/or chemical designation of operational funds and discharged materials, material properties, e.g. as per safety data sheet (e.g. toxic, inflammable, caustic) | | | |
| X Trade name: _____ | | Chemical designation: _____ | |
| a) _____ | | _____ | |
| b) _____ | | _____ | |
| c) _____ | | _____ | |
| d) _____ | | _____ | |
| 2. Are the materials specified above harmful to health ? | | no yes | ← |
| | | <input type="checkbox"/> <input type="checkbox"/> | |
| 3. Dangerous decomposition products during thermal load ? | | <input type="checkbox"/> <input type="checkbox"/> | |
| If yes, which ones ? | | | |

D. Mandatory declaration: We assure that the data in this explanation are truthful and complete and as a signatory I am able to form an opinion about this. We are aware that we are responsible towards the contractor for damages, which results from incomplete and incorrect data. We commit ourselves to exempt the contractor from claims for damages of thirds resulting from incomplete or incorrect data. We are aware that we are directly responsible towards thirds, irrespective of this declaration, which belongs in particularly to the employees of the contractor consigned with the handling repair of the product.

Name of the authorized person (in block letters): _____

Date

Signature

Company stamp

FAX**Fax No. ()****Pages (incl. cover sheet) ()****To:**

()

Richter Chemie-Technik GmbH
Otto-Schott-Straße 2
D-47906 Kempen
Telefon +49 (0) 21 52/146-0
Telefax +49 (0) 21 52/146-190
richter-info@richter-ct.com
www.richter-ct.com

Contact person:
()Reference:
()Extension:
- ()E-Mail Address:
()Date:
()**Your order No.:** ()**Our Kom. No.:** ()**Serial No.:** ()

Dear Sirs,

The compliance with laws for the industrial safety obligates all commercial enterprises to protect their employees and/or humans and environment against harmful effects while handling dangerous materials.

The laws are such as: the Health and Safety at Work Act (ArbStättV), the Ordinance on Harzadous Substances (GefStoffV, BIOSTOFFV), the procedures for the prevention of accidents as well as regulations to environmental protection, e.g. the Waste Management Law (AbfG) and the Water Resources Act (WHG)

An inspection/repair of Richter products and parts will only take place, if the attached explanation is filled out correctly and completely by authorized and qualified technical personnel and is available.

In principle, radioactively loaded devices sent in, are not accepted.

Despite careful draining and cleaning of the devices, safety precautions should be necessary however, the essential information must be given.

The enclosed declaration of no objection is part of the inspection/repair order. Even if this certificate is available, we reserve the right to reject the acceptance of this order for other reasons.

Best regards
RICHTER CHEMIE-TECHNIK GMBH

Enclosures

()