

Series NKS-C, NKSP-C, NKL-C, NKLP-C

Richter Shut-off and Control Butterfly Valve

Lug-style body: Series NKL-C

Wafer-style body: Series NKS-C



Keep for future use!

This operating manual must be strictly observed before transport, installation, operation and maintenance

Subject to change without notice.

Reproduction is generally permitted with indication of the source.

© Richter Chemie-Technik GmbH

9520-072-en Revision 03 Edition 10/2012

List of Contents

List of Contents	2	7 Operation	15
Relevant documents	3	7.1 Initial commissioning.....	15
1 Technical data	3	7.2 Improper operation and their consequences	15
1.1 Overview of sizes.....	4	7.3 Shutdown	15
1.2 Type codes	4	7.3.1 Additional advice for shut-off and control butterfly valve with actuator	15
1.3 Name plate, CE and body markings	5	8 Malfunctions	16
1.4 Tightening torques	6	9 Maintenance	16
1.5 Dimensions - Installation	8	9.1 Notes for assembly.....	16
1.6 Flow rate value kv [m ³ /h]	8	9.2 Valve actuation.....	17
1.6.1 Disc/stem unit PFA-lined	8	9.2.1 Actuated with lever.....	17
1.6.2 Disc/stem unit stainless steel, Hastelloy, Titan.9		9.2.2 Actuated by means of worm gear.....	17
1.7 Weights (ca. kg).....	9	9.2.3 Remotely actuated	17
1.8 Breakaway torques	10	9.2.4 Required breakaway torque.....	17
1.9 Cavitation coefficient z for 75% duty.....	10	9.3 Tests	17
1.10 Pressure-temperature-diagram.....	10	10 Drawings	18
2 Notes on safety	11	10.1 Legend	18
2.1 Intended use	11	10.2 Sectional drawing NKS-C	18
2.2 For the customer / operator.....	11	10.3 Sectional drawing NKL-C.....	19
2.3 Improper operation.....	11	10.4 Worm gear	19
3 Safety notes for applications in potentially explosive areas based on the Directive 94/9/ EC (Atex 95)	12	10.5 Actuator.....	20
3.1 Intended use	12	10.6 Connection actuator	20
4 Safety note for valves, certified to Clean Air Act (TA-Luft)	13	10.7 Dimensional drawing NKS-C with hand lever	21
5 Transport, storage and disposal	13	10.8 Dimensional drawing NKS-C with worm gear	22
5.1 Storage	13	10.9 Dimensional drawing NKSP-C	23
5.2 Transport preparations.....	13	10.10 Dimensional drawing NKL-C with hand lever	25
5.3 Return consignments	13	10.11 Dimensional drawing NKL-C with worm gear.....	26
5.4 Transport securing device	13	10.12 Dimensional drawing NKLP-C	27
5.5 Disposal.....	14		
6 Installation	14		
6.1 Installation possibilities.....	14		
6.2 Flange caps and gaskets.....	14		
6.3 Direction of flow and installation position .	14		
6.4 Installation.....	14		
6.4.1 Additional advice for shut-off and control butterfly valve with actuator	14		
6.5 Earthing	14		

Relevant documents

- ◆ Declaration of conformity acc. to the EC Pressure Equipment Directive 97/23/EG
- ◆ Confirmation of Leakage Rate (TA-Luft)
- ◆ Form for Safety Information Concerning the Contamination QM 0912-16-2001_en
- ◆ For NKLP-C or NKSP-C, operating manual for actuator

1 Technical data

Manufacturer:

Richter Chemie-Technik GmbH
 Otto-Schott-Str. 2
 D-47906 Kempen
 Telephone: +49 (0) 2152 146-0
 Fax: +49 (0) 2152 146-190
 E-Mail : richter-info@idexcorp.com
 Internet: <http://www.richter-ct.com>

Designation:

Shut-off and control butterfly valve with lug-style and wafer-style

Disc/stem unit plastic-lined, stainless steel, Hastelloy or Titanium

Certified to Clean Air Act (TA Luft)

Strength and tightness (P10, P11) of the pressure-bearing body tested to DIN EN 12266-1.

Gas-tight (P12) in the seat to DIN EN 12266-1, leak rate A

Flange connecting dimensions:

DIN EN 1092-2, shape B, (ISO 7005-2 type B) PN 10 or ASME B16.5 class 150 (50"-24") and ASME B16.47 Class 150 (28"-40")

Face to face:

DIN EN 558-1, basic series 20 (ISO 5752 series 20)

Dimensions and individual parts:

See [Section 10](#)

Materials:

Body material: Ductile cast iron EN-JS 1049 to DIN EN 1563 (0.7043 DIN 1693)

Lining material: PTFE .../F
 PTFE modified .../F
 PTFE modified antistatic .../F-L

Disc/stem unit:

PFA-lined ...-F
 PFA-lined antistatic ...-L
 Stainless steel 1.4404, 1.4470 ...-S
 Hastelloy C22 ...-H
 Titanium Grade 2 ...-T

Temperature range: -20 °C to +200 °C
 (-4 °F to +400 °F)
 accord. to operating pressure
 See pressure-temperature diagram in [Section 1.10](#).

Operating pressure:

10 bar (145 psig) DN 50-600
 6 bar (85 psig) DN 700-1000
 accord. to operating pressure

Options:

- ◆ Polished disc surfaces

Weights: See table in [Section 1.7](#)

Dimensions and single components:

See dimensional drawings in [Section 10](#)

1.1 Overview of sizes

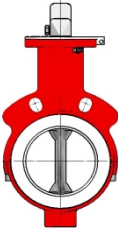
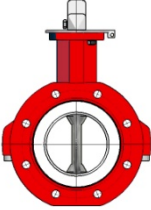
Series	Actuation	/F	/F-L	/F-S /F-H /F-T	/F-L-S /F-L-H /F-L-T	Body design
NKS-C	Lever	DN 65, 125 2½", 5"	DN 65, 125 2½", 5"	DN 50-200 2"-8"	DN 50-200 2"-8"	
	Gear		DN 65, 125, 350-400 2½", 5", 14"-16"	DN 50-300 2"-12"	DN 50-300 2"-12"	
NKSP-C	Actuator connection to ISO 5211					
NKL-C	Lever	DN 65, 125 2½", 5"	DN 65, 125 2½", 5"	DN 50-200 2"-8"	DN 50-200 2"-8"	
	Gear	DN 65, 125, 450-700 2½", 5", 18"-30"	DN 65, 125, 350-600 2½", 5", 14"-24"	DN 50-1000 2"-40"	DN 50-600 2"-24"	
NKLP-C	Actuator connection to ISO 5211					

1.2 Type codes

Series	Code
NKS-C/F wafer-style body	NKS-C
NKL-C/F lug-style body	NKL-C

Body lining	Code
PTFE	F ●
PTFE modified	T ○
PTFE modified antistatic	TL ○
PTFE modified antistatic FDA	TF ○
UHMW-PE	E ○

Material disc/stem unit	Code
PFA lined	F ●
PFA lined, antistatic	L ○
Stainless steel 1.4404, 1.4470	S ●
Hastelloy C22	H ○
Titanium Grad 2	T ○
Polished disc surfaces	ST ○

Indicate valve size	Code
DN 50, 80, 100, 125 ²⁾	

Flange connection	Code
ISO 7005-2 PN 10 tapped hole	NKL-C 1a ●
Through hole ISO	NKL-C 1 ○
ASME B16.5 or B.16.47 CL150	
Tapped hole.	NKL-C 2b ●
Through hole ASME	NKL-C 2 ○
JIS R 2210-10K	NKL-C 4 ○
No tapped or through holes	NKS-C – ●
NKS-C from DN 350 is NKL-C	
with through holes ISO	NKS-C1 ●
with through holes ASME	NKS-C2 ●

Body material	Code
Ductile cast iron EN-JS 1049	G ●
Stainless steel	S ○
C-steel	C ○
CF-GF- compound Vinylester (DN 50-300)	V ○

Flexible inlay	Code
Silicon	S ●
FKM (Viton or equal)	V ○
FDA-FKM	F ○

Actuation	Code
Lever lockable	H ●
Worm gear, with hand wheel	S ○ ● ¹⁾
Without actuation	O ○

Data on name plate	Code
°C/bar	C ●
°F/psi	F ●

- Standard
- ¹⁾ Standard up to DN 250
- Option
- ²⁾ In the certificates and „Order-related Specification“ the sizes are specified in DN (mm).

Order example NKS-CTLL80-GSHC

Order example	NKS-C	TL	L	80	-	G	S	H	C
Series	NKSP-C								
Body lining		TL							
Disc/stem unit			L						
Valve size				80					
Flange connection					-				
Body material						G			
Flexible inlay							S		
Actuation								H	
Type plate									C

1.3 Name plate, CE and body markings

The stainless steel name plate is undetachably riveted to the body.

If the operator attaches his identification, it must be ensured that the valve matches the application in question.

Example of name plate with CE marking:

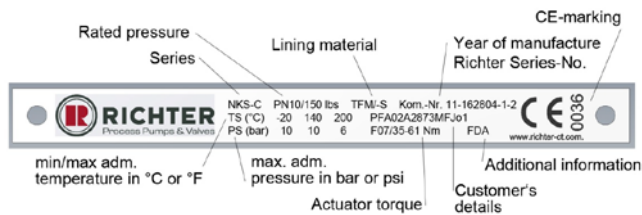

Body identification :

The following are visible on the body according to DIN EN 19 and AD 2000 A4:

- ◆ Nominal size
- ◆ Rated pressure
- ◆ Body material
- ◆ Manufacturer's identification
- ◆ Melt number/Foundry identification
- ◆ Cast date

Sign for transport securing device for actuator

Normklappen mit Antrieb
Butterfly valve with actuator
Vannes papillon avec motorisation

Vor Inbetriebnahme die Wellenblockierung (Pos.1) entfernen!
Prior to operation remove shaft locking device (Pos. 1)!

Ayant la mise en service démonter blocage de l'arbre (Pos.1)!

9500-43-1261/4-0

1.4 Tightening torques

All screws greased, tighten in diametrically opposite sequence!

After the plant has been started up (especially with the first temperature load) the tightening torques must be checked and the correct value set again.

The tightening torques for pipe screws and body screws mentioned must not be exceeded. For an exception, see **Section 8**, flange connection valve/pipe is leaking.

The following tightening torques are recommended:

Pipe screws, flanges to ISO/DIN

Standard threaded hole

Flange nom. size [mm]	Screws [ISO/DIN]	Tightening torque [Nm]
50	4 x M16	35
65	8 x M16	40
80	8 x M16	45
100	8 x M16	50
125	8 x M16	60
150	8 x M20	70
200	8 x M20	85
250	12 x M20	95
300	12 x M20	105
350	16 x M20	145
400	16 x M24	165
450	20 x M24	185
500	20 x M24	215
600	16 x M27	230
700	24 x M27	280
750	---	---
800	24 x M30	380
900	28 x M30	460
1000	28 x M33	500

Pipe screws flanges ISO/DIN drilled to ASME Class 150 Standard threaded hole

Flange nom. size		Screws [ASME]	Tightening torque	
[mm]	[inch]		[Nm]	[in-lbs]
50	2"	4 x 5/8"-11UNC	35	310
65	2½"	4 x 5/8"-11UNC	40	354
80	3"	4 x 5/8"-11UNC	45	398
100	4"	8 x 5/8"-11UNC	50	442
125	5"	8 x 3/4"-10UNC	60	532
150	6"	8 x 3/4"-10UNC	70	620
200	8"	8 x 3/4"-10UNC	85	753
250	10"	12 x 7/8"-9UNC	95	842
300	12"	12 x 7/8"-9UNC	105	931
350	14"	12 x 1"-8UNC	145	1285
400	16"	16 x 1"-8UNC	165	1463
450	18"	16 x 1½"-7UNC	185	1640
500	20"	20 x 1½"-7UNC	215	1906
600	24"	20 x 1¼"-7UNC	230	2039
700	28"	28 x 1¼"-7UNC	280	2482
---	30"	28 x 1¼"-7UNC	300	2660
800	32"	28 x 1½"-7UNC	380	3369
900	36"	32 x 1½"-6UNC	460	4078
1000	40"	36 x 1½"-6UNC	500	4433

Pipe screws, flanges to ISO/DIN, through hole

NKS-C+NKSP-C from size DN 350 (14") upwards with lug-style body and through hole

Flange nom. size [mm]	Screws [ISO/DIN]	Tightening torque [Nm]
50	4 x 18	35
65	8 x 18	40
80	8 x 18	45
100	8 x 18	50
125	8 x 18	60
150	8 x 22	70
200	8 x 22	85
250	12 x 22	95
300	12 x 22	105
350	16 x 22	145
400	16 x 26	165
450	20 x 26	185
500	20 x 26	215
600	20 x 30	230
700	24 x 30	280
750	---	---
800	24 x 33	380
900	28 x 33	460
1000	36 x 42	500

Pipe screws flanges ISO/DIN drilled to ASME Class 150, through hole

NKS-C+NKSP-C from size DN 350 (14") upwards with lug-style body and through hole

Flange nom. size		Through hole [mm]	Tightening torque	
[mm]	[inch]		[Nm]	[in-lbs]
50	2"	4 x 19	35	310
65	2½"	4 x 19	40	354
80	3"	4 x 19	45	398
100	4"	8 x 19	50	442
125	5"	8 x 22	60	532
150	6"	8 x 22	70	620
200	8"	8 x 22	85	753
250	10"	12 x 26	95	842
300	12"	12 x 26	105	931
350	14"	12 x 29	145	1285
400	16"	16 x 29	165	1463
450	18"	16 x 32	185	1640
500	20"	20 x 32	215	1906
600	24"	20 x 35	230	2039
700	28"	28 x 35	280	2482
---	30"	28 x 35	300	2660
800	32"	28 x 42	380	3369
900	36"	32 x 42	460	4078
1000	40"	36 x 42	500	4433

Body screws

Hex. socket head screws for lug-style and wafer-style bodies

Nom. size		Hex. socket head screw [ISO/DIN]	Tightening torque	
[mm]	[inch]		[Nm]	[in-lbs]
50	2"	M6x25	19.3	171
65	2½"	M6x25	19.3	171
80	3"	M8x30	46.9	415
100	4"	M10x35	93	824
125	5"	M10x35	93	824
150	6"	M10x35	93	824
200	8"	M12x40	160	1418
250	10"	M12x50	160	1418
300	12"	M16x55	395	3502
350	14"	M16x55	395	3502
400	16"	M16x55	395	3502
450	18"	M16x55	395	3502
500	20"	M16x55	395	3502
600	24"	M16x55	395	3502
700	28"	M16x80	395	3502
---	30"	M16x80	395	3502
800	32"	M20x90	773	6853
900	36"	M20x90	773	6853
1000	40"	M20x90	773	6853

1.5 Dimensions - Installation

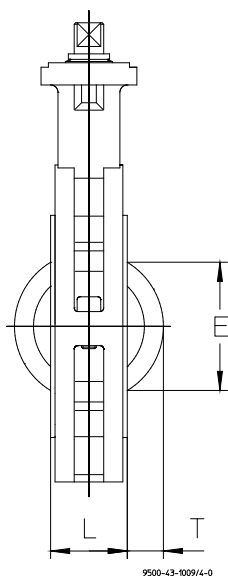

Nom. size		E ¹	T ¹	L ²	Connection ³
[mm]	[inch]	[mm]	[mm]	[mm]	
50	2"	31	6	43	F07
65	2½"	48	11	46	F07
80	3"	63	17	46	F07
100	4"	90	27	52	F07
125	5"	118	38	56	F07
150	6"	137	47	56	F07
200	8"	189	71	60	F10
250	10"	239	92	68	F10
300	12"	290	112	78	F10
350	14"	328	125	92	F12
400	16"	377	146	102	F12
450	18"	417	164	114	F14
500	20"	477	184	217	F14
600	24"	560	215	154	F16
700	28"	665	264	154	F16
750	30"	716	289	154	F25
800	32"	767	314	154	F25
900	36"	860	360	154	F25
1000	40"	970	414	154	F30

1 See also **Section 6.4, paragraph 1**

2 Face to face to DIN EN 558-1, series 20 (ISO 5752, series 20) without DN 350

3 Connections for worm gears and brackets as per DIN ISO 5211

The inside diameter of the mounted pipe flanges must always be greater than the dimension E in the table!

For more dimensions, see drawings in **Section 10**.

1.6 Flow rate value kv [m³/h]

1.6.1 Disc/stem unit PFA-lined

Nom. Size		Angle of opening							
[mm]	[inch]	20°	30°	40°	50°	60°	70°	80°	90°
65	2½"	4,4	14,0	27,4	49,4	80	118	158	211
125	5"	23,7	72	127	209	332	477	643	836
300	12"	175	506	824	1283	1982	2746	3600	4588
350	14"	243	698	1129	1742	2669	3664	4759	6024
400	16"	311	887	1424	2182	3315	4512	5807	7300
450	18"	440	1249	1993	3032	4572	6172	7871	9828
500	20"	573	1613	2558	3865	5786	7749	9795	12148
600	24"	796	2257	3601	5478	8260	11149	14218	17754
700	28"	1315	3752	6025	9231	14027	19092	24568	30887
750	30"	1402	4025	6509	10049	15394	21134	27448	34744

1.6.2 Disc/stem unit stainless steel, Hastelloy, Titan

Nom. Size		Angel of opening							
[mm]	[inch]	20°		20°		20°		20°	
50	2"	1,9	6,6	13,6	25,2	40,8	61	83	110
65	2½"	4,4	14,0	27,4	49,4	80	118	158	211
80	3"	7,4	23,2	43,9	76	122	178	243	318
100	4"	16,9	52,4	96	162	258	374	506	660
125	5"	23,7	72	127	209	332	477	643	836
150	6"	38,6	115	196	318	503	716	961	1244
200	8"	85	250	415	658	1036	1463	1956	2523
250	10"	110	320	527	827	1290	1803	2387	3064
300	12"	175	506	824	1283	1982	2746	3600	4588
350	14"	243	698	1129	1742	2669	3664	4759	6024
400	16"	311	887	1424	2182	3315	4512	5807	7300
450	18"	440	1249	1993	3032	4572	6172	7871	9828
500	20"	573	1613	2558	3865	5786	7749	9795	12148
600	24"	796	2257	3601	5478	8260	11149	14218	17754
700	28"	1315	3752	6025	9231	14027	19092	24568	30887
750	30"	1402	4025	6509	10049	15394	21134	27448	34744
800	32"	1517	4384	7147	11124	17188	23811	31217	39789
900	36"	1788	5204	8556	13437	20951	29297	38784	49778
1000	40"	1943	5656	9299	14603	22770	31841	42152	54100

1.7 Weights (ca. kg)

Nom. size		Lug style body	Sandwich-body		
[mm]	[inch]	Open staff end		Lever	Gear
50	2"	5,0	3,0	0,8	2,0
65	2½"	7,0	4,0	0,8	2,2
80	3"	8,1	5,0	0,8	2,2
100	4"	10,8	6,3	1,1	2,2
125	5"	14,5	7,7	1,1	2,2
150	6"	15,8	10,0	1,4	4,3
200	8"	24,6	16,5	1,9	4,3
250	10"	33,3	24,5	--	4,3
300	12"	57	37	--	8,5
350	14"	87	87	--	8,5
400	16"	107	107	--	8,5
450	18"	152	152	--	11,5
500	20"	185	185	--	11,5
600	24"	254	254	--	34,5
700	28"	280	280	--	34,5
750	30"	300	300	--	34,5
800	32"	410	410	--	34,5
900	36"	460	460	--	34,5
1000	40"	480	480	--	41,5

Actuator see data of the manufacturer.

1.8 Breakaway torques

Nom. size		Md _{eff}	Md _S	Md _H	Md _T
[mm]	[inch]	[Nm]	[Nm]	[Nm]	[Nm]
50	2"	26	159	103	105
65	2½"	36	159	103	105
80	3"	46	159	103	105
100	4"	60	335	216	222
125	5"	80	335	216	222
150	6"	110	608	393	402
200	8"	167	456	295	302
250	10"	278	664	457	469
300	12"	333	664	457	469
350	14"	450	1227	845	866
400	16"	500	1227	845	866
450	18"	600	1519	2004	2053
500	20"	650	1519	2004	2053
600	24"	890	3170	4181	4283
700	28"	1500	3170	4181	4283
750	30"	2000	5418	7147	7321
800	32"	2300	5418	7147	7321
900	36"	2700	5418	7147	7321
1000	40"	3400	10374	7147	7321

Md_{eff} = incl. 10% safety Md_H = Hastelloy stem
 Md_S = Stainless steel stem Md_T = Titanium stem

1.9 Cavitation coefficient z for 75% duty

Nom. size		at kv/kvs = 75 %
[mm]	[inch]	z
50	2"	0,60
65	2½"	0,46
80	3"	0,47
100	4"	0,27
125	5"	0,40
150	6"	0,38
200	8"	0,29
250	10"	0,48
300	12"	0,45
350	14"	0,48
400	16"	0,56
450	18"	0,49
500	20"	0,49
600	24"	0,48
700	28"	0,29
750	30"	0,30
800	32"	0,30
900	36"	0,31
1000	40"	0,40

1.10 Pressure-temperature-diagram



When used in the minus temperature range, the regulations applicable in the country in question must be observed.

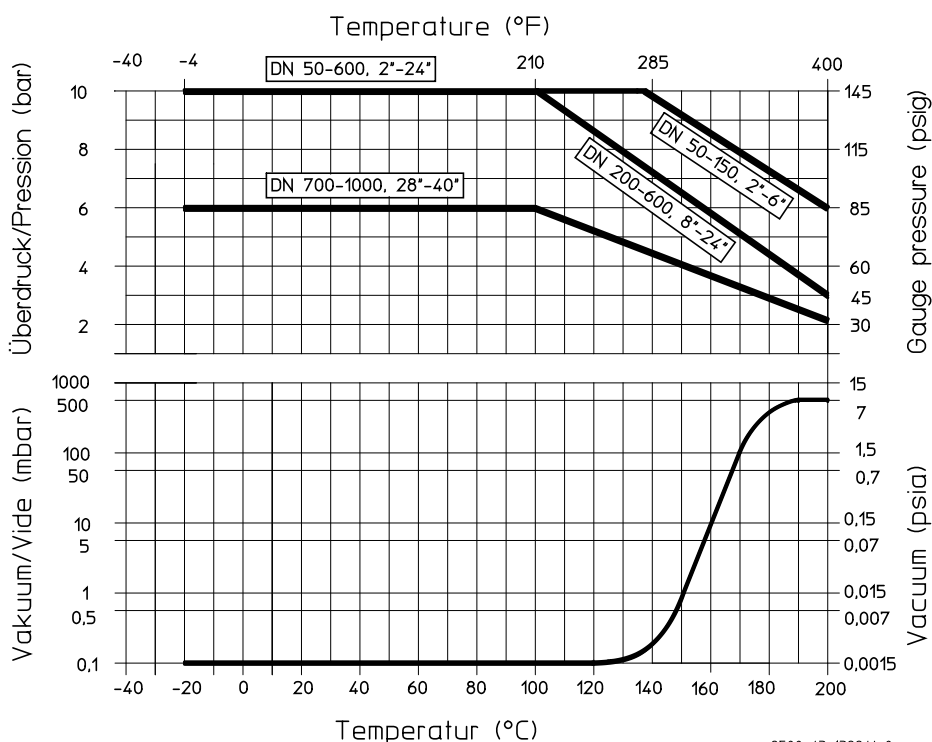

9500-43-1399/4-0

2 Notes on safety

This operating manual contains fundamental information which is to be observed during installation, operation and maintenance.

It must therefore be read before installation and commissioning!

For valves which are used in potentially explosive areas, see **Section 3**.

Installation and operation are to be performed by qualified staff.

The area of responsibility, authority and supervision of the staff must be regulated by the customer.



General hazard symbol!

People may be put at risk.



Safety symbol! The ball valve and its function may be put at risk if this safety symbol is not observed.

It is imperative to observe warnings and signs attached directly to the ball valve and they are to be kept fully legible.

Non-observance of the notes on safety may result in the loss of any and all claims for damages.

For example, non-observance may involve the following hazards:

- ◆ Failure of important functions of the valve/plant.
- ◆ Risk to people from electric, mechanical and chemical effects.
- ◆ Risk to the environment through leaks of hazardous substances.

2.1 Intended use

Shut-off and control butterfly valves are pressure-maintaining components in accordance with the German Pressure Equipment Directive (DGRL) for the passage and shut-off of fluids. The valves are suitable for vapours, gases and liquids of group 1 according to the DGRL and have a corrosion-resistant plastic lining.

The field of application for the shut-off and control butterfly valves include:

- ◆ Light and medium corrosive, pure and slightly solids-laden liquids, vapours and gases
- ◆ Materials in contact with the medium which are FDA-compliant can be used for food and pharmaceutical feedstock as well as in biochemistry.
- ◆ Powdered and granulated non or low abrasive solids

Shut-off and control butterfly valves with a plastic-lined disc/stem unit are used for highly aggressive, corrosive media.

Shut-off and control butterfly valves with a stainless steel disc/stem unit are suitable for less aggressive media, are cheaper and beneficial for thorough valve cleaning.

With both body designs the butterfly valves can be installed as a wafer-style valve (sandwich-type butterfly valve).

Product features:

- ◆ Wide sealing surfaces of the body lining
- ◆ Long valve neck for optimum heat insulation
- ◆ Maintenance-free, self-adjusting stem seal
- ◆ Leak-proof to the atmosphere in accordance with the German Clean Air Code

Solids can lead to increased wear, leaks, damage to sealing surfaces or to a reduction in the service life of the valve.

In case of the valve is intended for operating data other than those intended, the customer must carefully examine whether the design of the valve, accessories and materials are suitable for the new application (consult the manufacturer).

2.2 For the customer / operator

If a safety valve is used, the operator must ensure that

- ◆ actuators which are retrofitted are adapted to suit the valve
- ◆ hot or cold valve parts are protected by the customer against being touched
- ◆ the valve has been properly installed in the pipe system
- ◆ the operating conditions stipulated in the data sheet are not exceeded in continuous operating mode.

This is not the manufacturer's responsibility.



Butterfly valves which are used as end valves must be sealed with a blind flange at the free connection end and appropriately secured against unauthorized activation.

Loads caused by earthquakes were not allowed for in the design.

Fire protection to DIN EN ISO 10497 is not possible (plastic lining and plastic components).

2.3 Improper operation

The operational reliability of the valve supplied is only guaranteed if it is used properly in accordance with **Section 2.1** of this operating manual.



The operation limits specified on the identification plate and in the pressure-temperature diagram must under no circumstances be exceeded.

3 Safety notes for applications in potentially explosive areas based on the Directive 94/9/ EC (Atex 95)

The valves are intended for use in a potentially explosive area and are therefore subject to the conformity assessment procedure of the directive 94/9/EC (ATEX).

As part of this conformity assessment, an ignition hazard analysis to EN 13463-1 to satisfy the fundamental safety and health requirements was conducted with the following result:

- ◆ **The valves do not have any ignition source of their own and can be operated both manually as well as mechanically/electrically.**
- ◆ **The valves are not covered by the scope of application of the ATEX directive and therefore do not need to be identified accordingly.**
- ◆ **The valves may be used in a potentially explosive area.**

Supplementary notes:

- ◆ **Electric/mechanical actuators must be subjected to their own conformity assessment to ATEX.**

It is imperative to observe the individual points of intended use for application in a potentially explosive area.

3.1 Intended use

Inadmissible modes of operation, even for brief periods, may result in serious damage to the unit.

In connection with explosion protection, potential sources of ignition (overheating, electrostatic and induced charges, mechanical and electric sparks) may result from these inadmissible modes of operation; their occurrence can only be prevented by adhering to the intended use.

Furthermore, reference is made in this connection to the Directive 95/C332/06 (ATEX 118a) which contains the minimum regulations for improving the occupational health and safety of the workers who may be at risk from an explosive atmosphere.

A difference is made between two cases for the use of chargeable liquids (conductivity $<10^{-8}$ S/m):

1. Chargeable liquid and non-conductive lining

Charges can occur on the lining surface. As a result, this can produce discharges inside the valve. However, these discharges cannot cause ignitions if the valve is completely filled with medium.

If the valve is not completely filled with medium, e.g. during evacuation and filling, the formation of an explosive atmosphere must be prevented, e.g. by superimposing a layer of nitrogen.

It is recommended to wait 1 hour before removing the valve from the plant in order to permit the elimination of static peak charges.

This means that, to safely prevent ignitions, the valve must be completely filled with medium at all times or else a potentially explosive atmosphere must be excluded by superimposing a layer of inert gas.

2. Chargeable liquid and conductive lining

No hazardous charges can occur as charges are discharged direct via the lining and shell (surface resistance $<10^9$ Ohm, leakage resistance $<10^6$ Ohm).

Static discharges of non-conductive linings are only produced through the interaction with a non-conductive medium and are therefore the responsibility of the plant operator.

Static discharges are not sources of ignition which stem from the valves themselves!

- The temperature of the medium must not exceed the temperature of the corresponding temperature class or the maximum admissible medium temperature as per the operating manual.
- If the valve is heated (e.g. heating jacket), it must be ensured that the temperature classes prescribed in the Annex are observed.
- To achieve safe and reliable operation, it must be ensured in inspections at regular intervals that the unit is properly serviced and kept in technically perfect order
- Increased wear to the valve can be expected with the conveyance of liquids containing abrasive constituents. The inspection intervals are to be reduced compared with the usual times.
- Actuators and electric peripherals, such as temperature, pressure and flow sensors etc., must comply with the valid safety requirements and explosion protection provisions.
- The valve must be grounded.
This can be achieved in the simplest way via the pipe screws using tooth lock washers. Otherwise grounding must be ensured by other action, e.g. cable bridges.
- Attachments such as actuators, position controllers, limit switches etc. must satisfy the relevant safety regulations as regards explosion protection and, if required, be designed in compliance with ATEX.
- Special attention must be paid to the appropriate safety and explosion protection notes in the respective operating manuals.
- Plastic-lined valves must not be operated with carbon disulphide.

4 Safety note for valves, certified to Clean Air Act (TA-Luft)

On request, this valve can be supplied compliant with the German Clean Air Code.

Certificate / Manufacturer Declaration Validity is dependent on the operating instructions being read and observed.

In particular, servicing must be conducted at regular intervals, and the bolted connections relevant for tightness must be inspected and retightened if necessary.

5 Transport, storage and disposal



It is imperative, for all transport work, to observe generally accepted engineering practice and the accident prevention regulations.

Handle the goods being transported with care. During transport the valve must be protected against impacts and collisions.

Directly after receipt of the goods, the consignment must be checked for completeness and any in-transit damage.

Do not damage paint protection.

5.1 Storage

If the valve is not installed immediately after delivery, it must be put into proper storage.

It should be stored in a dry, vibration-free and well-ventilated room at as constant a temperature as possible.

Elastomers are to be protected against UV light.

In general, a storage period of 10 years should not be exceeded.

It is not permitted to put the valve into store with the disc completely closed or with an opening angle greater than 15°.

5.2 Transport preparations

During transport the disc/stem unit must not project beyond the body dimensions.

Hand lever:

When the valve is in the closed position, the lever is to lock in the first lever catch. This results in the disc/stem unit being slightly opened.

Worm gear

When the valve is in the closed position, the disc/stem unit is to be 10-15° open.

Actuator

When the valve is in the closed position, the disc/stem unit is to be 10-15° open.

Attach a locking plate on shut-off and control butterfly valves with a single-acting actuator. See also **Section 6.4.1** and the drawing in **Section 5.4**.

Mount flange caps.

5.3 Return consignments



Valves which have conveyed aggressive or toxic media must be well rinsed and cleaned before being returned to the manufacturer's works.

It is **imperative** to enclose a **safety information sheet / general safety certificate** on the field of application with the return consignment.

Pre-printed forms are enclosed with the installation and operating manual.

Safety precautions and decontamination measures are to be mentioned.

5.4 Transport securing device

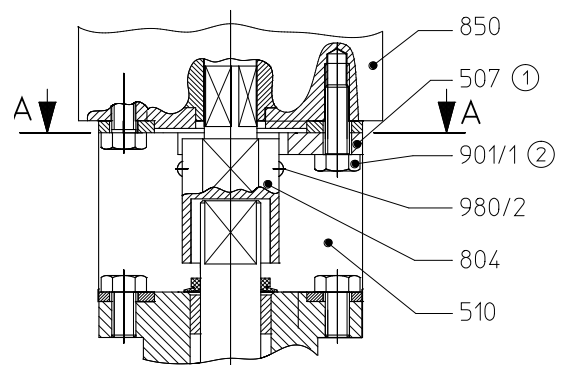

- ① Only with single acting actuator. Remove it at installation. See also **Section 6.4.1**.
- ② Screw in again the hex. nuts after removing the locking plate.

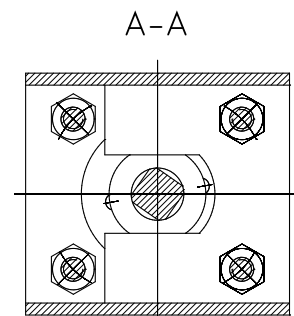

9500-43-1137_en/4-0

Drawing is also valid for NKL, NKS und NK with a commercial worm gear.

5.5 Disposal

Parts of the valve may be contaminated with medium which is detrimental to health and the environment and therefore cleaning is not sufficient.



Risk of personal injury or damage to the environment due to the medium!

- ◆ Wear protective clothing when work is performed on the valve.

- ◆ Prior to the disposal of the valve:
 - Collect any medium, etc. which has escaped and dispose of it in accordance with the local regulations.
 - Neutralize any medium residues in the valve.
- ◆ Separate valve materials (plastics, metals etc.) and dispose of them in accordance with the local regulations.

6 Installation

- ◆ Examine valve for in-transit damage, damaged diaphragm valves may not be installed.
- ◆ Before installation the valve and the connecting pipe must be carefully cleaned to remove any dirt, especially hard foreign matter.
- ◆ During installation, pay attention to the correct tightening torque, aligned pipes and tension-free assembly.



Ensure that a remotely actuated actuator cannot be accidentally switched on.

6.1 Installation possibilities

Series NKS-C wafer-style body

They are used for sandwich installation. The valve is clamped between the two pipes. From DN 350 upwards a lug-style body with through holes is standard

Series NKL-C lug-style body

They are suitable as an intermediate flange and dead-end valve.

On request, through holes can also be provided instead of the tapped bores.

6.2 Flange caps and gaskets

Leave the original packaging on the valve until immediately before installation.

NKS-C with TFM body lining does not need any gaskets.

If plastic sealing surfaces can be damaged, e.g. by mating flanges made of metal or enamel, use PTFE-lined gaskets with a metal inlay.

6.3 Direction of flow and installation position

Installation is independent of the direction of flow.

Any fitting position can be chosen.

Except solids-containing liquids:

With solid containing media butterfly valves are preferably installed with horizontally positioned stem and bottom half of disc opening into flow direction.

6.4 Installation

- Can the disc open in the pipeline?
For dimensions see **Section 1.5**.
- Is the disc open 10 – 15°?
- Mount butterfly valve and gaskets centrally.
- Tighten the piping bolts crosswise and hand-tight.
- By means of a test actuation ensure that the disc is able to freely rotate.
- With the disc slightly opened, tighten the piping bolts crosswise. For the torques see **Section 1.4**.



Butterfly valves which are used as end valves must be sealed with a blind flange at the free connection end and appropriately secured against unauthorised activation.

6.4.1 Additional advice for shut-off and control butterfly valve with actuator

- For single-acting actuators a locking plate has been fitted into the bracket, blocking the stem at a disc opening of 10 – 15°.
- Remove the locking plate before the first test actuation, screw in again hex. screw **901/1**. Slightly actuate the actuator.
Please pay attention to the drawing in **Section 5.4**.

6.5 Earthing

On request, the butterfly valves are supplied with an earthing connection.

7 Operation

7.1 Initial commissioning

Normally, the valves have been tested for leaks with air or water. Prior to initial operation check body bolting. For torques see [Section 1.4](#).



Unless otherwise agreed, there could be residual amounts of water in the flow section of the valve; this could result in a possible reaction with the medium.

To prevent leaks, all connection screws should be retightened after the initial loading of the valve with operating pressure and operating temperature.

For torques see [Section 1.4](#).

7.2 Improper operation and their consequences

- ◆ Do not operate the butterfly valve without valve actuation. Otherwise the disc will be uncontrollably set in motion by the medium flow.
- ◆ Butterfly valves with a hand lever should never be abruptly opened or closed. This can lead to water hammer effects.
- ◆ Dissipate thermal expansion volumes in shut-off pipes.
- ◆ If the plastic swells up due to the effect of the medium, this can result in the functional parts jamming.
- ◆ Operation with solids leads to increased wear.
- ◆ There must be no foreign matter on the sealing surfaces.
- ◆ Operation during cavitation leads to increased wear.
- ◆ Non-observance of the pressure-temperature diagram can lead to damage of the plastic lining.
- ◆ If no monitoring is provided by the warning connection, do not tighten safety stuffing box. Otherwise any leak cannot be seen.
- ◆ Do not apply heavy loads to the lever; the lever or butterfly valves may be damaged.
- ◆ Do not use a lever extension as this could cause damage.

7.3 Shutdown

Before loosening the flange bolts:



- ◆ ensure plant to be free of pressure
- ◆ flush out medium
- ◆ observe safety regulations

Prior to starting any repair work, the valve is to be thoroughly cleaned. Even if the valve has been properly emptied and rinsed, residual medium may still be found in the valve,

In addition to suitable protective clothing, wear working gloves and goggles for assembly and maintenance work.

After dismantling, immediately protect the valve flanges against mechanical damage with flange caps. See also [Section 6.2](#).

7.3.1 Additional advice for shut-off and control butterfly valve with actuator



Ensure that a remotely actuated quarter-turn actuator cannot be accidentally switched on.

- Having dismantled the valve, mount the locking plate **507** and screw in with hex. screw **901/1**.

See also [Section 6.4.1](#) and drawing in [Section 5.4](#).

8 Malfunctions

- ◆ Flange connection ball valve/pipe is leaking
Retighten the flange screws to a tightening torque according to **Section 1.3**. If this does not remedy the leak, the recommended torques may be exceeded by 10%.
If this also fails to stop the leak, dismantle and inspect the ball valve.
Dismount and inspect the valve.
- ◆ Stem passage leaking
With no safety stuffing box:
Dismount valve and repair.
With safety stuffing box:
First of all, the packing gland follower can be tightened. For torques see **Section 1.3**.
Then dismantle the valve as quickly as possible and repair.
- ◆ Medium leaking at the partition between lower and upper halves
Dismont valve and repair, probably the stem seal is not tight.
- ◆ Valve does not switch
Has the locking plate been dismantled?
See **Section 5.4**.
Is the actuator supplied with power?
Has a directional control valve been correctly connected?
Is there foreign matter in the valve?
- ◆ The bore of the valve is leaking
Wear at the valve actuation ?
Do limit stops have to be adjusted?
Is the shaft deformed?
Deformation, damage or wear to body lining or disc?

9 Maintenance

- ◆ All repair work is to be performed by qualified personnel using the appropriate tools.
- ◆ For the arrangement, designation and item numbers of all parts of the valve, see **Section 10**.
- ◆ Spare parts are to be ordered with all the details in acc. with the valve identification.
- ◆ Only original spare parts may be installed.
- ◆ To prevent leaks, a regular check of the connection screws should be made in line with the operating requirements.
For torques see **Section 1.4**.
- ◆ When disassembling and assembling the valve, attention is to be paid to the tables and drawings in **Section 1 and 10**.
- ◆ As the body lining **409** is drawn over the disc/stem unit **221** while warm, this work should only be carried out by the manufacturer.
- ◆ Has the pump been shut down, drained and flushed according to the regulations?
See also **Section 7.3**.



If assembled incorrectly, individual components of the valve may be damaged and this can result in malfunctions during operation.

9.1 Notes for assembly

- The flexible inlay **521** expands during assembly. Do not cut off the overhang, but push back into the lower and upper part of the shell **120**.
 - Before tightening the body screws **914/1** align the disc/stem unit **221** centrally in the closed position.
 - Mark the position of the disc/stem unit **221** against body lining **409** at the hub, so permitting switching only to this point during later test switching.
 - With disc/stem unit in closed position, tighten the body screws (**914/1**, as well **918/1** and **929/2**) until the gap between the upper and lower part of the shell **120** is ca. 5 mm.
 - Open the valve several times counterclockwise (when viewing the stem unit) and close again in the opposite direction. A sealing edge can form in this way.
-  **Never switch in the other direction of rotation over the sealing edge!**
- Tighten the body bolts 1-2 mm when disc in closed position.
 - Repeat the previously described process once or twice.
 - When finally tightening the body bolts, pay attention to the torques provided in **Section 1.4**.

9.2 Valve actuation

The disc/stem unit has a 2-surface pivot point on DN 50-150 (2" - 6") and a 4-surface pivot point on DN 200-1000 (8" - 40") for mounting a hand lever or coupling.

Hand lever or 2/4-surface pivot point parallel to the pipe axis: → **Valve open**

Hand lever or 2/4-surface pivot point at right angles to the pipe axis: → **Valve closed**

In the case of a coupling, 2 red marks indicate the position of the disc on them.

Marks parallel to the axis of the pipeline:
→ **Valve open**

Marks at right angles to the axis of the pipeline:
→ **Valve closed**

9.2.1 Actuated with lever

The throttling plate **519** permits a fixing of the lever at 10° intervals. It is lockable with a commercially available padlock.

9.2.2 Actuated by means of worm gear

In the standard version, the manufacturer normally provides worm gears with a special pick-up for the stem pivot.

The bracket and the coupling are thereby not required.

9.2.3 Remotely actuated

Richter butterfly valves can be remotely actuated by means of pneumatic, hydraulic or electric quarter-turn actuators equipped with a connection as per DIN EN ISO 5211.

Couplings and brackets are available as accessories in the Richter range of products.

9.2.4 Required breakaway torque



The breakaway torque of the actuator must be at least as high as the breakaway torque of the butterfly valve, about 20% higher being better however.

Media of higher viscosity and/or those with solids may require an increased factor of safety when calculating the size of the actuator. This is particularly true for non-Newtonian fluids such as high polymer substances, suspensions, pastes, lubricants, resins, lacquers etc.

Admissible factors of safety lie in the range of 20 - 50% of the breakaway torque.

To prevent damage to the valve, particular attention must be paid to the torque M_{dmax} in **Section 1.8**.

9.3 Tests

Following tests would be done after the assembly.

Measurement of the breakaway torque

The breakaway torque required for opening and closing the valve is to be ascertained. The maximum torque should not exceed the values given in **Section 1.8**.

Tightness of valve opening and shaft bushing

The completed valves have to undergo a „leak test of the closure with air“.

10 Drawings

10.1 Legend

120	shell
221	disc/stem unit
313/x	bearing and pressure package
409	body lining
521	flexible inlay
532	grounding rope
914/1	hex. socket screw
936/1	toothed lock washer

<u>Lever unit</u>	
235	lever assembly
519	throttling plate

<u>Worm gear</u>	
857	worm gear

<u>Actuator</u>	
510	bracket
804	coupling
850	actuator

10.2 Sectional drawing NKS-C

Wafer-style body with hand lever

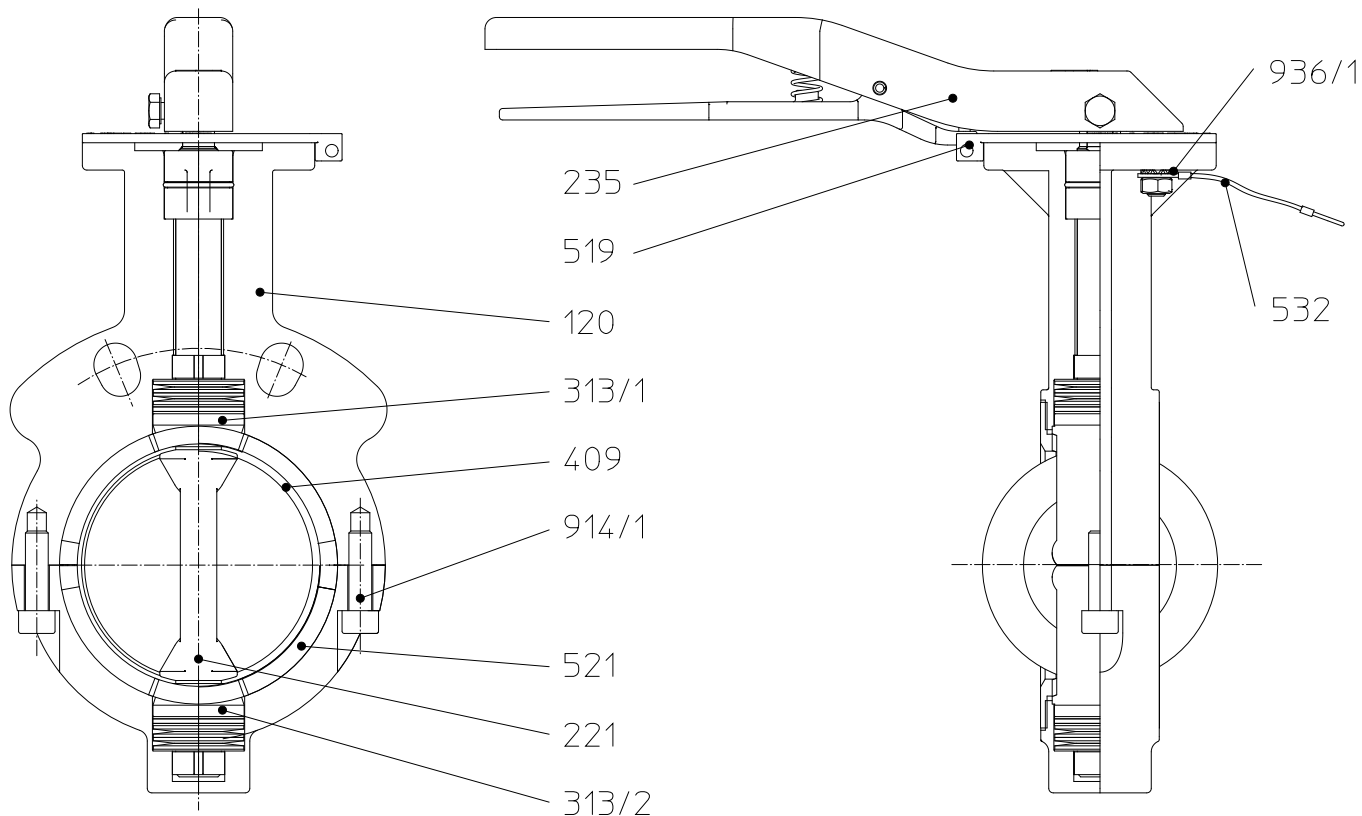

9520-00-3290/4-0

10.3 Sectional drawing NKL-C

Lug-style body with hand lever

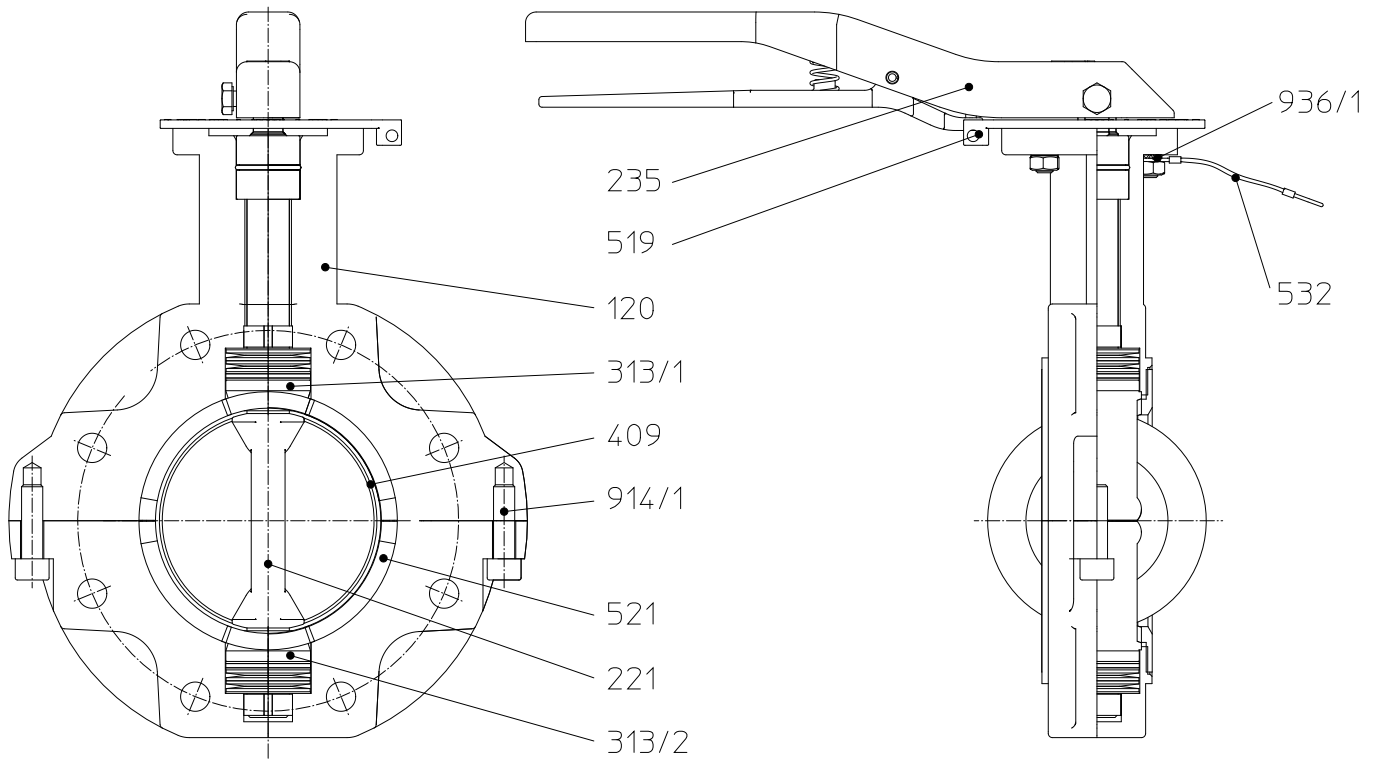

9500-43-1402/4-0

10.4 Worm gear

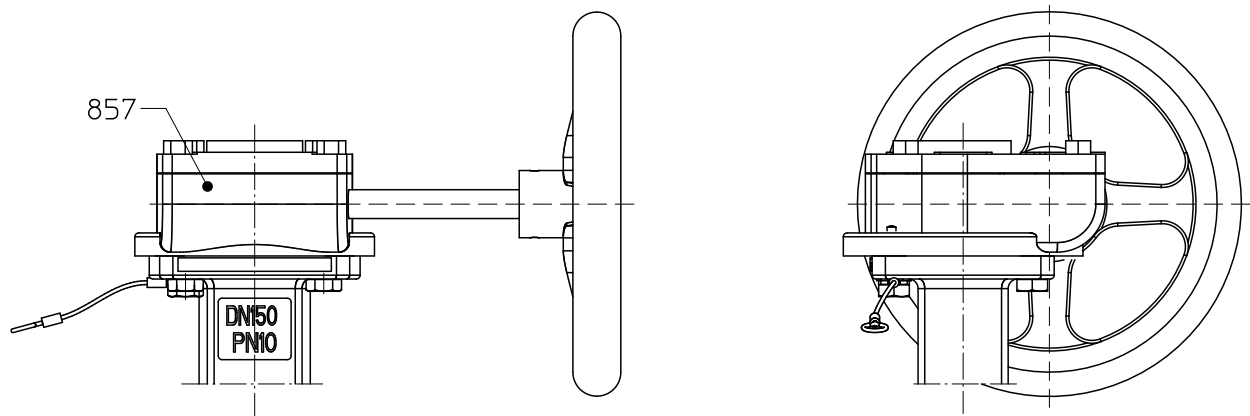

10.5 Actuator

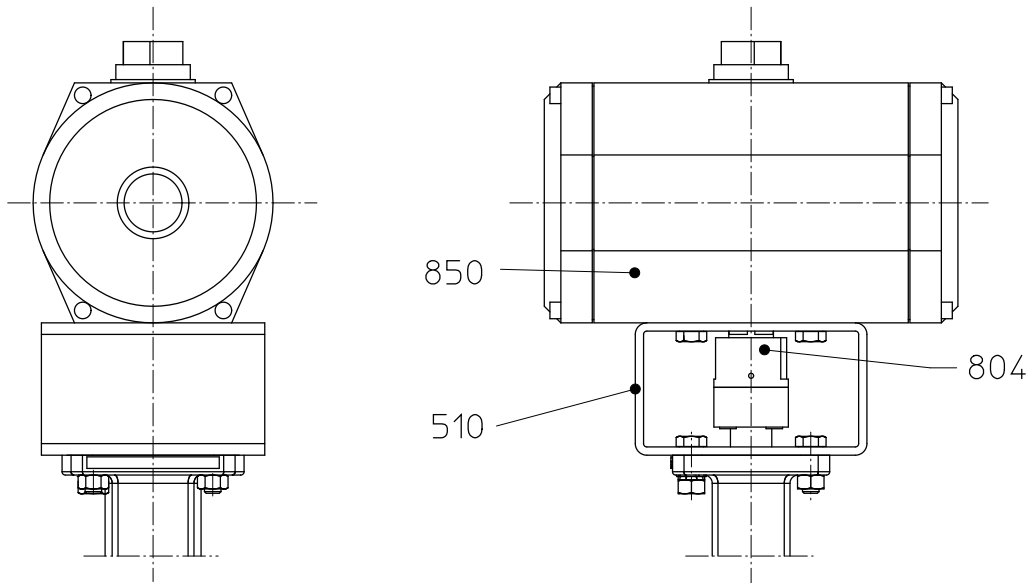

10.6 Connection actuator

Connection flange to ISO 5211

DN		ØD	A	2-surface pivot point		4-surface pivot point		ØP	T
[mm]	[inch]			ØS	SW	ØS	SW		
50	2"	102	19	14	11	--	--	56	3,5
65	2½"	102	19	14	11	--	--	56	3,5
80	3"	102	19	14	11	--	--	56	3,5
100	4"	102	25	18	14	--	--	56	3,5
125	5"	102	25	18	14	--	--	56	3,5
150	6"	102	30	22	17	--	--	56	3,5
200	8"	152	26	--	--	24	19	71	3,5
250	10"	152	30	--	--	28	22	71	3,5
300	12"	152	30	--	--	28	22	71	3,5
350	14"	152	37	--	--	36	27	87	3,5
400	16"	152	37	--	--	36	27	87	3,5
450	18"	175	50	--	--	48	36	102	4,5
500	20"	175	50	--	--	48	36	102	4,5
600	24"	210	64	--	--	60	46	132	5,5
700	28"	210	64	--	--	60	46	132	5,5
750	30"	300	56	--	--	72	55	132	5,5
800	32"	300	56	--	--	72	55	202	5,5
900	36"	300	56	--	--	72	55	202	5,5
1000	40"	300	76	--	--	98	75	232	5,5

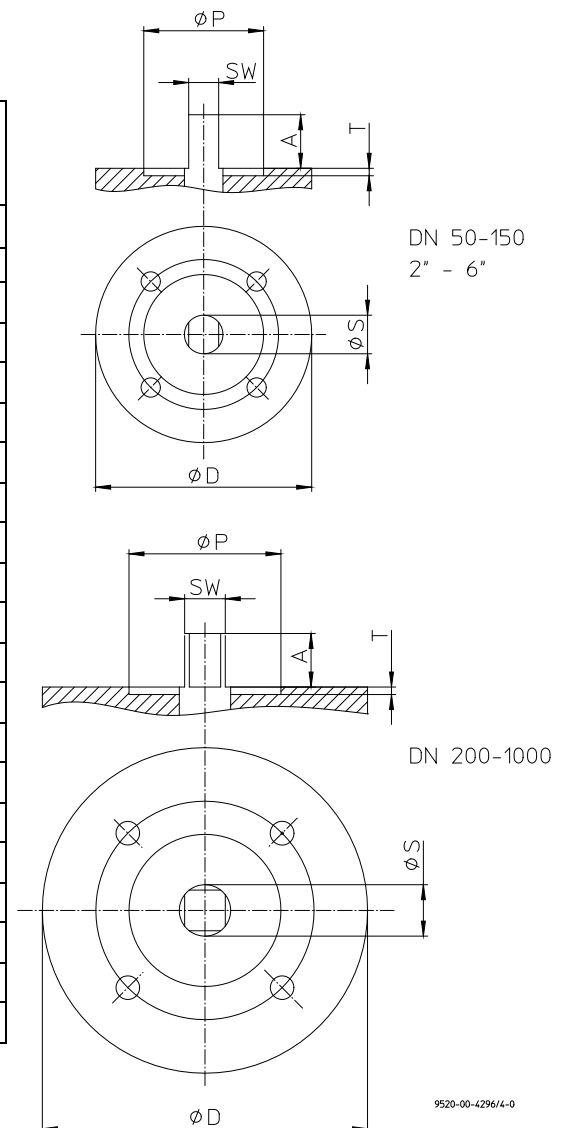

10.7 Dimensional drawing NKS-C with hand lever

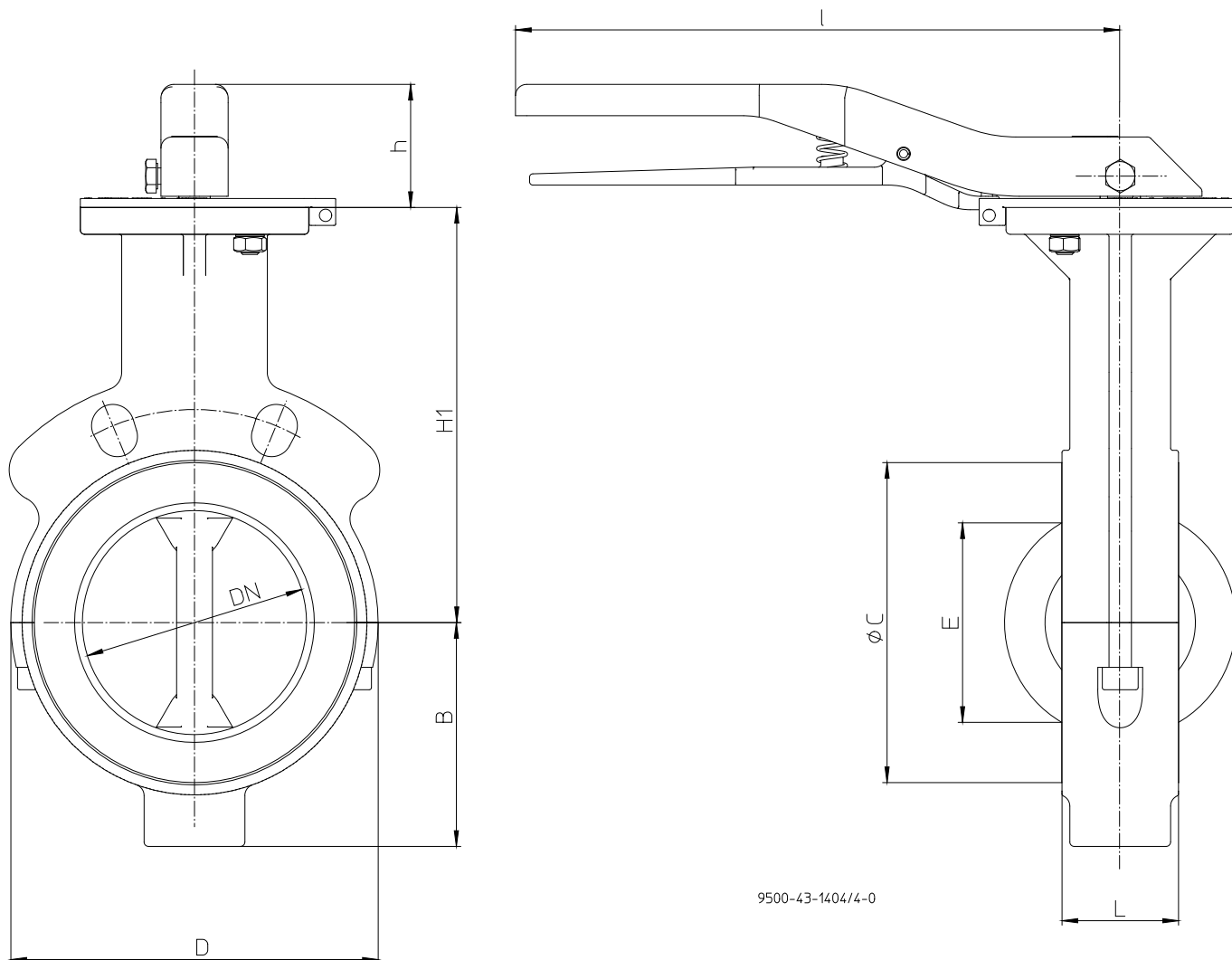

DN		H1	h	B	l	L	D	øC	E
[mm]	[inch]	[mm]							
50	2"	130	46	56	230	33	104	85	31
65	2½"	146	46	67	230	43	128	106	48
80	3"	165	46	84	230	46	144	122	63
100	4"	185	55	100	270	46	164	143	90
125	5"	202	55	110	270	52	194	166	118
150	6"	217	55	125	325	56	220	193	137
200	8"	245	55	158	349	56	274	251	189
250	10"	Only with worm gear							
300	12"								
350	14"								
400	16"								
450	18"								
500	20"								
600	24"								
700	28"								
750	30"								
800	32"								
900	36"								
1000	40"								

10.8 Dimensional drawing NKS-C with worm gear

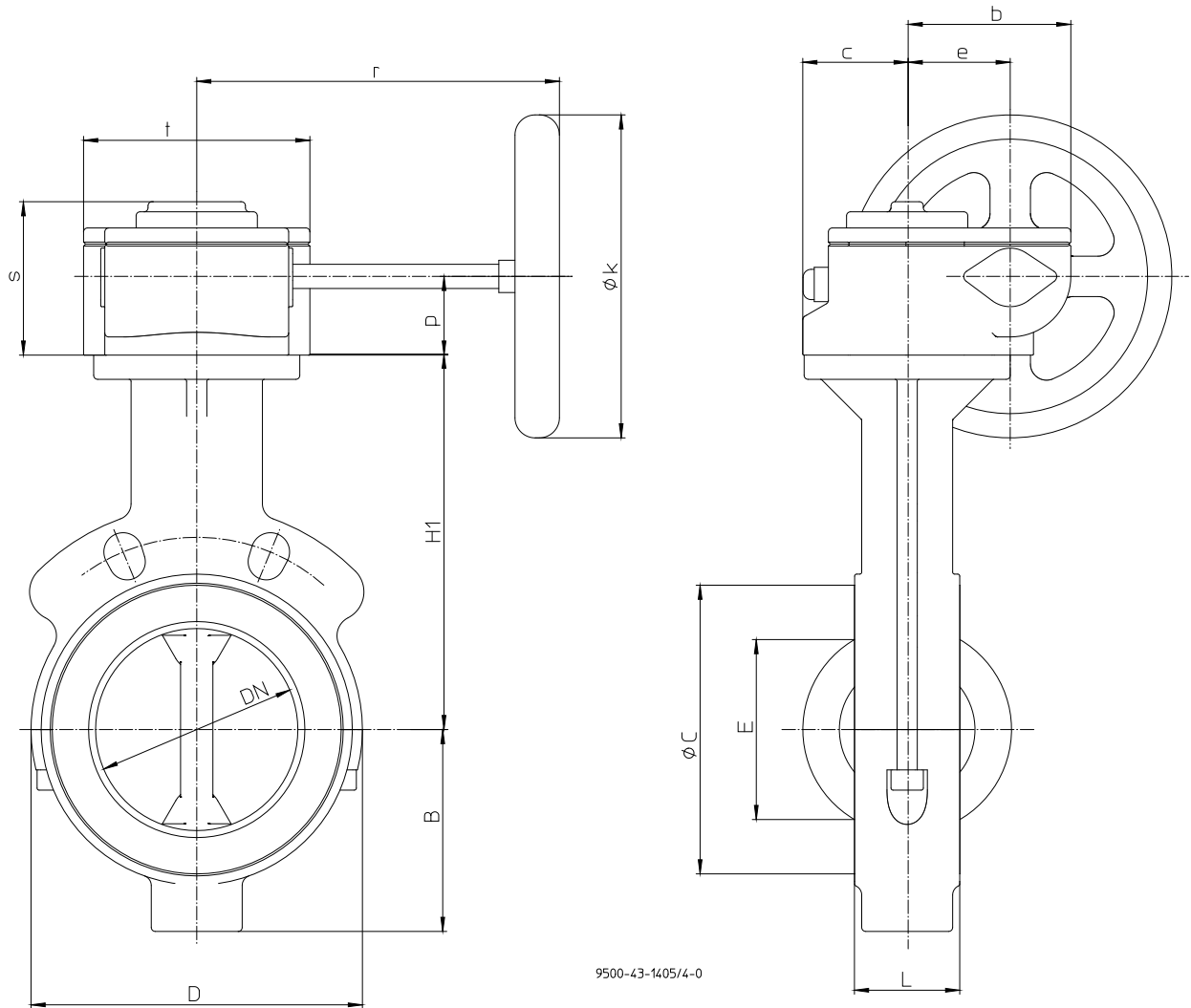

DN		H1	B	L	D	ØC	E	p	Øk	r	s	t	c	e	b
[mm]	[inch]	[mm]													
50	2"	130	56	43	104	85	31	28,5	125	128	64	84	45,7	43,5	67,5
65	2½"	146	67	46	128	106	48	28,5	125	128	64	84	45,7	43,5	67,5
80	3"	165	84	46	144	122	63	28,5	125	128	64	84	45,7	43,5	67,5
100	4"	185	100	52	164	143	90	28,5	125	128	64	84	45,7	43,5	67,5
125	5"	202	110	56	194	166	118	28,5	125	128	64	84	45,7	43,5	67,5
150	6"	217	125	56	220	193	137	34	200	215	75	112	55	52,5	81,5
200	8"	245	158	60	274	251	189	34	200	215	75	112	55	52,5	81,5
250	10"	270	190	68	330	301	239	34	200	215	75	112	55	52,5	81,5
300	12"	308	225	78	380	349	290	42,5	250	265,5	90,5	135	72,5	68,8	115
350	14"	From DN 350 (14") Lug-style body NKL-C with through holes													
400	16"														
450	18"														
500	20"														
600	24"														
700	28"														
750	30"														
800	32"														
900	36"														
1000	40"														

10.9 Dimensional drawing NKSP-C

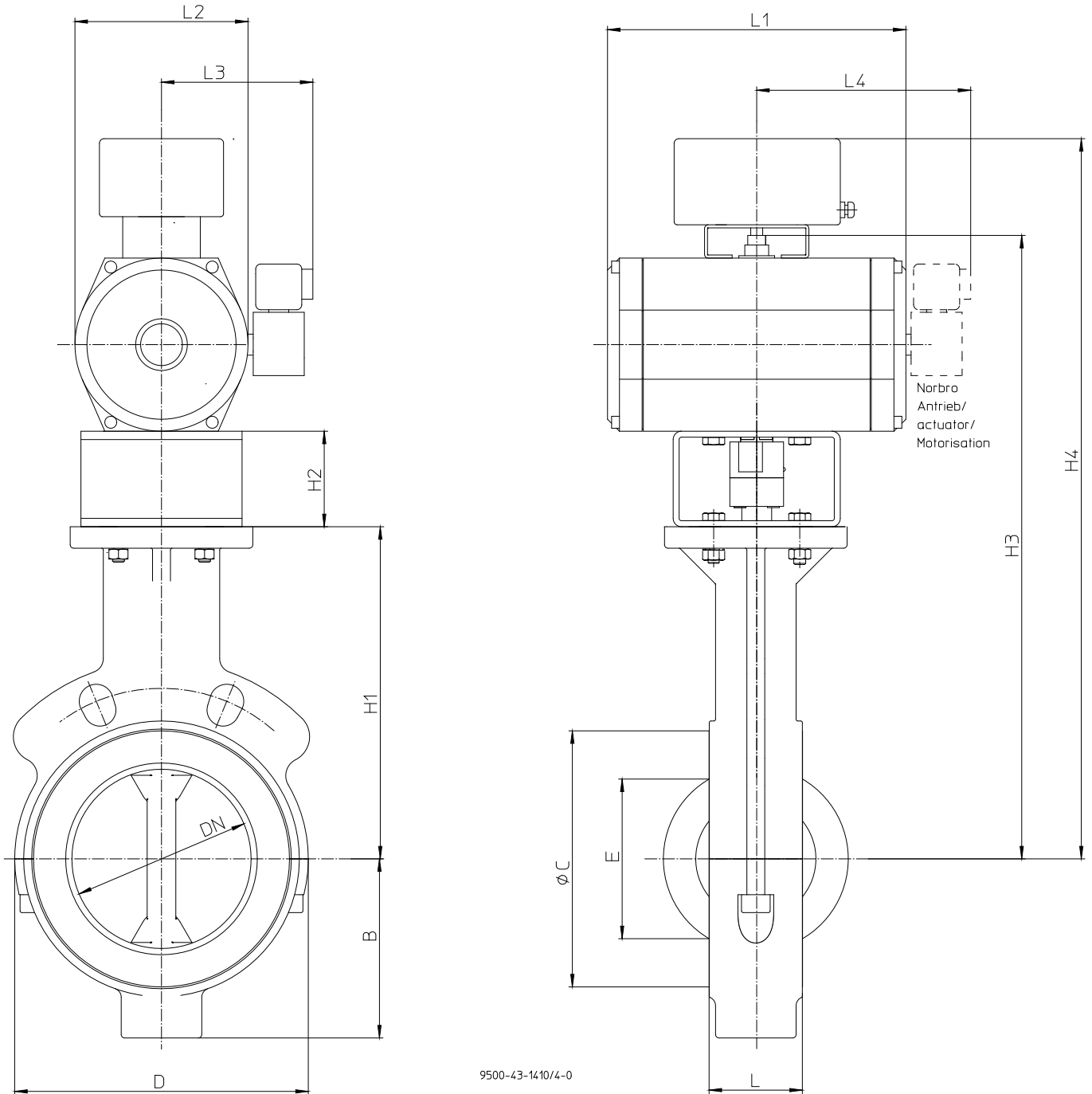
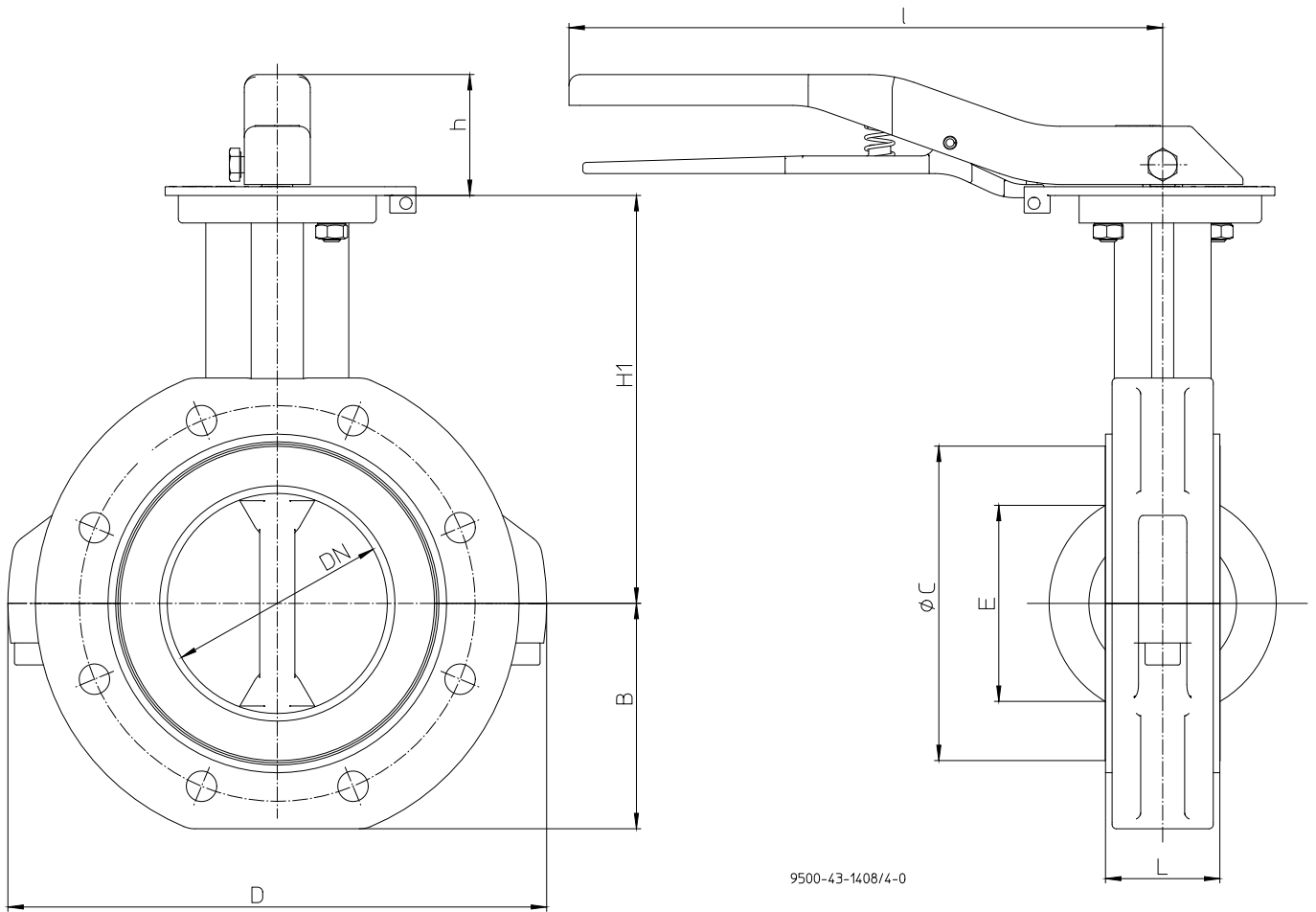

Table NKSP-C

DN		H1	B	L	D	ØC	E	ISO 5211	H2	H3	H4	L1	L2	L3	L4	
[mm]	[inch]	[mm]														
50	2"	130	56	43	153	85	31	F07	60							
65	2½"	146	67	46	173	106	48									
80	3"	165	84	46	210	122	63									
100	4"	185	100	52	245	143	90									
125	5"	202	110	56	272	166	118									
150	6"	217	125	56	295	193	137									
200	8"	245	158	60	364	251	189	F10	80							
250	10"	270	190	68	431	301	239									
300	12"	308	225	78	511	349	290									
350	14"	330	256	92	571	414	328	F12	80							
400	16"	365	292	102	643	460	377									
450	18"	From DN 350 (14") Lug-style body NKL-C with through holes						F14	80							
500	20"															
600	24"							F16	100							
700	28"															
750	30"							F25	200							
800	32"															
900	36"															
1000	40"							F30	200							

See manufacturer's information on the dimensions for the actuator.

10.10 Dimensional drawing NKL-C with hand lever



DN		H1	h	B	l	L	D	øC	E
[mm]	[inch]	[mm]							
50	2"	130	46	58	230	33	104	85	31
65	2½"	146	46	65	230	43	128	106	48
80	3"	165	46	88	230	46	144	122	63
100	4"	185	55	102	270	46	164	143	90
125	5"	202	55	116	270	52	194	166	118
150	6"	217	55	127	325	56	220	193	137
200	8"	245	55	160	349	56	274	251	189
250	10"	Only with worm gear							
300	12"								
350	14"								
400	16"								
450	18"								
500	20"								
600	24"								
700	28"								
750	30"								
800	32"								
900	36"								
1000	40"								

10.11 Dimensional drawing NKL-C with worm gear

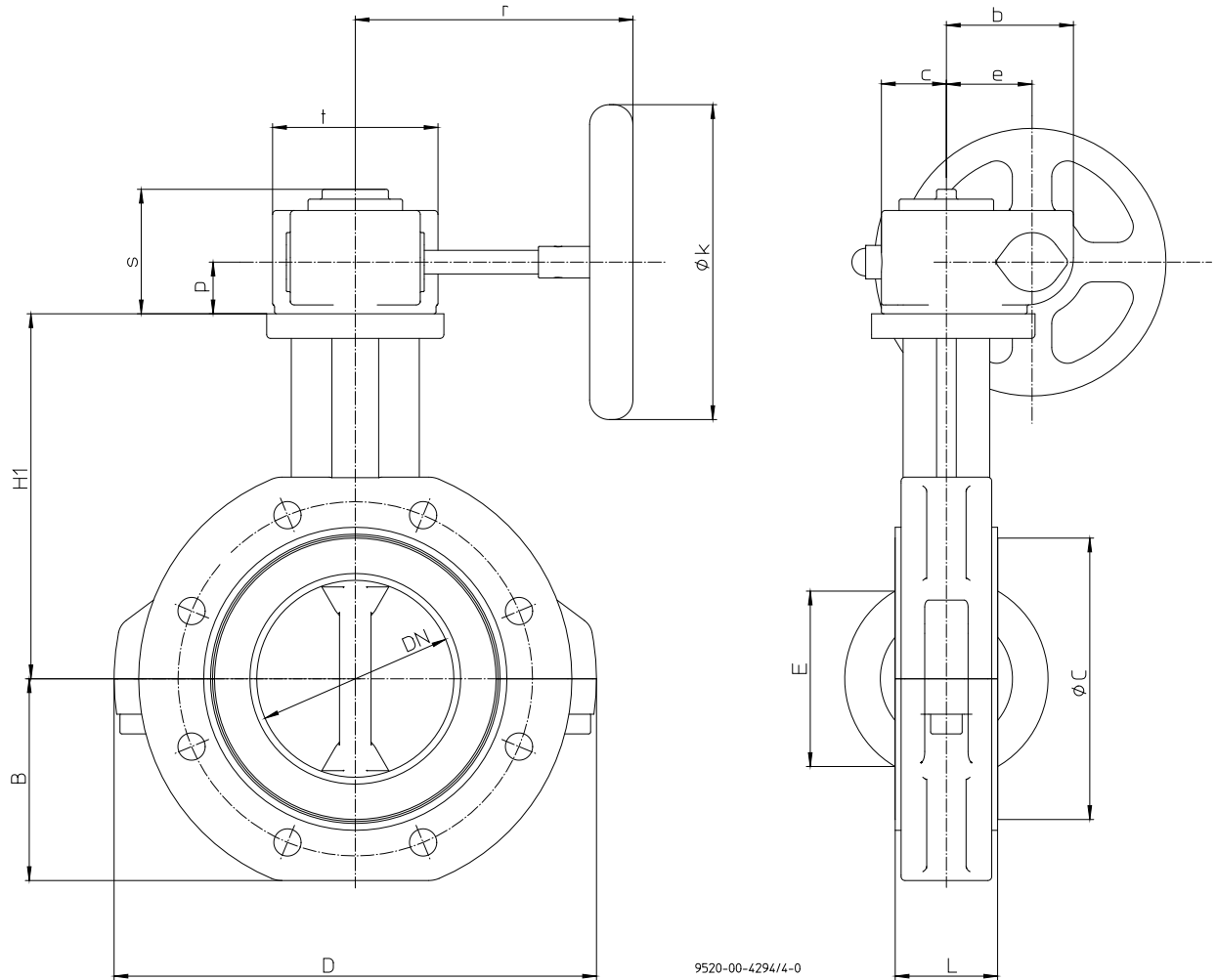

DN		H1	B	L	D	ØC	E	p	Øk	r	s	t	c	e	b
[mm]	[inch]	[mm]													
50	2"	130	58	43	153	85	31	28,5	125	128	64	84	45,7	43,5	67,5
65	2½"	146	65	46	173	106	48	28,5	125	128	64	84	45,7	43,5	67,5
80	3"	165	88	46	210	122	63	28,5	125	128	64	84	45,7	43,5	67,5
100	4"	185	102	52	245	143	90	28,5	125	128	64	84	45,7	43,5	67,5
125	5"	202	116	56	272	166	118	28,5	125	128	64	84	45,7	43,5	67,5
150	6"	217	127	56	295	193	137	34	200	215	75	112	55	52,5	81,5
200	8"	245	160	60	364	251	189	34	200	215	75	112	55	52,5	81,5
250	10"	270	193	68	431	301	239	34	200	215	75	112	55	52,5	81,5
300	12"	308	227	78	511	349	290	42,5	250	265,5	90,5	135	72,5	68,8	115
350	14"	330	256	92	571	414	328	42,5	250	265,5	90,5	135	72,5	68,8	115
400	16"	365	292	102	643	460	377	42,5	250	265,5	90,5	135	72,5	68,8	115
450	18"	400	311	114	684	515	417	45	300	289	97	156	83	84	123
500	20"	435	340	127	745	570	477	45	300	289	97	156	83	84	123
600	24"	510	398	154	863	672	560	54,5	400	389	128	282	140	137,5	186
700	28"	581	581	154	990	787	665	54,5	400	389	128	282	140	137,5	186
750	30"	608	608	154	1040	851	716	54,5	500	408	128	282	140	137,5	186
800	32"	630	630	154	1110	894	767	54,5	600	424	128	282	140	137,5	186
900	36"	684	684	154	1232	1016	860	54,5	600	424	128	282	140	137,5	186
1000	40"	771	771	154	1345	1101	970	54,5	400	436	128	282	140	137,5	186

10.12 Dimensional drawing NKLP-C

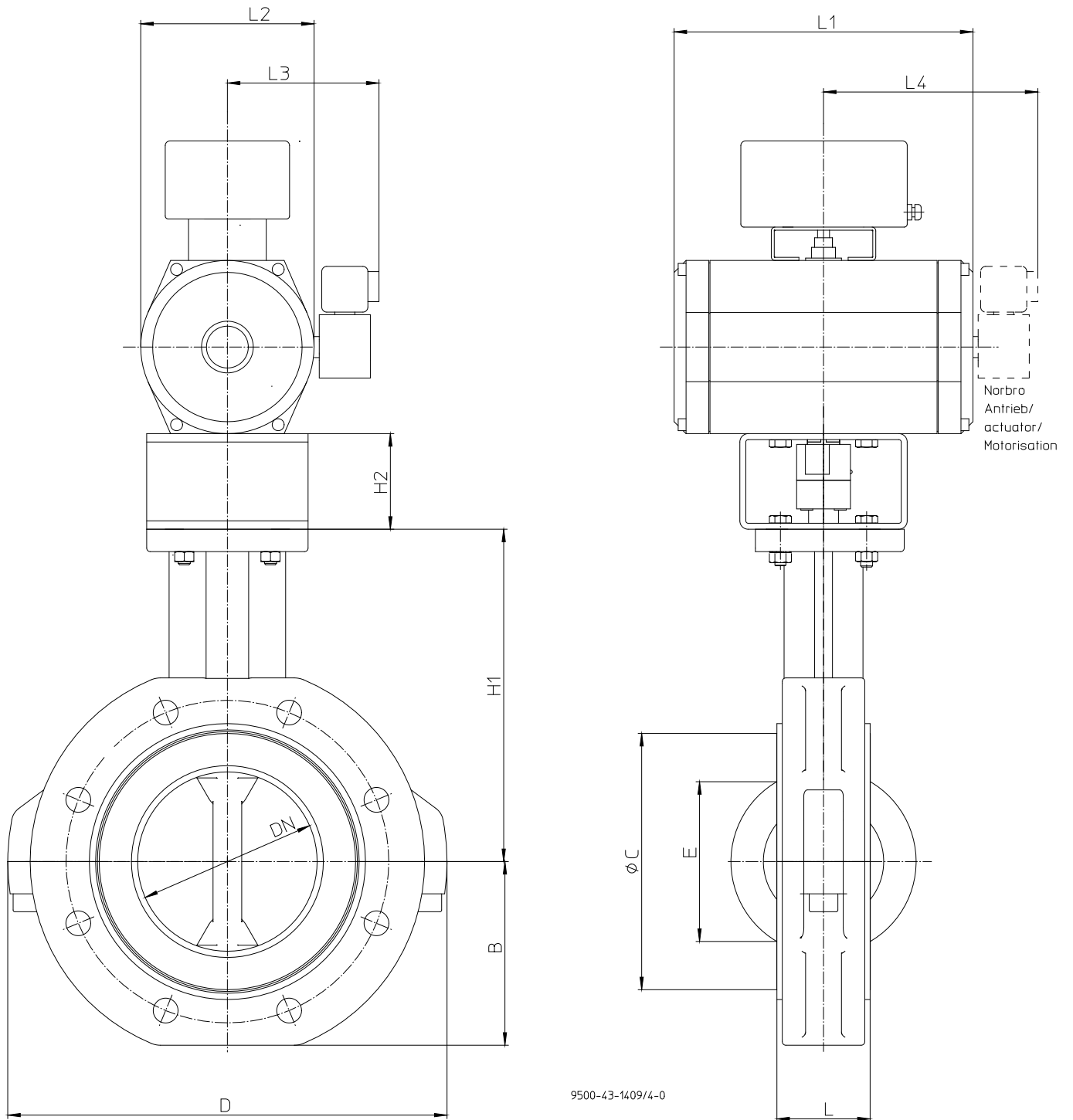

Table NKLP-C/F

DN		H1	B	L	D	ØC	E	ISO 5211	H2	H3	H4	L1	L2	L3	L4	
[mm]	[inch]	[mm]														
50	2"	130	58	43	153	85	31	F07	60							
65	2½"	146	65	46	173	106	48									
80	3"	165	88	46	210	122	63									
100	4"	185	102	52	245	143	90									
125	5"	202	116	56	272	166	118									
150	6"	217	127	56	295	193	137									
200	8"	245	160	60	364	251	189	F10	80							
250	10"	270	193	68	431	301	239									
300	12"	308	227	78	511	349	290									
350	14"	330	256	92	571	414	328	F12	80							
400	16"	365	292	102	643	460	377									
450	18"	400	311	114	684	515	417	F14	80							
500	20"	435	340	127	745	570	477									
600	24"	510	398	154	863	672	560	F16	100							
700	28"	581	581	154	990	787	665									
750	30"	608	608	154	1040	851	716									
800	32"	630	630	154	1110	894	767	F25	200							
900	36"	684	684	154	1232	1016	860									
1000	40"	771	771	154	1345	1101	970	F30	200							

See manufacturer's information on the dimensions for the actuator.

ChemValve-Schmid AG
Duennernstrasse 540
CH-4716 Welschenrohr
www.chemvalve-schmid.com

CE Konformitätserklärung nach EN ISO//IEC 17050
Declaration of Conformity according to EN ISO//IEC 17050

Produkt <i>Product</i>	PTFE-Absperrklappe <i>PTFE Lined Butterfly Valve</i>		
Bauart <i>Design</i>	Absperr- und Regelklappe <i>Shut-off and control butterfly valve</i>		
Baureihe <i>Serie</i>	NKL-C..., NKS-C...		
Nennweite <i>Size</i>	DN 50 bis DN 1000, <i>DN 50 to DN 1000,</i>	2" bis 40" <i>2" to 40"</i>	
Seriennummer <i>Series number</i>	ab/from 29.12.2009		
EU-Richtlinie <i>EU-Directive</i>	97/23/EG Druckgeräterichtlinie 2006/42/EG ¹⁾ Maschinenrichtlinie	97/23/EC Pressure Equipment Directive 2006/42/EC ¹⁾ Machinery Directive	
Angewandte Technische Spezifikation <i>Applied Technical Specification</i>	DIN EN 593 AD 2000 DIN EN ISO 12100		
Überwachungsverfahren <i>Surveillance Procedure</i>	97/23/EG Zertifizierungsstelle für Druckgeräte der TÜV Süd Industrie Service GmbH Notified Body 0036		
Konformitätsbewertungs- verfahren 97/23/EG <i>Conformity assessment procedure 97/23/EC</i>	Modul A1 / Modul B+C1		
Kennzeichnung <i>Marking</i>	97/23/EG	97/23/EC ¹⁾	CE 0036
	2006/42/EG ¹⁾	2006/42/EC ¹⁾	CE

Das Unternehmen ChemValve-Schmid AG bescheinigt hiermit, dass die o.a. Baureihen die grundsätzlichen Anforderungen der aufgeführten Richtlinien und Normen erfüllt.
ChemValve-Schmid AG confirms that the basic requirements of the above specified directives and standards have been fulfilled.

¹⁾ Alle Armaturen, mit Ausnahme der Armaturen mit Handbetätigung.
For all valves, with exceptions to valves with hand operation

Welschenrohr, 03.03.2011



B. Schmid
Geschäftsführer, Leiter Forschung & Entwicklung
Managing Director, Manager Research & Development



Ch. Schmid Schnyder
Leiter Qualitätsmanagement
Quality Manager



Industrie Service

Confirmation of Leakage Rate

ChemValve-Schmid AG
Valve Technology
Duennernstrasse 540
4716 Welschenrohr
Switzerland

We hereby confirm that the butterfly valves of the above company were tested applying the more stringent requirements outlined in VDI 2440 and approved. For details please see the relevant test report, order no.: 447034.

Product description:

- Butterfly Valves SwissValve CST

The product satisfies the following requirements:

- TA-Luft (measurement of leakage) as per VDI 2440, November 2000 edition
- Service conditions:
 - Number of cycles: 4000
 - Annealing at: 200°C
- Visual verification of the required contact pressure set forth in the operating manual
- Specified sealing system structure

The product meets the requirements defined for leakage measurement in line with Section 5.2.6.4 of the TA-Luft standard.

The certificate covers leakage measurement carried out on a stem seal as per VDI 2440 to verify tightness or observance of the specific leakage rate defined in the TA-Luft standard [$\lambda \leq 10^{-4}$ mbar \times l/(s \times m); $\Delta p = 10$ bar] and extended tests under the above operating conditions.

This certificate is valid to: November **2012**

Munich, 29th November 2010

TÜV SÜD Industrie Service GmbH
 Institute for Plastics

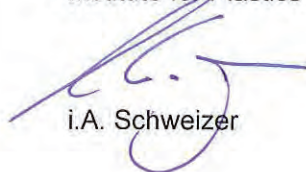
 i.A. Schweizer



Safety Information / **Declaration of No Objection** Concerning the Contamination of Richter-Pumps, -Valves and Components

1 SCOPE AND PURPOSE

Each entrepreneur (operator) carries the responsibility for the health and safety of his employees. This extends also to the personnel, who implements repairs with the operator or with the contractor.

Enclosed declaration is for the information of the contractor concerning the possible contamination of the pumps, valves and component sent in for repair. On the basis of this information for the contractor is it possible to meet the necessary preventive action during the execution of the repair.

Note: The same regulations apply to repairs **on-site**.

2 PREPARATION OF DISPATCH

Before the dispatch of the aggregates the operator must fill in the following declaration completely and attach it to the shipping documents. The shipping instructions indicated in the respective manual are to be considered, for example:

- Discharge of operational liquids
- remove filter inserts
- lock all openings hermetically
- proper packing
- Dispatch in suitable transport container
- Declaration of the contamination fixed **outside!!** on the packing

Declaration about the Contamination of Richter Pumps, -Valves and Components

The repair and/or maintenance of pumps, valves and components can only be implemented if a completely filled out declaration is available. If this is not the case, delay of the work will occur. If this declaration is not attached to the devices, which have to be repaired, the transmission can be rejected.

Every aggregate has to have it's own declaration.

This declaration may be filled out and signed only by authorized technical personnel of the operator.

Contractor/dep./institute : _____		Reason for transmitting <input checked="" type="checkbox"/> Please mark the applicable	
Street : _____		Repair: <input type="checkbox"/> subject to fee <input type="checkbox"/> Warranty	
Postcode, city: _____		Exchange: <input type="checkbox"/> subject to fee <input type="checkbox"/> Warranty	
Contact person: _____		<input type="checkbox"/> Exchange/ Replacement already initiated/received	
Phone : _____	Fax : _____	Return: <input type="checkbox"/> Leasing <input type="checkbox"/> Loan <input type="checkbox"/> for credit note	
End user : _____			
A. Details of Richter-product:		Failure description:	
Classification: _____		_____	
Article number: _____		Equipment: _____	
Serial number: _____		Application tool: _____	
_____		Application process: _____	
B. Condition of the Richter-product:		Contamination :	
	no ¹⁾ yes no		no ¹⁾ yes
Was it in operation ?	<input type="checkbox"/> <input type="checkbox"/> <input checked="" type="checkbox"/>	toxic	<input type="checkbox"/> <input type="checkbox"/>
Drained (product/operating supply item) ?	<input checked="" type="checkbox"/> <input type="checkbox"/> <input type="checkbox"/>	caustic	<input type="checkbox"/> <input type="checkbox"/>
All openings hermetically locked!	<input checked="" type="checkbox"/> <input type="checkbox"/> <input type="checkbox"/>	inflammable	<input type="checkbox"/> <input type="checkbox"/>
Cleaned ?	<input type="checkbox"/> <input type="checkbox"/> <input type="checkbox"/>	explosive ²⁾	<input type="checkbox"/> <input type="checkbox"/>
If yes, with which cleaning agent:		mikrobiological ²⁾	<input type="checkbox"/> <input type="checkbox"/>
and with which cleaning method:		radioactive ³⁾	<input type="checkbox"/> <input type="checkbox"/>
		other pollutant	<input type="checkbox"/> <input type="checkbox"/>
¹⁾ if "no", then forward to D. ← ²⁾ Aggregates, which are contaminated with microbiological or explosive substances, are only accepted with documented evidence of an approved cleaning. ³⁾ Aggregates, which are contaminated with radioactive substances, are not accepted in principle.		↓	
C. Details of the discharged materials (must be filled out imperatively)			
1. With which materials did the aggregate come into contact ? Trade name and/or chemical designation of operational funds and discharged materials, material properties, e.g. as per safety data sheet (e.g. toxic, inflammable, caustic)			
X Trade name: _____		Chemical designation: _____	
a) _____		_____	
b) _____		_____	
c) _____		_____	
d) _____		_____	
2. Are the materials specified above harmful to health ?		no yes	←
		<input type="checkbox"/> <input type="checkbox"/>	
3. Dangerous decomposition products during thermal load ?		<input type="checkbox"/> <input type="checkbox"/>	
If yes, which ones ?			

D. Mandatory declaration: We assure that the data in this explanation are truthful and complete and as a signatory I am able to form an opinion about this. We are aware that we are responsible towards the contractor for damages, which results from incomplete and incorrect data. We commit ourselves to exempt the contractor from claims for damages of thirds resulting from incomplete or incorrect data. We are aware that we are directly responsible towards thirds, irrespective of this declaration, which belongs in particularly to the employees of the contractor consigned with the handling repair of the product.

Name of the authorized person (in block letters): _____

_____ Date

_____ Signature

Company stamp

FAX**Fax No. ()****Pages (incl. cover sheet) ()****To:**

()

Richter Chemie-Technik GmbH
Otto-Schott-Straße 2
D-47906 KempenTelefon +49 (0) 21 52/146-0
Telefax +49 (0) 21 52/146-190richter-info@richter-ct.com
www.richter-ct.comContact person:
()Reference:
()Extension:
- ()E-Mail Address:
()Date:
()**Your order No.:** ()**Our Kom. No.:** ()**Serial No.:** ()

Dear Sirs,

The compliance with laws for the industrial safety obligates all commercial enterprises to protect their employees and/or humans and environment against harmful effects while handling dangerous materials.

The laws are such as: the Health and Safety at Work Act (ArbStättV), the Ordinance on Harzadous Substances (GefStoffV, BIOSTOFFV), the procedures for the prevention of accidents as well as regulations to environmental protection, e.g. the Waste Management Law (AbfG) and the Water Resources Act (WHG)

An inspection/repair of Richter products and parts will only take place, if the attached explanation is filled out correctly and completely by authorized and qualified technical personnel and is available.

In principle, radioactively loaded devices sent in, are not accepted.

Despite careful draining and cleaning of the devices, safety precautions should be necessary however, the essential information must be given.

The enclosed declaration of no objection is part of the inspection/repair order. Even if this certificate is available, we reserve the right to reject the acceptance of this order for other reasons.

Best regards
RICHTER CHEMIE-TECHNIK GMBHEnclosures

()