

Richter bellows-sealed shut-off and control valves

– manually actuated –

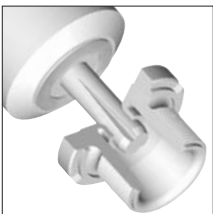
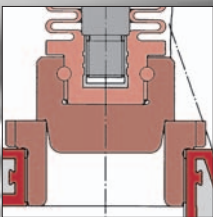
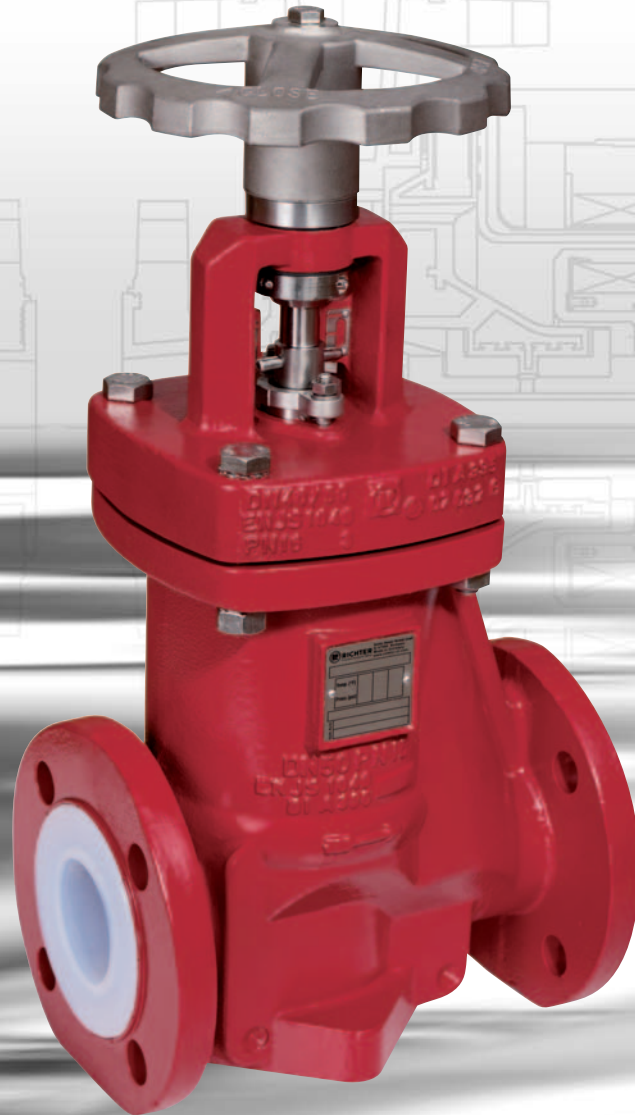

Lining pure PFA, optionally antistatic

Bellows sealing,
safety stuffing box

Heavy-duty bellows
- for permeating media
- up to 16 bar (235 psi) and
180 °C (360 °F)



RICHTER
Process Pumps & Valves



Bellows-sealed shut-off and control valves

Fields of application

As a shut-off valve, the HV with on/off plug is preferably used where a ball or butterfly valve, for example, cannot be deployed owing to the requirement for hermetic tightness: In conjunction with the standard safety stuffing box, the valve complies with the German Clean Air Code ("TA Luft").

Equipped with an equal percentage or linear control plug, the HVR can perform a genuine control function.

The body, seat and bellows can be replaced and varied independently, permitting optimum adaptation to the operating conditions in question and low-cost maintenance.

Operating range

- -60 to +180 °C (-75 to +360 °F) operating temperature
- 0.1 mbar (0.01 psi) vacuum up to 16 bar (235 psi) operating pressure

Design

Sealless bellows-sealed globe control and shut-off valve. Lined with fluoroplastic. Fitted with safety stuffing box as standard. Also available as a remote-controlled globe control valve, pneumatic or electric actuation (RSS series).

Control characteristics to DIN EN 60534

Equal percentage, linear, on-off. Rangeability 1:25 or 1:100 with V-control plug for k_v 0.01-1.20

Product features

- k_{vs} values from 0.01 to 155 m³/h (0.012 to 180 USgpm) in carefully graduated performance steps (table page 3)

Type codes, wetted materials

- Shut-off valve HV/...
- Control valve HVR/...

Lining:

- PFA (perfluoroalkoxy) .../F
- Antistatic PFA-L .../F-L
- Highly permeation-resistant PFA-P .../F-P

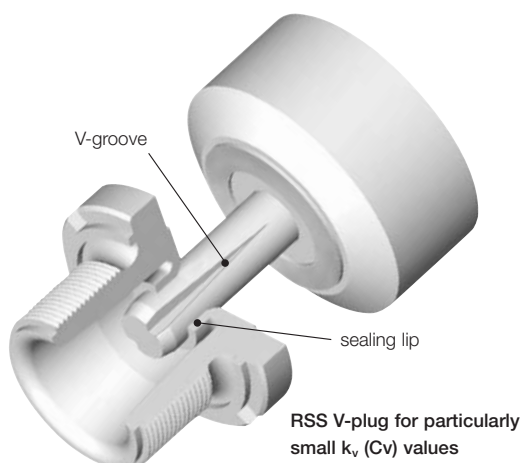

- ① **Thermoplastic lining made of pure PFA**
 - Universal chemical resistance
 - High permeation resistance
 - Guaranteed lining thickness 5-6 mm (at DN 15 and 20: 3.5-4 mm)
 - Vacuum-proof anchoring
 - Optimum quality assurance due to translucent lining material
 - Optionally also antistatic (PFA-L) and highly permeation-resistant (PFA-P) lining
- ② **One-piece pressure-bearing body of ductile cast iron EN-JS 1049/ASTM A395**
 - Cast steel 1.0619 on request
 - Absorbs system and pipe forces
 - Heating jackets on request
- ③ **PTFE bellows**

protect valve stem against corrosion and hermetically seal product chamber from atmosphere. Standard PTFE bellows up to 10 bar (145 psi) operating pressure.

Options:

 - **Heavy-duty PTFE bellows** for highly permeating media, pressures up to 16 bar (235 psi) and high temperatures, see illustration on page 3.
 - **Hastelloy® bellows** for special cases, e.g. extreme permeation and pressure/temperature conditions
- ④ **Safety stuffing box**
 - Adjustable from outside as a standard feature
 - Valve design complies with German Clean Air Code "TA Luft"
- ⑤ **Leak monitor connection**

as an option, especially for critical media
- ⑥ **Exchangeable valve plug**
 - Pure TFM-PTFE, without fillers
 - Screwed to bellows without play and secured by means of a PTFE cord
 - k_{v100}/C_v value can be changed by replacing seat/plug
 - Special V-control plug made of TFM-PTFE for minimum k_v values from 0.01 m³/h (C_v 0.012)
 - Special U-plug if there is risk of cavitation
- ⑦ **Exchangeable seat**

made of pure TFM-PTFE, without fillers
- ⑧ **External corrosion protection**

Body epoxy-coated. Stuffing box, hand-wheel, screws/nuts made of stainless steel.

k_{vs} Cv-values, components

Dimensions and weights for HV and HVR

Face-to-face lengths ISO 5752 series 1 (DIN EN 558-1 series 1)*, flanges ISO 7005-2/PN16 (DIN EN 1092-2)*

Face-to-face lengths ANSI/ISA 75.08.01 Cl. 150+300, flanges ASME (ANSI) B16.5 Cl. 150+300 RF

DN (mm) (inch)	D		H		L		L Cl.150		L Cl.300		Weight approx. kg	
	(mm)	(inch)	(mm)	(inch)	(mm)	(inch)	(mm)	(inch)	(mm)	(inch)		
15	1/2 ^{***}	100	3.94	263	10.35	130	5,12	130	5.12 ^{***}	-	-	7
20	3/4 ^{***}	100	3.94	273	10.35	130	5,12	130	5.12 ^{***}	-	-	7
25	1 ^{***}	95	3.74	301	11.85	160	6,3	184	7.24	197	7.75	12
40	1 1/2 ^{***}	160	6.3	364	14.33	200	7,87	222	8.7	235	9.25	17
50	2 ^{***}	160	6.3	372	14.65	230	9,05	254	10	267	10.51	20
65	2 1/2 ^{***}	190	7.48	372	14.65	290	11,42	***	***	-	-	22
80	3 ^{***}	230	9.05	519	20.43	310	12,2	298	11.73	-	-	49
100	4 ^{***}	350	13.78	529	20.83	350	13,78	352	13.78	-	-	55

* formerly DIN 3202/F1, 2532/33

** DN 1/2": flanges with tapped bore

*** not to ANSI/ISA

HV Flow rates for series with on-off plug

DN (mm) (inch)	max. seat Ø (mm)	k_{v100} (m ³ /h)	Cv (USgpm)
15	1/2"	5	7
20	3/4"	5	7
25	1"	13	15.2
40	1 1/2"	30	35
50	2"	45	52.4
65	2 1/2"	45	52.4
80	3"	111	129.3
100	4"	155	180.6

Components and materials

Item	Designation	Material
100	Body	Ductile cast iron EN-JS 1049 (ASTM A395)/PFA*
106	Cover	Ductile cast iron EN-JS 1049 (ASTM A395)/PFA*
204	Plug	TFM-PTFE
205	Seat	TFM-PTFE
206	Bellows	TFM-PTFE, optionally Hastelloy®
210	Hand wheel	1.4401 (Stainless steel)
300	Plain bearing	PTFE/carbon
302	Guide ring	PTFE/carbon
402	Packing ring	PTFE/carbon
405	Thrust ring	1.4401 (Stainless steel)
500	Ring	1.4305 (Stainless steel)
503	Packing gland follower	1.4401 (Stainless steel)
522	Round cord	PTFE
523	Travel indicator	1.4401 (Stainless steel)
855	Stem	Stainless steel
917/1	Screw-in pipe connector**	Stainless steel, optionally hex. head screw plug
939/2	Spring-type pin	1.4310 (Stainless steel)

* Optionally also antistatic (PFA-L) and highly permeation-resistant (PFA-P) lining

** only with option "leak monitor connection"

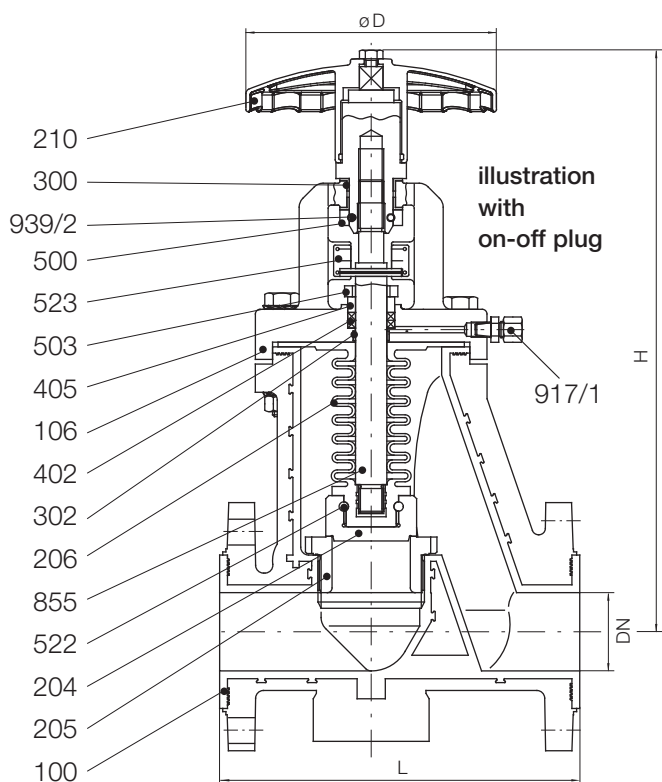

Special designs

Version for "biotechnology/pure media"

for the pharmaceutical and fine chemical industries, electronic chemicals, fermentation etc., suitable for CIP and SIP!

- Anti-adhesive lining, seamlessly integrated seat
- One-piece PTFE bellows/plug design without cavities, DN 15+20 with standard bellows
- "Pure media production processes" and FDA certificate on request

Version for highly permeating media (e.g. chlorine)

A special bush made of Hastelloy® C, for example, protects the cover flange in the valve stem area against corrosive attack by permeating media. The valve stem made of Hastelloy® C, for example, remains moveable. Thick-walled pure PFA, optionally: highly permeation-resistant PFA-P.

Presented by:

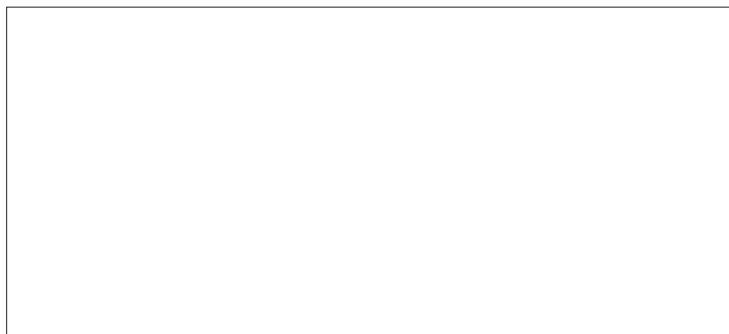

Richter Chemie-Technik GmbH

Otto-Schott-Str. 2, D-47906 Kempen, Germany
Tel. +49 (0) 21 52/146-0, Fax +49 (0) 21 52/146-190
www.richter-ct.com, richter-info@idexcorp.com