

## SERIES KSEA/F Safety Relief Valves with ASME - certification spring-loaded



### WARNING

All RICHTER products are designed and manufactured to the highest standards of workmanship and design and, as of the printing of this document, they meet all applicable industry standards.

These valves are available with components of various materials and should be used only as directed in the product catalog. Installation and maintenance must be performed by qualified personnel.

- ◆ **Do not operate the valves beyond the stated pressure and temperature ratings!**
- ◆ **Misuse, improper installation and improper maintenance may result in personal injury and/or property damage!**
- ◆ **Use only valve components consistent with the performance requirements and as directed in these instructions.**

- ◆ **Failure to heed these operating instructions may void the warranty!**
- ◆ **If a valve exhibits any indication of leakage, do not operate! Isolate the valve and either repair or replace the valve.**

### Keep for future use!

This operating manual must be strictly observed before transport, installation, operation and maintenance etc. in order to avoid damage to persons or property.

Subject to change without notice.

Reproduction is generally permitted with indication of the source and as long as the copyright notice is not obscured or defaced.

Copyright © Richter Chemie-Technik GmbH

## List of Contents

<b>List of Contents .....</b>	<b>2</b>	<b>7 Operation.....</b>	<b>12</b>
<b>Relevant documents.....</b>	<b>2</b>	7.1 Initial commissioning.....	12
<b>1 Technical data.....</b>	<b>3</b>	7.2 Shutdown.....	12
1.1 Name plate and body identification .....	3	7.3 Recommissioning.....	12
1.2 Tightening torques.....	4	7.4 Improper operations and their consequences .....	12
1.3 Pressure/temperature diagram .....	4	<b>8 Malfunctions.....</b>	<b>13</b>
<b>2 Safety.....</b>	<b>5</b>	<b>9 Maintenance.....</b>	<b>13</b>
2.1 Intended use.....	5	9.1 Screw connections.....	14
2.2 For the customer / operator.....	5	9.2 Cleaning.....	14
2.3 Improper operation .....	5	9.3 Modification of the safety valve.....	14
<b>3 Safety notes for applications in potentially explosive areas based on the Directive 94/9/ EC (Atex 95) .....</b>	<b>6</b>	9.4 Adjustment of the test pressure .....	14
3.1 Intended use.....	6	9.5 Important notes on dismantling / installation .....	14
<b>4 Safety note for valves, certified to Clean Air Act (TA Luft) .....</b>	<b>7</b>	9.6 Replacement of components .....	14
<b>5 Transport and storage.....</b>	<b>7</b>	9.6.1 Dismantling of the plug .....	14
5.1 Transport securing for KSEA/F .....	7	9.6.2 Dismantling of the seat .....	15
5.2 Storage .....	7	9.6.3 Installation of the seat .....	15
5.3 Return consignments .....	8	9.6.4 Installation of the plug .....	15
5.4 Disposal.....	8	9.6.5 Installation of the thrust ring .....	15
<b>6 Installation.....</b>	<b>8</b>	9.7 Dismantling KSEA/F 100/150 .....	15
6.1 Sizing of the inlet line .....	8	9.7.1 Dismantling of the entire upper section / Removal of the seat and plug .....	15
6.2 Sizing of the outlet line .....	8	9.8 Assembly KSEA/F 100/150.....	16
6.2.1 Admissible back pressure .....	8	9.9 Tests .....	18
6.2.2 Drainage of condensate .....	9	9.9.1 Lift .....	18
6.2.3 Discharge conditions and reaction forces .....	9	9.9.2 Adjustment of set pressure .....	18
6.3 Valve connecting dimensions.....	9	9.9.3 Pressure setting .....	18
6.4 Flange caps and gaskets .....	9	9.9.4 Set pressure tolerances .....	18
6.5 Direction of flow and installation.....	9	9.9.5 Seat tightness test .....	18
6.6 Grounding.....	10	9.9.6 Seat tightness test with air .....	19
6.7 Installation .....	10	9.9.7 Leakage test with air .....	19
6.8 Blocking screw (option) .....	10	9.9.8 Acceptance criteria (air) .....	19
6.9 Signal transmitter (Option) .....	10	9.9.9 Seat tightness test with water .....	19
6.10 Design for highly permeating media (Option) .....	11	9.9.10 Leakage test with water .....	19
6.11 Shortened or no lifting lever (Option) .....	11	9.9.11 Acceptance criteria (water) .....	19
6.12 Travel stop (Option).....	11	9.9.12 Back pressure test .....	19
		<b>10 Drawings.....</b>	<b>20</b>
		10.1 Legend .....	20
		10.2 Sectional drawing KSEA/F .....	21
		10.3 Views.....	22
		10.4 Dimensional drawing.....	23

## Relevant documents

- ◆ Data/Inspection sheet
- ◆ Declaration of conformity
- ◆ Form for Safety Information Concerning the Contamination QM 0912-16-2001\_en

### On request :

- ◆ Pressure spring table
- ◆ Bellows operating ranges, TIS 0587-02-0006

# 1 Technical data

## Manufacturer:

Richter Chemie-Technik GmbH  
 Otto-Schott-Str. 2  
 D-47906 Kempen, Germany  
 Telephone : +49 (0) 2152 146-0  
 Fax: +49 (0) 2152 146-190  
 E-Mail: [richter-info@richter-ct.com](mailto:richter-info@richter-ct.com)  
 Internet: <http://www.richter-ct.com>

## Designation:

Series KSEA/F, direct-acting, spring-loaded bellows safety relief valve with angle-type valve body, according to

ASME Code Section VIII, Division 1

Marking: UV and NB stamp.

Certified for vapours/gases **and** liquids.

Tightness tested to API 527.

Flange connecting dimensions: ASME B16.5 class 150

Certified to German Clean Air Act (TA Luft)

## Materials :

Shell material: Ductile cast iron SA-395 to ASME Code Section VIII, Division 1

Lining material: PFA, PTFE  
 on request conductive design

## Set pressure :

Valve size KSEA/F	Set pressure [psi]	Set pressure [bar]
1" / 2"	3,62 – 188	0,25 – 13
2" / 3"	1,45 – 188	0,1 – 13
3" / 4"	1,45 – 145	0,1 – 10
4" / 6"	1,45 – 145	0,1 – 10

No UV stamped valve shall be set below 15 psi (1,034 barg).

**Temperature range:** – 20 °F to + 356 °F  
 (– 29 °C to + 180 °C)

See pressure-temperature diagram in [Section 1.3](#)

## Valve size inlet/outlet (in.):

KSEA/F 1" / 2", 2" / 3", 3" / 4", 4" / 6"

## Weight :

KSEA/F 1" / 2" approx. 33 lbs (15 kg)  
 KSEA/F 2" / 3" approx. 55 lbs (25 kg)  
 KSEA/F 3" / 4" approx. 88 lbs (40 kg)  
 KSEA/F 4" / 6" approx. 187 lbs (85 kg)

## Installation position :

A direction arrow on the body indicates the direction of flow. See [Section 6.5](#).

## Dimensions and individual parts:

See sectional drawing in [Section 10](#) and options in [Section 6.8 to 6.12](#).

## Options :

- ◆ Travel stop for restricted lift
- ◆ Blocking screw
- ◆ Signal transmitter
- ◆ Design for heavily permeating media (e.g. chlorine)
- ◆ Shorted lifting lever
- ◆ Without lifting lever

See also [Section 6.8 to 6.12](#).

## 1.1 Name plate and body identification

The stainless steel identification plate is permanently riveted to the body.

If the customer mounts his identification, it must be ensured that the valve corresponds to the application.

### Examples name plate:

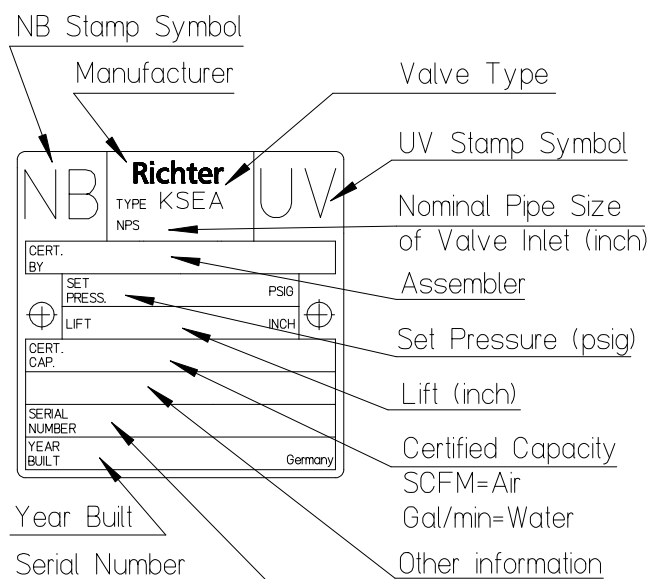

9500-43-1306/4-0

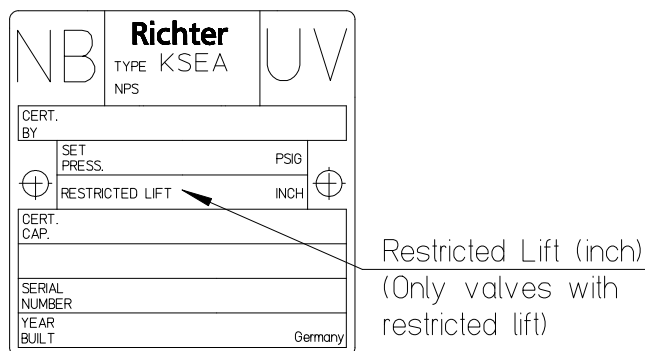

9500-43-1307/4-0

**Body identification:**

The shell bears the following information:

- ◆ valve size (Inlet x Outlet, inch)
- ◆ pressure rating class
- ◆ shell material
- ◆ manufacturer's identification
- ◆ cast number/foundry identification
- ◆ arrow for direction of flow

**1.2 Tightening torques**

All screws greased, tighten in diametrically opposite sequence!

The tightening torques for pipe screws and body screws mentioned must not be exceeded. For an exception, see **Section 8** flange connection valve / pipe is leaking.

The following tightening torques are recommended:

**Pipe screws**, flanges to ASME B16.5, class 150

Flange nom. diameter		Screws [ASME]	Torque	
[mm]	[inch]		[in-lbs]	[Nm]
25	1	4 x 1/2"	70	8
50	2	4 x 5/8"	220	25
80	3	4 x 5/8"	400	45
100	4	8 x 5/8"	310	35
150	6	8 x 3/4"	710	80

**Screws body / inlet nozzle**

Valve type	Screws	Torque	
		[in-lbs]	[Nm]
KSEA/F 1 1/2"	4 x 3/8"-16	106	12
KSEA/F 2 2/3"	4 x 1/2"-13	354	25
KSEA/F 3 3/4"	8 x 3/8"-16	177	20
KSEA/F 4 7/6"	8 x 3/8"-11	354	25

**Hex. socket screws 914/1 of the bellows gasket**

Valve type	Screws	Torque	
		[in-lbs]	[Nm]
KSEA/F 1 1/2"	4 x 5/16"-18	89	10
KSEA/F 2 2/3"	4 x 5/16"-18	106	12
KSEA/F 3 3/4"	4 x 5/16"-18	106	12
KSEA/F 4 7/6"	8 x 5/16"-18	89	10

**1.3 Pressure/temperature diagram**



When used in the minus temperature range, the regulations applicable in the country in question must be observed.

Max. permissible pressure/temperature for the body.

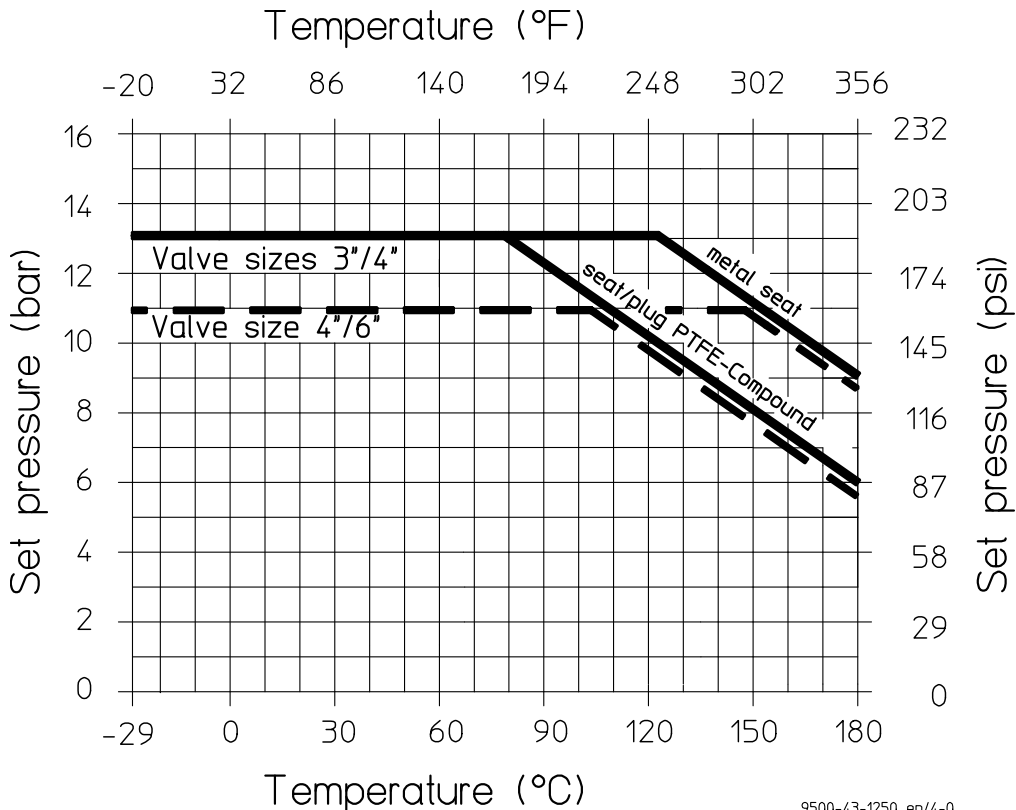

9500-43-1250\_en/4-0

## 2 Safety

This operating manual contains fundamental information which is to be observed during installation, operation and maintenance.

**It must therefore be read before installation and commissioning!**

For valves which are used in potentially explosive areas, see **Section 3**.

Installation and operation are to be performed by qualified staff.

The area of responsibility, authority and supervision of the staff must be regulated by the customer.



**General hazard symbol !**  
Peoples may be put at risk.



**Safety symbol !** The valve and its function may be put at risk if this safety symbol is not observed..

It is imperative to observe warnings and signs attached directly to the valve and they are to be kept fully legible.



**Failure to heed and follow these notes on safety may cause damages to persons and property!**

**The manufacturer is not responsible for and hereby disclaims all damages resulting from a failure to observe adequate safety precautions in connection with the operation, maintenance and repair of the valves!**

For example, non-observance may involve the following hazards:

- ◆ Failure of important functions of the valve/plant.
- ◆ Risk to people from electric, mechanical and chemical effects.
- ◆ Risk to the environment through leaks of hazardous substances.

### 2.1 Intended use

Richter safety relief valves of the series KSEA/F are Pressure Relief Devices in accordance with the ASME Boiler & Pressure Vessel Code Section VIII, Division 1. They protect the pressure equipment if the admissible pressure limit is exceeded.

KSEA/F are only intended for vertical installation.

The valves are suitable for vapours, gases and liquids. They have a corrosion-resistant plastic lining.

Safety valves are intended to prevent inadmissible excessive pressures, e.g. in piping systems, pressure vessel plants and boilers. Risks to people, the environment and plants are thus avoided.

**Solids** can lead to increased wear, leaks, damage to sealing surfaces or to a reduction in the service life of the valve.



The safety valves have been set at the works to the desired test pressure, tested and lead-sealed.

The precise operating conditions of the safety valve selected are documented in the **Inspection sheet**. It also contains the performance features such as the certified coefficient of discharge, the flow cross area, set pressure, opening pressure, reseating pressure and materials.

If the valve is intended for other operating data, the operator must carefully examine whether the design of the valve, accessories and materials are suitable for the new application.

### 2.2 For the customer / operator

If a safety valve is used, the operator must ensure that

- ◆ hot or cold valve parts are protected by the customer against being touched  
- ◆ the valve has been properly installed in the pipe system
- ◆ the operating conditions stipulated in the data sheet are not exceeded in continuous operating mode.

This is not the manufacturer's responsibility.

Loads caused by earthquakes were not allowed for in the design.

Fire protection to DIN EN ISO 10497 is not possible (plastic lining and plastic components).

### 2.3 Improper operation

Permitted operation of these valves is limited to the intended purpose, as shown in **Section 2.1** of these operating instructions.



Under no circumstances must the operating parameters specified on the identification plate and in the pressure-temperature diagram be exceeded.

**Failure to operate the valves within the operating parameters voids the warranty!**

See also improper operation and their consequences in **Section 7.4**.

### 3 Safety notes for applications in potentially explosive areas based on the Directive 94/9/ EC (Atex 95)

The valves are intended for use in a potentially explosive area and are therefore subject to the conformity assessment procedure of the directive 94/9/EC (ATEX).

As part of this conformity assessment, an ignition hazard analysis to EN 13463-1 to satisfy the fundamental safety and health requirements was conducted with the following result:

- ◆ **The valves do not have any ignition source of their own.**
- ◆ **The valves are not covered by the scope of application of the ATEX directive and therefore do not need to be identified accordingly.**
- ◆ **The valves may be used in a potentially explosive area.**

It is imperative to observe the individual points of intended use for application in a potentially explosive area.

#### 3.1 Intended use

**Improper operation, even for brief periods, may result in serious damage to the valve.**

**In connection with explosion protection, potential sources of ignition (overheating, electrostatic and induced charges, mechanical and electric sparks) may result from these improper operation; their occurrence can only be prevented by adhering to the intended use.**

Furthermore, reference is made in this connection to the Directive 95/C332/06 (ATEX 118a) which contains the minimum regulations for improving the occupational health and safety of the workers who may be at risk from an explosive atmosphere.

A difference is made between two cases for the use of chargeable liquids (conductivity  $<10^{-8}$  S/m):

#### 1. Chargeable liquid and non-conductive lining



Charges can occur on the lining surface. As a result, this can produce discharges inside the valve. However, these discharges cannot cause ignitions if the valve is completely filled with medium.

If the valve is not completely filled with medium, e.g. during evacuation and filling, the formation of an explosive atmosphere must be prevented, e.g. by superimposing a layer of nitrogen.

It is recommended to wait 1 hour before removing the valve from the plant in order to permit the elimination of static peak charges.

This means that, to safely prevent ignitions, the valve must be completely filled with medium at all times or else a potentially explosive atmosphere must be excluded by superimposing a layer of inert gas.

#### 2. Chargeable liquid and conductive lining

No hazardous charges can occur as charges are discharged direct via the lining and shell (surface resistance  $<10^9$  Ohm, leakage resistance  $<10^6$  Ohm).

The following special feature applies to the series with bellows (HV, HVR, BAV, KSE, KSEA, GU, GUT, PA):

The bellows are not offered in a conductive version, i.e. the restrictions under point 1. apply.

Richter optionally offers conductive metallic bellows for the series HV.

**Static discharges of non-conductive linings are only produced through the interaction with a non-conductive medium and are therefore the responsibility of the plant operator.**

**Static discharges are not sources of ignition which stem from the valves themselves!**

- The temperature of the medium must not exceed the temperature of the corresponding temperature class or the maximum admissible medium temperature as per the operating manual.
- If the valve is heated (e.g. heating jacket), it must be ensured that the temperature classes prescribed in the Annex are observed.
- To achieve safe and reliable operation, it must be ensured in inspections at regular intervals that the valve is properly serviced and kept in technically perfect order.
- Increased wear to the valve can be expected with the conveyance of liquids containing abrasive constituents. The inspection intervals are to be reduced compared with the usual times.
- Actuators and electric peripherals, such as temperature, pressure and flow sensors etc., must comply with the valid safety requirements and explosion protection provisions.
- The valve must be grounded.  
This can be achieved in the simplest way via the pipe screws using tooth lock washers. Otherwise grounding must be ensured by other action, e.g. cable bridges.
- Plastic-lined valves must not be operated with carbon disulphide.

## 4 Safety note for valves, certified to Clean Air Act (TA Luft)

On request, this valve can be supplied compliant with the German Clean Air Code.

Certificate / Manufacturer Declaration Validity is dependent on the operating instructions being read and observed.

In particular, servicing must be conducted at regular intervals, and the bolted connections relevant for tightness must be inspected and retightened if necessary.

## 5 Transport and storage



It is imperative, for all transport work, to observe generally accepted engineering practice and the accident prevention regulations.



The safety valve is supplied with flange caps. Do not remove them until just before installation. They protect the plastic surfaces against dirt and mechanical damage.

Handle the goods being transported with care. During transport the valve must be protected against impacts and collisions.

**Never transport the valve using the lifting lever 238.**

See sectional drawing and details in [Section 10](#).

Transport the valve upright in a box or on a pallet on a soft surface and deposit gently on flat ground.

Directly after receipt of the goods, the consignment must be checked for completeness and any in-transit damage.

Do not damage epoxy-coating.

With the KSEA/F 4"/6" valves, a ring bolt **908/1** is screwed into the lifting cap which facilitates transport. It must be ensured that the ring bolt lies on the axis of the discharge flange so that equilibrium is guaranteed when the valve is lifted. See [View W](#) in [Section 10.4](#).



Safety valves with set pressures  $\leq 7,25$  psi (0,5 bar) are fitted at the works with a transport fastening strap which holds the stem in the axial direction

It pre-vents damage to the shut-off element as a result of the stem shaking during transport. See [Fig. 1](#) and [Section 6.7](#).

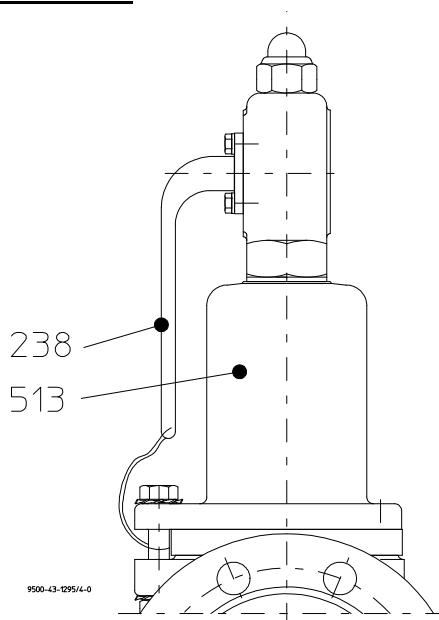

**Fig. 2**

### 5.1 Transport securing for KSEA/F

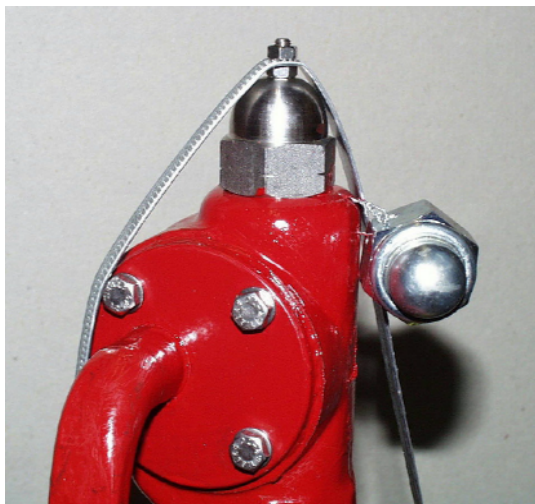

**Fig. 1**

Remove the safety wire between the lifting lever **238** and one connection screw of the lifting cap **513** /body **100** prior to commissioning. See [Section 6.6](#) and [Fig. 2](#).

### 5.2 Storage

If the valve is not installed immediately after delivery, it must be put into proper storage.

The product should be stored in a dry and vibration-free, well ventilated room at as constant a temperature as possible. Elastomers are to be protected against UV light.

In general, a storage period of 10 years should not be exceeded.

Store the valve in an upright position and secure it from falling over! In case of prolonged storage individual packing with a desiccant may be necessary. Pay attention to local site.

## 5.3 Return consignments



Valves which have conveyed aggressive or toxic media must be well rinsed and cleaned before being returned to the manufacturer's works.



Observe appropriate safety precautions when cleaning the valves of toxic or aggressive media.

Appropriate safety clothing and equipment should be worn at all times when working with toxic media!

It is **imperative** to enclose a **safety information sheet / general safety certificate** on the field of application with the return consignment.

Pre-printed forms are enclosed with the installation and operating manual.

Safety precautions and decontamination measures are to be mentioned.

## 5.4 Disposal

Parts of the valve may be contaminated with medium which is detrimental to health and the environment and therefore cleaning is not sufficient.



Risk of personal injury or damage to the environment due to the medium!

- ◆ Wear protective clothing when work is performed on the valve.
- ◆ Prior to the disposal of the valve:
  - Collect any medium, etc. which has escaped and dispose of it in accordance with the local regulations.
  - Neutralise any medium residues in the valve.
- ◆ Separate valve materials (plastics, metals, etc.) and dispose of them in accordance with the local regulations.

## 6 Installation

**The installation conditions to the ASME Code Section VIII, Division 1, Appendix M must be observed. They are major preconditions for the safe operation of the valve.**

- ◆ Examine valve for in-transit damage, damaged globe shut-off or control valves must not be installed.
- ◆ Before installation the valve and the connecting pipe must be carefully cleaned to remove any dirt, especially hard foreign matter.
- ◆ During installation, pay attention to the correct tightening torque, aligned pipes and tension-free assembly.

### 6.1 Sizing of the inlet line



The admissible pressure loss in the inlet line must not exceed 3% of the set pressure of the safety valve.

The determination of the pressure loss relates to the maximum flow of the valve at 110% of the set pressure and 110% of the certified coefficient of discharge.

- ◆ An excessive pressure loss at the inlet of the safety valve can cause rapid opening and reseating of the valve or chattering.
- ◆ Chattering results in a reduction in the discharge capacity and may cause an inadmissible rise in pressure in the system and damage to the seat sealing surfaces.
- ◆ **The inlet line must never be smaller than the nominal diameter of the safety valve inlet.**

- ◆ Lay supply lines as short as possible.
- ◆ Install, if at all possible, the valve directly on the container to be protected.
- ◆ At least chamfer the container nozzle in the inlet or even better provide with a radius.
- ◆ An inlet nozzle with a tapered design has the best shape in terms of flow.

### 6.2 Sizing of the outlet line



Outlet lines are to be sized so that reliable functioning of the valve is ensured under all expected operating conditions.

The medium is to be discharged so that there is no risk to people and the environment. The statutory provisions (e.g. accident prevention regulations, and the equivalents of the German Pollution Control Act or the German Clean Air Code) as well as local regulations (works standards) are to be observed.

- ◆ There must be no possibility of the safety valves becoming ineffective due to shut-off elements.

#### 6.2.1 Admissible back pressure

- ◆ **The outlet line must never be smaller than the nominal diameter of the safety valve outlet.**
- ◆ The admissible back pressure in the valve outlet must not be exceeded in order to prevent destruction of the bellows or a reduction in the discharge capacity.

### 6.2.2 Drainage of condensate

Lay horizontal pipes with a gradient away from the valve so that the liquid medium cannot accumulate in the valve body and that, in the case of gases, no condensate collects in the body.

If outlet lines are laid with a geodetic level difference (e.g. for vapours or gases with a 90° vertical upright pipe bend out of the valve), the bend must not be located directly downstream of the valve.

A horizontal pipe section with a gradient must firstly be installed downstream of the valve.

A draining facility must be provided at the lowest point in the pipe. This opening for the drainage of condensate must be lower than the flow chamber of the body.

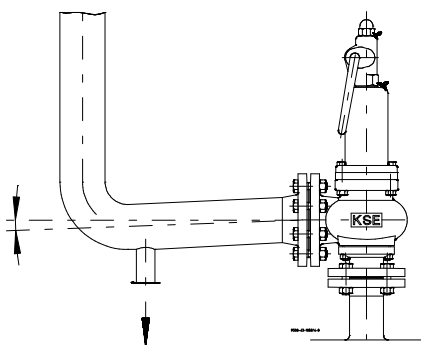

Fig. 4

Lines for the drainage of condensate are to have adequate cross sections. They are to be laid with a gradient and must ensure safe drainage of the medium.

### 6.2.3 Discharge conditions and reaction forces

#### At low temperatures:



Outlet lines must be protected against freezing. This applies in particular if gas cooling as a result of expansion is to be expected or lines are laid outdoors.

#### With crystallising media:



In the case of media which tend to crystallise, solidify or stick, appropriate action must be taken to ensure that the solidification process cannot take place in the inlet or outlet lines or in the body (e.g. installed rupture disc, insulation, heating).

#### With gassing media:



In the case of gassing or vaporising liquids, adequately dimensioned flashtraps must be located in the direct vicinity of the valve.

#### Reaction forces during discharge:



The pipes and their holders are to be dimensioned so that their weight forces and the reaction forces and thermal loads produced during discharge can be safely absorbed.

### 6.3 Valve connecting dimensions

The safety valves are to be equipped with flange connections to ASME B16.5 Class 150.

The dimensions of the flange connections and the main dimensions are contained in the drawing in [Section 10.5](#).

### 6.4 Flange caps and gaskets

Contamination of or damage to the sealing surfaces is best avoided if the protective caps remain on the flanges until just before installation.

We recommend the installation of gaskets so that the sealing surfaces are not damaged by the mating flanges.

If plastic sealing surfaces can be damaged, PTFE-lined seals with a metal inlay should be used. This may be the case with counter-flanges made of metal or enamel.

PTFE-lined seals are available as special accessories from the Richter range.

### 6.5 Direction of flow and installation



When the valve is being installed, the direction of flow must be observed; it is indicated by an arrow on the valve body.

- ◆ A mix-up of the inlet and outlet will result in the valve becoming ineffective and the bellows may be destroyed.
- ◆ Always install the safety valve with the stem in a vertical position.

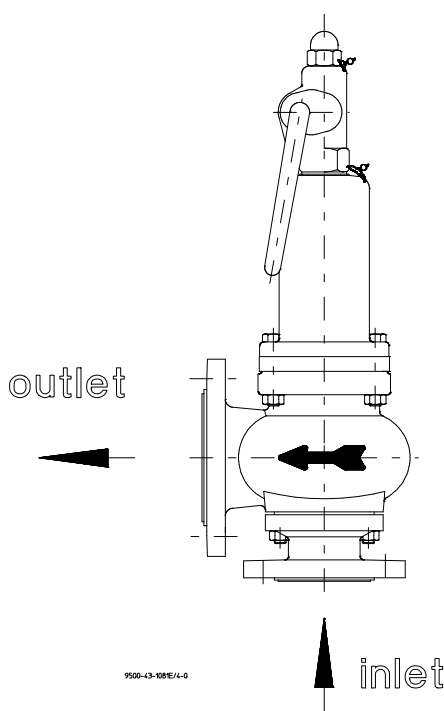

Fig. 5

## 6.6 Grounding

The valve must be grounded. The simplest solution is to use tooth lock washers which are placed under one pipe bolt of each flange.

At the customer's request a setscrew M6 with a hex. nut and washer will be provided at each flange as an additional grounding connection.

Otherwise grounding must be ensured by different measures e.g. a cable link.

## 6.7 Installation

- ◆ The plant components to be protected are to be cleaned thoroughly prior to installation of the valve.
- ◆ Solids jeopardise the soft-sealing, high-precision surfaces of the seat and plug and permanent leaks could arise.
- ◆ The safety valve must be installed so that no inadmissible mechanical or thermal stresses are transmitted from the attached pipes to the body.
- ◆ Changes in length of the pipes due to temperature are to be allowed for, e.g. through the installation of expansion joints.
- Remove the flange covers.
- Before installation (valves with set pressures  $\leq 7,25$  psi /  $\leq 0,5$  bar), remove metallic transport securing strip and cap nut for securing the valve during transport. Screw on attached lead-sealed cap nut **927/1**. See **Section 5.1**.
- Remove the securing wire between the bonnet **513** and the lifting lever **238**.
- Position and align the safety valve and any additional gaskets. Then tighten the pipe screws with a torque wrench in diametrically opposite sequence.  
For tightening torques, see **Section 1.2**.

## 6.8 Blocking screw (option)



During the pressure test of the plant the safety valve cannot discharge through the blocking screw.

- ◆ This blocking screw may only be used for this purpose. **Always remove again immediately.**
- ◆ Damage to the valve could occur and pressure protection is then no longer provided.
- The lead-sealed cap nut **927/1** is replaced during the pressure test of the plant by a cap nut **927/1B** with an additional tapped bore for the blocking screw **901/4**.
- In the KSEA/F 4"/6" the lead-sealed hex. screw **901/3** is replaced by a threaded rod **918/1** with a prevailing torque type hex. nut **929/2**.  
The cap nut/blocking screw or the threaded rod/hex. nut are supplied separately.  
See also the details in **Fig. 6**.

- After the pressure test **remove** the cap nut **927/1B** with the blocking screw **901/4** or threaded rod **918/1** with the hex. nut **929/2** again.



- Screw in the cap nut **927/1** or, in the case of the KSEA/F 4"/6", the hex. screw **901/4** with the bore for the lead seal again and have them **lead-sealed again**. See also **Fig. 6**.

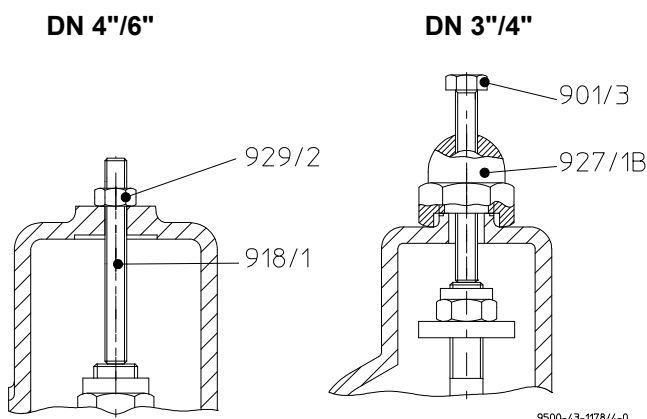

9500-43-1178/4-0

**Fig. 6**

Legend see **Section 10.1**.

## 6.9 Signal transmitter (Option)

On request, an signal transmitter is available for remote monitoring.

- Glue in stem extension **805** (e.g. Loctite 638) and secure with a hex. nut **920/4**.
- The support, lower part, **542** is screwed on instead of the cap nut **927/1**.
- Insert the O-ring **400/3**.
- Mount support, upper part, **541**.
- Screw in signal transmitter **859**; after adjustment, counter with hex. nut.
- Secure support, upper part, with setscrew **904/1**.
- Design with blocking screw:  
Insert the O-ring **400/2**, screw in hex. screw **901/4** and lead-seal. See **Fig. 9**.

**DN 1 1/2", 2 1/3", 3 1/4"**

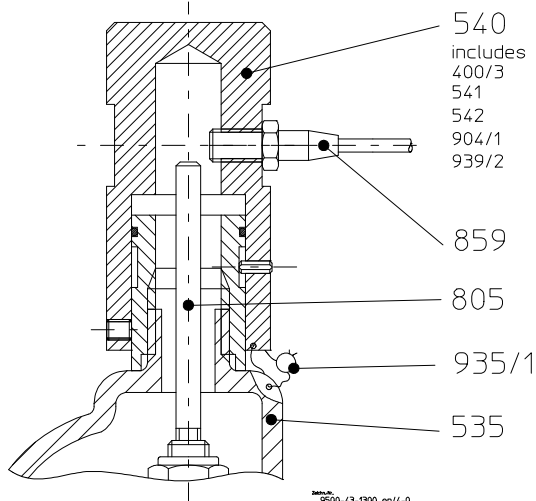

9500-43-1300\_en/4-0

**Fig. 7**

**DN 4"/6"**

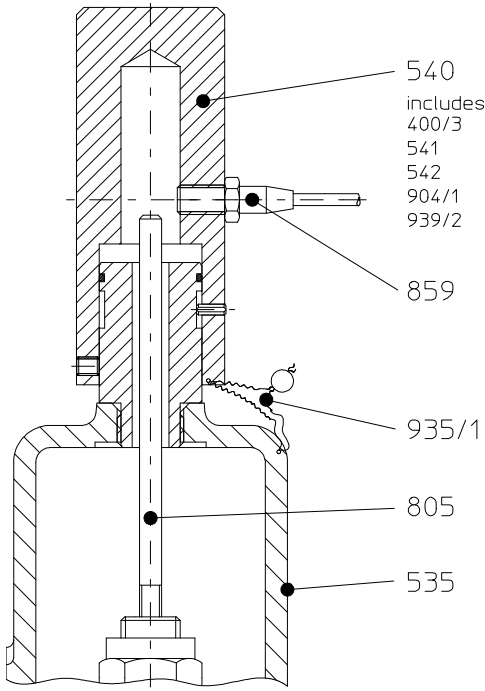

9500-43-1301\_en/4-0

**Fig. 8**

With size 4"/6" the bellows guide **860** made of PTFE protects the stem guide **306**. See **Fig. 11**. With the other sizes the stem guide is made of HC-4.

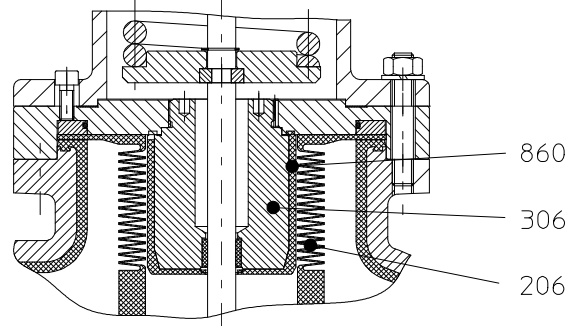

Legend see **Section 10.1**.

**Fig. 11**

**Design signal transmitter for blocking screw**

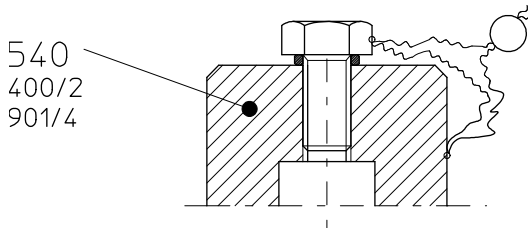

**Fig. 9**

Legend see **Section 10.1**.

**6.11 Shortened or no lifting lever (Option)**

In order to exclude unauthorised activation, the lifting lever **238** can be shortened; a lever is supplied loose. See **Fig. 12**.

the valve can be without a lifting lever; the locking plate **539** is not bored. See **Fig. 13**.

**Fig. 12**

**Fig. 13**

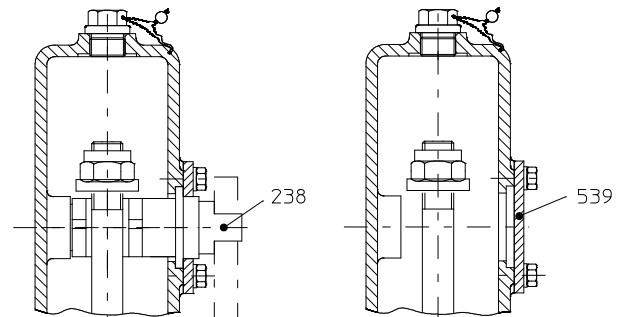

9500-43-1077/L-0

Legend see **Section 10.1**

**6.10 Design for highly permeating media (Option)**

The stem **802**, insert sleeve **308**, parallel pin **561/1**, thrust ring **405**, bearing guide **305** and adjusting screw **538** are made of HC-4.

In addition, with the sizes 3"/4" and 4"/6" the adjusting screw **538** has a guide bush **307/2** made of PTFE. See **Fig. 10**.

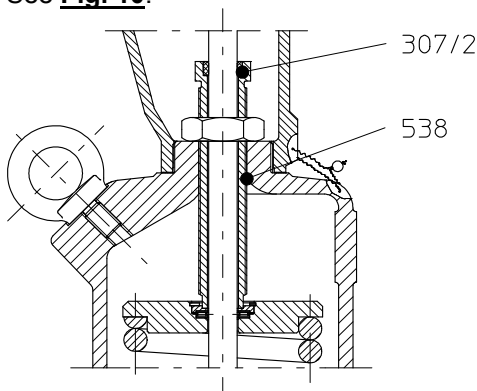

**Fig. 10**

**6.12 Travel stop (Option)**

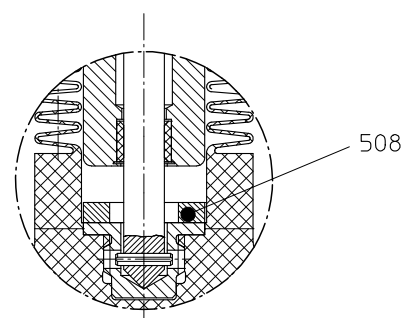

**Fig. 14**

Legend see **Section 10.1**.

## 7 Operation

### 7.1 Initial commissioning

Normally, the valves have been tested for leaks with air or water.



Unless otherwise agreed, there could be residual amounts of water in the flow section of the valve; this could result in a possible reaction with the medium.

**The max. operating pressure of the plant must generally be less than the reseating pressure of the safety valve.**

Following the initial loading of the valve with operating pressure and temperature, the torques of all connecting bolts must be checked.

See [Section 1.2](#).

### 7.2 Shutdown

- ◆ The local regulations are to be observed when dismantling the valve.



In every case ensure that the pipeline and the vessel have been relieved of pressure and emptied.

- ◆ Appropriate measures are to be taken to prevent human life and the environment being endangered by a leak of aggressive or toxic media.
  - ◆ If a dismantled valve is to be returned to the workshop or to the manufacturer, it has to be thoroughly cleaned.
- See also [Section 5.4](#).

### 7.3 Recommissioning

When recommissioning the valve, make sure that **all the appropriate steps** as described in [Section 6.1 to 6.6](#) and [Section 7.1](#) are repeated.

### 7.4 Improper operations and their consequences

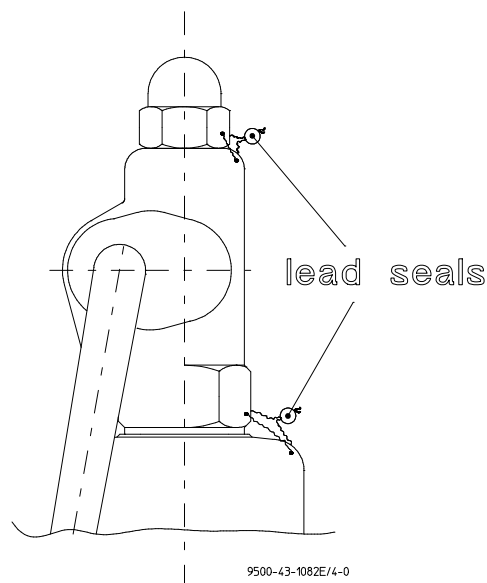

**Fig. 15**

- ◆ Under no circumstances must the operating parameters specified on the identification plate be exceeded.
- ◆ **Failure to operate the valves within the operating parameters voids the warranty!**
- ◆ The test pressure, checked by the manufacturer, an approved authority or the supervisory company responsible is secured against unauthorised adjustment by a lead seal.
- ◆ A broken lead seal must be replaced without delay. This can either be done by the manufacturer, the approved authority or the supervisory company responsible.



**It is emphasised that in the case of the operating company adding the lead seal itself, it automatically assumes full responsibility for any operational hazard and resulting damage.**

- ◆ The travel set at the manufacturer's works ensures reliable operation of the valve. It is forbidden to arbitrarily alter the travel or to totally block the valve.
- ◆ During operation of the valve, no hard foreign matter may be found between the seat and the plug of the valve.
- ◆ If foreign matter is deposited on the sealing surfaces during reseating of the valve, the valve is probably not tight. Damage may also occur to the plastic sealing surfaces.

## 8 Malfunctions

### ◆ Safety valve is leaking

Is there foreign matter between the seat and plug?

Is there any wear or damage to the seat or plug?

Have the nuts at the inlet nozzle been unevenly tightened?

Actuation of the lifting lever can help to regain the required sealing effect. If this does not succeed in stopping the leak, the sealing surface of the plug must either be reworked or the plug or seat must be replaced.

### ◆ The lift given in the test certificate is not achieved

Are the bellows impeded in their movement by external influences (e.g. foreign matter, solidified medium between the folds etc.)?

Has the insert sleeve **308** been screwed out of the thread of the bellows?

For measuring the valve lift, see **Section 9.7.1**.

If the required lift is still not attainable after elimination of the disorders, an examination at the manufacturer's is necessary.

### ◆ Medium is escaping at the bonnet

Have the hex. socket screws **914/1** not been tightened ?

If, after tightening the screws, tightness still cannot be restored, either the plastic lining or the bellows is damaged.

The cause of cracked bellows could have been, for example, an inadmissibly high back pressure during operation of the safety valve. Dismantle the safety valve and have it repaired.

### ◆ Flange connection leaking

Check the torque of the pipe screws with a torque wrench. If tightness is not achieved, the recommended torque (see **Section 1.2**) may be exceeded by 10%.

If it still proves impossible to stop the leak, then the lining is damaged. Dismantle the safety valve and check.

### ◆ The safety valve chatters during discharge

Do the inlet and outlet lines conform to the relevant regulations?

See also **Section 6.1 and 6.2**.

Is the valve oversized?

Valves which are too large can subsequently be adapted to the mass flow reducing the lift. To this end, the required lift is determined and a travel stop ring is mounted inside the valve.

## 9 Maintenance



Safety relief valves must be checked for operability at regular intervals according to the national regulations.

- ◆ The intervals for regular checks are to be laid down by the customer in line with the operating conditions.
- ◆ The lifting lever **238** allows the valves to be actuated from outside, they then open at the operating pressure available. For lifting, the pressure is to be at least 75% of the set pressure (ASME Code Section VIII, Division 1, UG-136(a)(3)).
- ◆ All repair work is to be performed by qualified personnel using the appropriate tools. Generally recognised practice in mechanical engineering is to be observed.
- ◆ For the arrangement, designation and item numbers of all parts of the valve, see **Section 10**.
- ◆ Spare parts are to be ordered with all the details in acc. with the valve identification.
- ◆ Only original spare parts may be installed.  
**Use of spare parts other than original spare parts voids the warranty!**

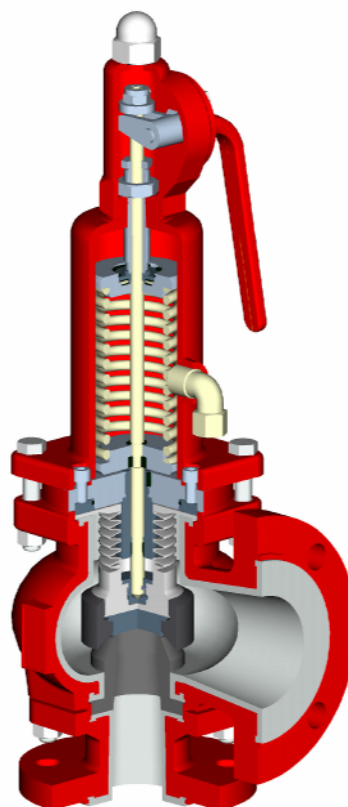

Fig. 16

## 9.1 Screw connections

- ◆ To prevent leaks, a regular check of the connection screws should be made in line with the operating requirements.  
For tightening torques, see [Section 1.2](#).
- ◆ To prevent screw connections from becoming loose in the event of pressure fluctuations or plant vibrations, we recommend the installation of expansion joints or pulsation dampers.

## 9.2 Cleaning



Prior to starting any repair work, the valve is to be thoroughly cleaned. Even if the valve has been properly emptied and rinsed, residual medium may still be found in the valve, e.g. between the lining and body or in the bonnet.

Plastic parts may absorb medium which gradually emerges from the material after cleaning.



Wear the prescribed protective clothing!

Safety valves which have been cleaned with water or other media must be dried before re-assembly of the parts and installation of the valve in the plant.

## 9.3 Modification of the safety valve

If modifications to the valve are required, the manufacturer must always be consulted.

**Examples:** Modification with changed test pressure, replacement of the spring or adaption to the mass flow by reducing the travel.

After approval by the manufacturer, these modifications can be performed either by the manufacturer or by the customer under the guidance of a technical supervisory agency or any other approval authority.

## 9.4 Adjustment of the test pressure

- Undo locking plate **539**, dismantle lifting lever **238** and unscrew the lifting cap **535**.
- Undo nut **920/3**.
- Adjust the spring tension with the adjusting screw **538** to the specified test pressure.
- Counter adjusting screw **538** with a hex. thin nut **920/3**, resp. with centering nut **555** (1"/2").
- Check test pressure.
- Screw on lifting cap **535** and tighten.
- Insert lifting lever **238**.
- Mount locking plate **539**.

- Have the valve lead-sealed.
- The data specified in the test certificates are to be observed.

## 9.5 Important notes on dismantling / installation

First relieve plug **204** and lift it off the seat.

- The seat and plug could otherwise be destroyed. Read the precise instructions in [Section 9.6](#).
- Then undo the screws between the body **100** and the inlet nozzle **122** or between the bonnet **513** and body **100**.
- ◆ Always replace the seat and plug **pairwise** and always rework them **completely**.
- ◆ Reworking of the seat and plug requires specialised knowledge of the material as well as special lapping wheels.
- ◆ It is therefore recommended to have this work carried out by the manufacturer.
- ◆ After dismantling, check all parts for wear and damage.
- ◆ Observe sectional drawings in [Section 10](#).

## 9.6 Replacement of components

### 9.6.1 Dismantling of the plug

- Undo locking plate **539**, dismantle lifting lever **238** and unscrew lifting cap **535**.
- Mark the position of the stem nut **534**.
- Unscrew the self-locking hex. nut **929/1** and stem nut **534** off the stem **802**.
- When undoing or tightening the hex. nut with the self-locking feature **929/1**, carefully hold the spindle tight with pliers to prevent it from turning.



**Do not turn the entire spindle 802!**

There is a risk that the insert sleeve **308** will be screwed out of the bellows **206** and the folds or the spring-type pin **939/1** will be damaged!

- Mount a suitable distance sleeve (not included in the scope of delivery) over the stem **802**.
- Screw the stem nut **534** against the distance sleeve. The plug **204** is lifted off the seat **205** and the closing force becomes ineffective.
- Loosen the bolts **901/1**, **936/1**, **936/2** and **920/2** (in the case of KSEA/F 4"/6" **902/2**, **934/1**, **936/1** and **920/2**) and lift the bonnet with internals completely off.
- Grip the bellows **206** in the reinforced section just above the lifting aid **237**. Unscrew the lifting aid off the bellows and remove the plug **204**.

### 9.6.2 Dismantling of the seat

- Remove bonnet **513** from the body **100**. See [Section 9.6.1](#).
- Dismantle inlet nozzle **122** from the body **100** and remove the seat **227**.

### 9.6.3 Installation of the seat

- Insert the new or reworked seat **205** at the bottom into the corresponding centring of the body **100**.
- Then insert the inlet nozzle **122** into the centring of the body **100**.  
The components must be smooth running, i.e. can be centred without any constraining forces.  
If necessary, the inlet nozzle is to be turned through 90°.
- First tighten the attachment nuts **920/1** hand-tight and then with a torque wrench evenly and in diametrically opposite sequence.



It is imperative to observe the prescribed torques for the connection body / inlet nozzle! See [Section 1.2](#).

### 9.6.4 Installation of the plug

- All parts are to be thoroughly cleaned before assembly.
- Centre the new or reworked plug **204** in the lifting aid **237** and screw hand-tight onto the bellows thread. **Counter the bellows 206 at the reinforced section.**
- Undo the hex. socket screws **914/1**. Centre the bonnet **513** with internals on the body **100**. Ensure that there is metallic contact between the body and the bonnet. Then tighten the screws **901/1**, **936/1**, **936/2** and **920/2** (on KSEA/F 4"/6" **902/1**, **934/1**, **936/1** and **920/2**).
- Tighten the hex. socket screws **914/1** for the bellows seal evenly in line with the tightening torques.
- Undo stem nut **534**.
- Remove distance sleeve.
- Screw stem nut **534** onto the stem **802** up to the marking. Then counter with the self-locking hex. nut **929/1**.
- When screwing on and countering the hex. nut with self-locking feature **929/1**, carefully hold the spindle tight with pliers to prevent it from turning.



**Do not turn the entire spindle 802!**  
There is a risk of the folds in the bellows **206** or the spring-type pin **939/1** being damaged!

- Screw on lifting cap **535** and mount lifting lever **238** with locking plate **539**.

### 9.6.5 Installation of the thrust ring

Make sure that the O-ring **400/1** is positioned completely inside the groove of the pressure ring **124** so that it is not damaged when the thrust ring is inserted into the thrust flange **117**.

If the O-ring **400/1** has been damaged by improper assembly, water may enter from outside into the valve mechanism.

The bellows and cause corrosion damage. A defective O-ring must be replaced before the valve is installed in the plant.

## 9.7 Dismantling KSEA/F 100/150



**Caution:** During dismantling of the entire KSEA/F, the nuts of the fitting between the body and the inlet nozzle must under no circumstances be undone – **Risk of accident!**

**The springs must firstly be completely relieved!**

### 9.7.1 Dismantling of the entire upper section / Removal of the seat and plug

- To remove the seat and plug undamaged, the plug **204** must be lifted off the seat **205**.
- Unscrew the cap nut **927/1** from the lifting cap **535** and remove the cap.
- Unscrew the hex. nut with self-locking feature **929/1** and the stem nut **534** off the spindle **802**.
- When loosening and unscrewing the hex. nut with self-locking feature **929/1**, carefully hold the spindle tight with pliers to prevent it from turning.



**Do not turn the entire spindle 802!**  
There is a risk of the folds in the bellows **206** or the spring-type pin **939/1** being damaged!

#### Lifting plug off the seat

- Mount a spacer sleeve (approx. 11.4" (35 mm) long) on the end of the spindle **802** and screw on a nut and counter it with another hex. nut. (Not included in scope of delivery).
- Grease the end surfaces of the spacer sleeve well so that these surfaces cannot "seize" when raising the adjusting screw **538**.

The spacer sleeve may also be replaced by hex. nuts. See [Fig. 17](#).



Fig. 17

- In order to lift the plug 204 off the seat 205, raise the entire spindle.
- Undo adjusting screw 538 and turn it out of the spring bonnet 513.
- When undoing the adjusting screw 538, hold the spindle with a wrench on the counter nut so that the bellows 206 or the spring-type pin 939/1 are not damaged. See Fig. 18.

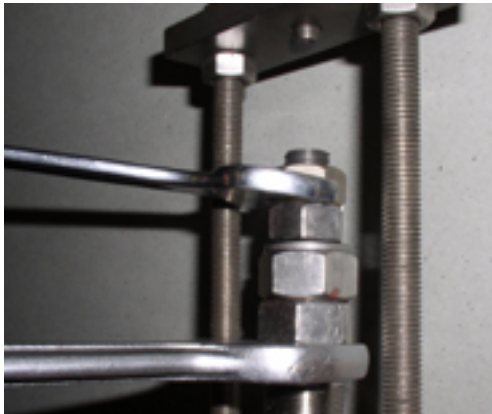

Fig. 18

- Unscrew hex. socket screw 914/1 off the pressure ring 124.
- Clean and grease the two threaded rods (approx. 6" (150 mm) long / 180° offset).
- Undo hex. nuts 920/2 to attach the spring bonnet 513 and thrust flange 117.
- Remove complete upper section.
- Press the bellows collar out of the guide of the thrust flanges and then screw the bellows 206 off the spindle 802.
- Assemble the entire upper section (without bellows) again with the body 100.
- Screw hex. nut onto the threaded rod (up to flange contact with spring bonnet 513).
- Screw hex. nuts onto both ends of the threaded rods and counter with more hex. nuts.
- Tighten adjusting screw 538 (turn into the spring bonnet 513) until the spacer sleeve is loose.

- Undo hex. nuts at the end of the spindle and also remove spacer sleeve.
- Undo adjusting screw 538 and screw it out of the spring bonnet 513.
- **The pressure spring 952/1 is only partially relieved in this situation.**
- In order to completely relieve the spring, the two nuts per threaded rod are evenly turned upwards until the spring bonnet is loose.



It is imperative to secure the threaded rods against turning (turning out of the body flange) with a wrench on the counter nut – **Risk of accident!**

See Fig. 19.

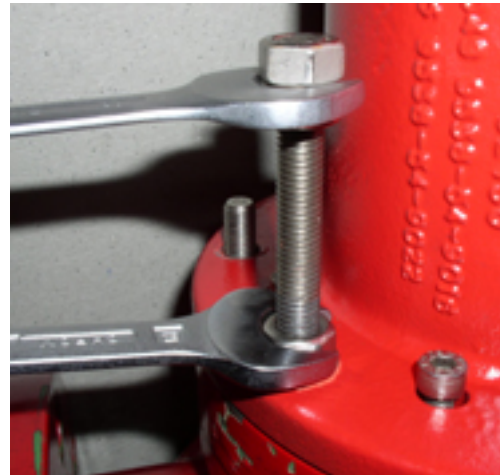

Fig. 19

- The KSEA/F can now be further dismantled. See relevant Sections in 9.4 to 9.6.

## 9.8 Assembly KSEA/F 100/150

- Assemble the complete upper section with its internals without the bellows 206, plug 204 and lifting aid 237.
- Grease the outside thread of the adjusting screw and the inside thread in the spring bonnet (for adjusting screw) well and, if difficult to screw, also spray with torsion spray.
- Mount a hex. nut on the free end of the spindle so that when the complete unit is raised the internals are held and they do not fall down. See Fig. 20.



Fig. 20

- Completely mount the lower valve section (body, seat, inlet nozzle). The pressure ring **124** is placed on the sealing strip of the body. See [Fig. 21](#).



Fig. 21

- Mount the complete upper section (without bellows **206**, plug **204** and lifting aid **237**) onto the valve body.
- Clean and grease the two threaded rods (approx. 6" (150 mm) lining / 180° offset).
- Tighten spring bonnet **513** with hex. nuts until they sit tightly on the body **100**. See [Fig. 18](#).
- The pressure spring **952/1** is now partially pre-tensioned. The view into the outlet flange shows the position of the spindle (distance between the insert sleeve **308** and stem guide **306**).

See [Fig. 22](#)

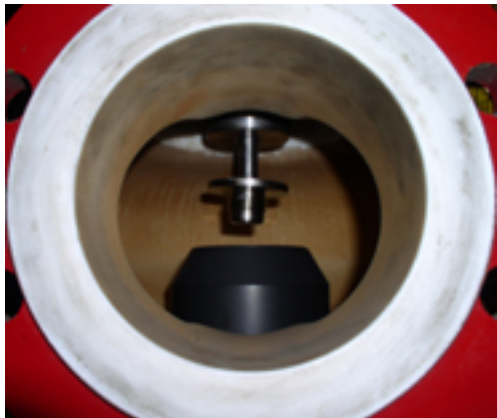

Fig. 22

- This must be raised further until the distance between the upper edge of the insert sleeve and the edge of the stem guide is approx. 5 mm.
- In order to raise the spindle **802** into this position, the adjusting screw **538** is now pre-tensioned approx. 1" (25 mm) (turned into the bonnet). Then mount a distance sleeve approx. 35 mm long (or hex. nuts with U-washer, see [Fig. 17](#)) onto the now free spindle end.
- Grease the end surfaces of the spacer sleeve well so that these surfaces cannot "seize".
- A hex. nut is screwed onto the spindle end and countered with another hex. nut. See [Fig. 17](#).

- Undo adjusting screw **538** (turn out of the spring bonnet **513**) until the distance between the upper edge of the insert sleeve and the edge of the stem guide is approx. 5 mm. See [Fig. 23](#).
- When undoing the adjusting screw **538**, hold the spindle **802** with a wrench on the counter nut to prevent it from turning so that the bellows **206** or the spring-type pin **939/1** are not damaged.

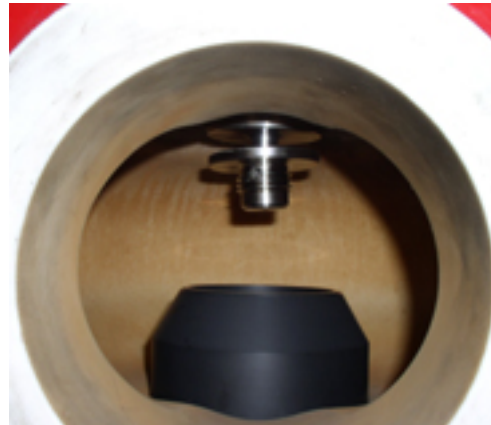

Fig. 23

- Undo the hex. nuts **920/1** (on the flange of the spring bonnet **513**) and lift off the entire upper section.
- Install pressure ring **124** in the thrust flange **117** (observe [Section 9.6.5](#)) and screw bellows **206** with plug **204** and lifting aid **237** onto the spindle **802**. See [Fig. 24](#).



Fig. 24

- Assemble the entire upper section with the body **100**. Tighten the hex. nuts **920/2** and hex. socket screws **914/1** for the pressure ring **124**.

### Lowering the bellows onto the seat

- For this purpose screw the adjusting screw **538** into the spring bonnet **513** until the spacer can be freely moved.



When tightening the adjusting screw **538**, hold the spindle **802** with a wrench on the counter nut to prevent it from turning so that the bellows **206** or the spring-type pin **939/1** are not damaged. See **Fig. 25**.

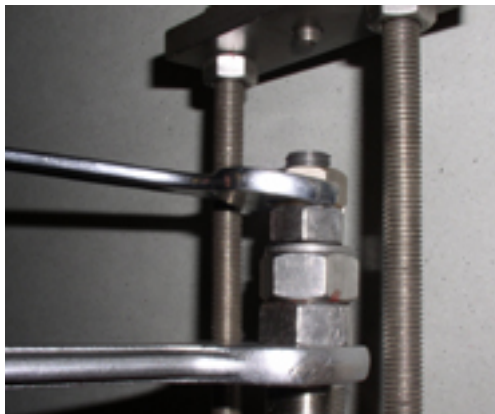

**Fig. 25**

- Undo the counter nut and remove the spacer.
- Now the valve can be set to the specified set pressure.
- Secure the spindle nut **534** and hex. nut with self-locking feature **929/1** on the end of the spindle and counter against each other. Set the adjusting screw **538** accordingly.



When screwing the hex. nut with self-locking feature **929/1** on or off the spindle **802** or when setting the adjusting screw **538**, hold the spindle with a wrench on the counter nut to prevent it from turning so that the bellows **206** or the spring-type pin **939/1** are not damaged. See **Fig. 25**.

## 9.9 Tests

Following the assembly of the valve, the lift and the test pressure must be checked.

### 9.9.1 Lift

#### Lift check:

- Remove the cap nut **935/1** from the lifting cap **535** and determine the height of the stem **802** up to the upper edge of the lifting cap **535**.
- Determine the dimension from the raised face of the valve inlet to the plug in both the closed and fully opened state.
- Actuate the lifting lever **238** until the mechanical travel stop can be felt.

The measurement can be made with a slide calliper gauge and a depth indicator to DIN 862.



The lift is derived from the difference in the two heights. It must be at least as high as the lift given in the test certificate.

### 9.9.2 Adjustment of set pressure

According to UG-136 (d)(4) each pressure relief valve shall be tested to demonstrate its popping or set pressure. Pressure relief valves marked for gas or vapour may be tested with air. Pressure relief valve marked for liquid service shall be tested with water or other suitable liquid.

In mounted condition the KSEA/F is set by adjustment of the screw to the required set pressure. For tests with air the set point is the pressure at which the valve discs moves in the opening direction a larger amount, as compared with the corresponding movements at higher or lower pressures.

For tests with water, the correct testing point is the pressure measured at the valve inlet, at which the first steady stream of liquid is visually detected at the valve outlet.

### 9.9.3 Pressure setting

When a single pressure relief device is used, the set pressure marked on the device shall not exceed the maximum allowable working pressure of the vessel.

When the required capacity is provided in more than one pressure relief device, only one pressure relief device need be set at or below the maximum allowable working pressure, and the additional pressure relief devices maybe set to open at higher pressures but in no case at a pressure higher than 105% of the maximum allowable working pressure.

The correct set pressure is documented on the inspection sheet.

### 9.9.4 Set pressure tolerances

According to UG-134 (d)(1) the set pressure tolerance shall not exceed  $\pm 0,138$  bar ( $\pm 2$  psi) for pressures up to and including 4.83 bar (70 psi) and  $\pm 3\%$  for pressures above 4.83 bar (70 psi).

### 9.9.5 Seat tightness test

- ◆ After completion of the tests required by UG-136 (d)(4) seat tightness test shall be conducted.
- ◆ This test should take place on a test bench with a neutral medium such as air or water.
- ◆ Regarding their suitability and precision, the employed pressure gauges must conform to the requirements of the ASME Code Section VIII, Division 1, UG-102.
- ◆ Unless otherwise designated by a Manufacturer's published pressure relief valve specification, the seat tightness test and acceptance criteria shall be in accordance with API 527-1991.
- ◆ The valve shall be vertically mounted on the test stand.
- ◆ To check the seat tightness pressure, the pressure in the valve inlet is slowly decreased until the valve is bubble-tight.

### 9.9.6 Seat tightness test with air

- ◆ Pressure relief valves marked for gas or vapour may be leakage tested with air.
- ◆ According to API 527, the bubbles are led by a test hose with an outside diameter of 7.9 mm (5/16") and a wall thickness of 0.89 mm (0.035") in a container filled with water whereby the test hose discharges 12.7 mm (0,5") below the surface of the water.
- ◆ The tube end shall be cut square and smooth. The tube shall be perpendicular to the surface of the water.
- ◆ Leakage test pressure for testing with air:
  - ◆ For set pressures greater than 3.45 barg (50 psig) the leakage test pressure is 90 % of the set pressure.
  - ◆ For set pressures equal or less 3.45 barg (50 psig) the leakage test pressure is 0.344 barg (5 psig) less than the set pressure.

### 9.9.7 Leakage test with air

- ◆ Before the leakage test, the set pressure shall be demonstrated and all valve body joints and fittings should be checked with a suitable solution to ensure that all joints are tight.
- ◆ Before the bubble count, the test pressure shall be applied for at least 1 minute for valve whose nominal pipe size is 50 mm (2") or smaller, 2 minutes for a valve whose nominal pipe size is 80 mm (3") or 100 mm (4").
- ◆ The valve shall then be observed for leakage for at least 1 minute.

### 9.9.8 Acceptance criteria (air)

For a soft seated valve, there shall be no leakage for 1 minute (0 bubbles pro minute).

### 9.9.9 Seat tightness test with water

- ◆ Pressure relief valves marked for liquid service shall be tested with water or other suitable liquid.
- ◆ Leakage test pressure for testing with water:
  - ◆ For set pressures greater than 3.45 barg (50 psig) the leakage test pressure is 90 % of the set pressure.
  - ◆ For set pressures equal or less 3.45 barg (50 psig) the leakage test pressure is 0.344 barg (5 psig) less than the set pressure.

### 9.9.10 Leakage test with water

- ◆ Before starting the seat tightness test the set pressure shall be demonstrated, and the outlet body bowl shall be filled with water, which shall be allowed to stabilize with no visible flow from the valve outlet.
- ◆ The inlet pressure shall then be increased to the test pressure. The valve shall then be observed for 1 minute at the test pressure.

### 9.9.11 Acceptance criteria (water)

For soft seated valves, there shall be no leakage for 1 minute.

### 9.9.12 Back pressure test

- ◆ According to UG 136 (d)(3), valves constructed with Low Pressure Bellows shall be tested with air or nitrogen not to exceed a pressure of 15 psig.
- ◆ Valves constructed with high pressure bellows shall be tested with air or nitrogen at 30 psig or otherwise stated by special customer requirement not to exceed 45 psig. The special customer requirement will be indicated on the Inspection Sheet.
- ◆ Back pressure tests will be performed by pressurizing valve body with air or nitrogen through outlet.
- ◆ Leakage may be detected by applying soap solution or leakage spray to valve body.
- ◆ Note possible leakage at construction seams.
- ◆ If leakage is detected, tighten applicable construction bolting.
- ◆ If leakage persists, disassemble valve, identify leak point, repair or replace applicable components, assemble and retest.

## 10 Drawings

### 10.1 Legend

<b>100</b>	body
<b>117</b>	thrust flange
<b>122</b>	inlet nozzle
<b>124</b>	pressure ring
<b>204</b>	plug
<b>205</b>	seat
<b>206</b>	bellows
<b>237</b>	lifting aid
<b>238</b>	lifting lever
<b>305</b>	bearing guide
<b>306</b>	stem guide
<b>307/1</b>	guide bush
<b>308</b>	insert sleeve
<b>395</b>	axial-needle roller cage
<b>396</b>	axial-washer
<b>400/1</b>	o-ring
<b>420</b>	thrust ring, two pieces
<b>513</b>	spring bonnet
<b>534</b>	stem nut
<b>535</b>	lifting cap
<b>536</b>	upper spring plate
<b>537</b>	lower spring plate
<b>538</b>	adjusting screw
<b>539</b>	locking plate
<b>554/2</b>	washer
<b>555</b>	centering nut
<b>561/1</b>	grooved pin
<b>802</b>	spindle
<b>900/1</b>	ring bolt
<b>901/x</b>	hex. screw
<b>902/x</b>	stud screw
<b>914/1</b>	hex. Socket screw
<b>918/1</b>	threaded rod
<b>920/x</b>	hex. nut
<b>920/3</b>	hex. nut, plain
<b>927/1</b>	cap nut
<b>929/1</b>	prevailing torque type hex. nut
<b>932/x</b>	snap ring
<b>934/1</b>	lock washer
<b>935/1</b>	lead seal
<b>936/x</b>	toothed lock washer
<b>938/1</b>	hex. head screw plug
<b>939/1</b>	spring type pin
<b>952/1</b>	pressure spring

#### Option blocking screw

<b>901/3</b>	hex. screw
<b>918/1</b>	threaded rod
<b>927/1B</b>	cap nut
<b>929/2</b>	prevailing torque type hex. nuts

#### Option signal transmitter

<b>540</b>	support, signal transmitter
	includes:
<b>400/2</b>	o-ring (design with blocking screw)
<b>400/3</b>	o-ring
<b>541</b>	support, upper part
<b>542</b>	support, lower part
<b>901/4</b>	hex. screw
	(design with blocking screw)
<b>904/1</b>	setscrew
<b>939/2</b>	spring-type pin
<b>805</b>	stem extension
<b>859</b>	signal transmitter
<b>920/4</b>	hex. nut

#### Option travel stop

<b>508</b>	travel stop
------------	-------------

#### Option design for highly permeating media

<b>307/2</b>	guide bush
<b>860</b>	spring turn unit

10.2 Sectional drawing KSEA/F

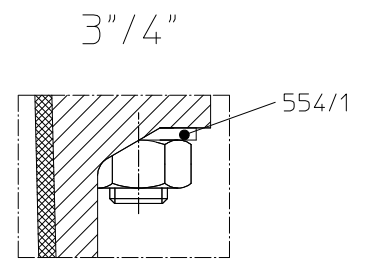
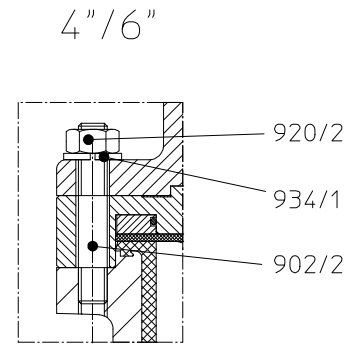
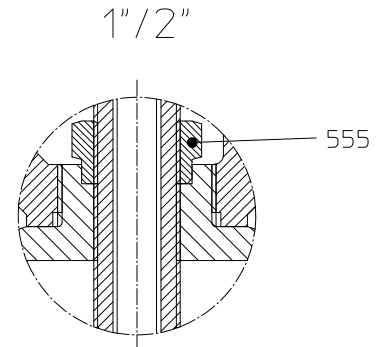
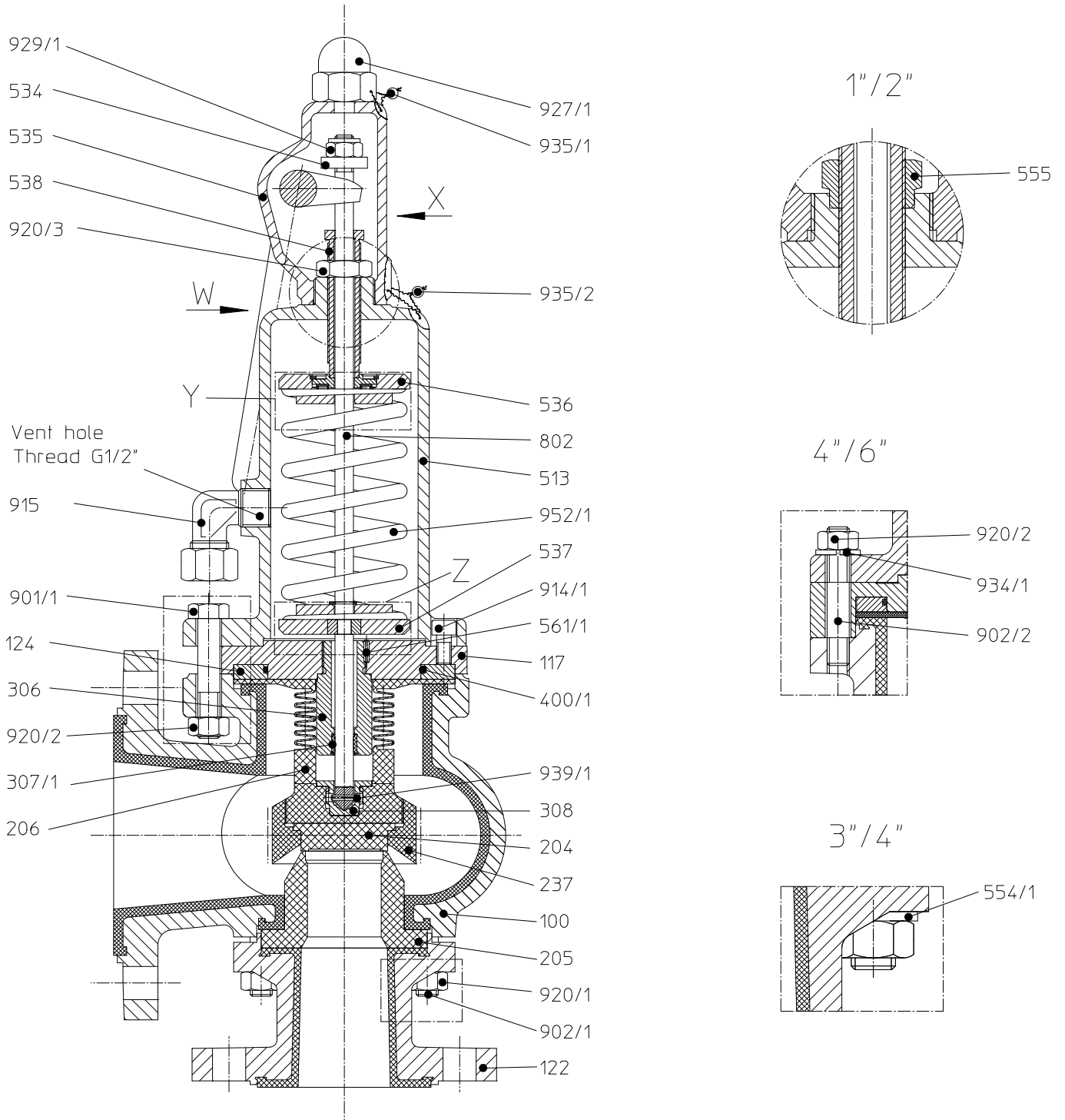

9530-00-3010/4-0

10.3 Views

**View X**

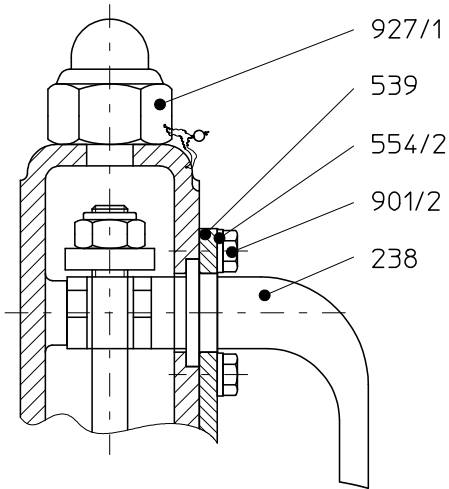

**View X**

DN 4"/6"

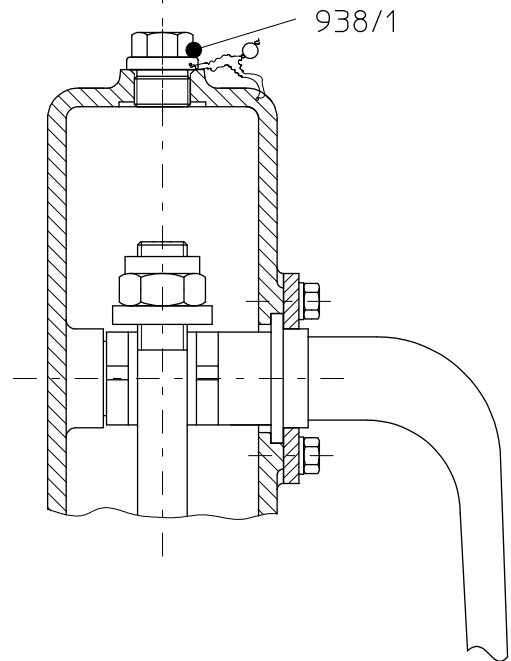

**Detail Y**

upper spring plate

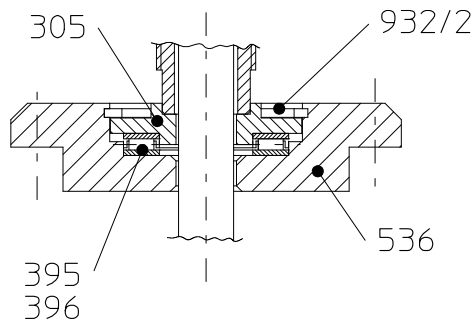

**View W**

DN 4"/6"

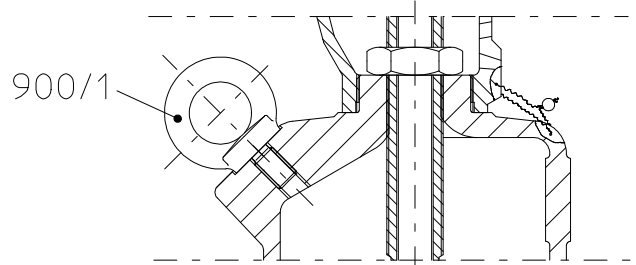

**Detail Z**

lower spring plate

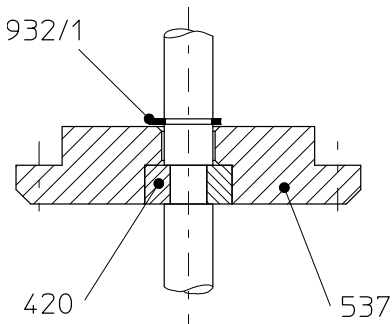

10.4 Dimensional drawing

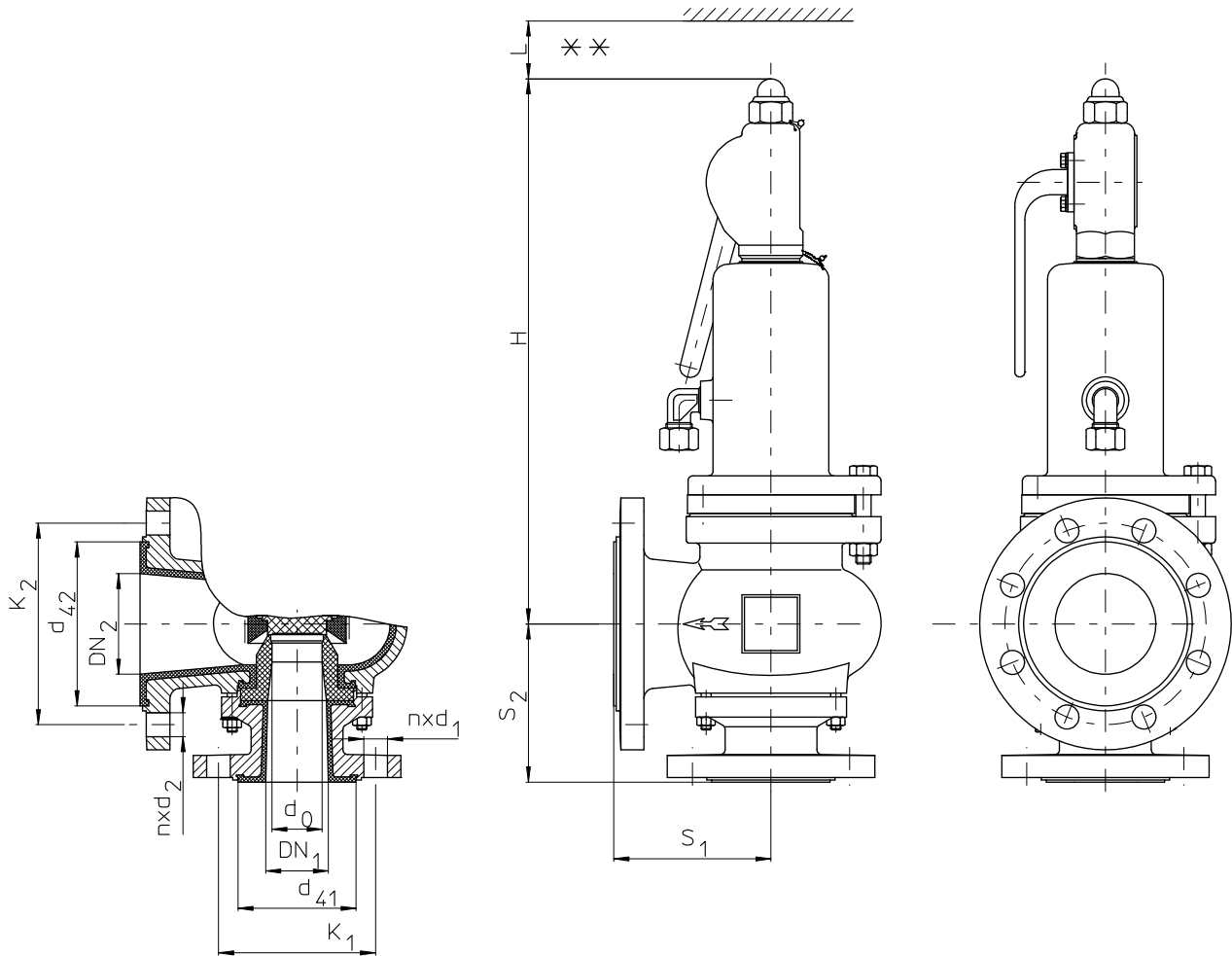

Main dimensions										
valve size	d <sub>0</sub>		s <sub>1</sub>		s <sub>2</sub>		H		L	
	mm	inch	mm	inch	mm	inch	mm	inch	mm	inch
1" / 2"	22	0.866	100	3.937	104.7	4.125	355	13.98	120	4.72
2" / 3"	40	1.574	125	4.921	136.5	5.375	435	17.12	120	4.72
3" / 4"	50	1.968	155	6.10	155	6.10	525	20.67	140	5.51
4" / 6"	80	3.149	200	7.874	220	8.661	710	27.95	180	7.08

Connecting dimensions according to ASME B16.5 Class 150																
Valve type	Inlet								Outlet							
	DN 1		d <sub>4</sub> 1		K 1		nxd 1		DN 2		d <sub>4</sub> 2		K 2		nxd 2	
	mm	inch	mm	inch	mm	inch	mm	inch	mm	inch	mm	inch	mm	inch	mm	inch
1"/2"	25	1	50.8	2	79.4	3.125	4x15.9	4x0.625	50	2	92.1	3.625	120.6	4.75	4x19	4x0.75
2"/3"	50	2	92.1	3.625	120.6	4.75	4x19	4x0.75	80	3	127	5	152.4	6	4.x19	4x0.75
3"/4"	80	3	127	5	152.4	6	4.x19	4x0.75	100	4	157.2	6.187	190.5	7.5	8x19	8x0.75
4"/6"	100	4	157.2	6.187	190.5	7.5	8x19	8x0.75	150	6	215.9	8.5	241.3	9.5	8x22.2	8x0.875



## Safety Information / **Declaration of No Objection** Concerning the Contamination of Richter-Pumps, -Valves and Components

### 1 SCOPE AND PURPOSE

Each entrepreneur (operator) carries the responsibility for the health and safety of his employees. This extends also to the personnel, who implements repairs with the operator or with the contractor.

Enclosed declaration is for the information of the contractor concerning the possible contamination of the pumps, valves and component sent in for repair. On the basis of this information for the contractor is it possible to meet the necessary preventive action during the execution of the repair.

Note: The same regulations apply to repairs **on-site**.

### 2 PREPARATION OF DISPATCH

Before the dispatch of the aggregates the operator must fill in the following declaration completely and attach it to the shipping documents. The shipping instructions indicated in the respective manual are to be considered, for example:

- Discharge of operational liquids
- remove filter inserts
- lock all openings hermetically
- proper packing
- Dispatch in suitable transport container
- Declaration of the contamination fixed **outside!!** on the packing

# Declaration about the Contamination of Richter Pumps, -Valves and Components

The repair and/or maintenance of pumps, valves and components can only be implemented if a completely filled out declaration is available. If this is not the case, delay of the work will occur. If this declaration is not attached to the devices, which have to be repaired, the transmission can be rejected.

**Every aggregate has to have it's own declaration.**

This declaration may be filled out and signed only by authorized technical personnel of the operator.

Contractor/dep./institute : _____ Street : _____ Postcode, city: _____ Contact person: _____ Phone : _____ Fax : _____ End user : _____	Reason for transmitting <input checked="" type="checkbox"/> Please mark the applicable <b>Repair:</b> <input type="checkbox"/> subject to fee <input type="checkbox"/> Warranty <b>Exchange:</b> <input type="checkbox"/> subject to fee <input type="checkbox"/> Warranty <input type="checkbox"/> Exchange/ Replacement already initiated/received <b>Return:</b> <input type="checkbox"/> Leasing <input type="checkbox"/> Loan <input type="checkbox"/> for credit note																																												
<b>A. Details of Richter-product:</b>																																													
<b>Classification:</b> _____ <b>Article number:</b> _____ <b>Serial number:</b> _____	<b>Failure description:</b> _____ <b>Equipment:</b> _____ <b>Application tool:</b> _____ <b>Application process:</b> _____																																												
<b>B. Condition of the Richter-product:</b>																																													
<table border="1" style="width:100%; border-collapse: collapse;"> <thead> <tr> <th style="width:30%;"></th> <th style="width:10%; text-align:center;">no<sup>1)</sup></th> <th style="width:10%; text-align:center;">yes</th> <th style="width:10%; text-align:center;">no</th> </tr> </thead> <tbody> <tr> <td>Was it in operation ?</td> <td style="text-align:center;"><input type="checkbox"/></td> <td style="text-align:center;"><input type="checkbox"/></td> <td style="text-align:center;"><input checked="" type="checkbox"/></td> </tr> <tr> <td>Drained (product/operating supply item) ?</td> <td style="text-align:center;"><input checked="" type="checkbox"/></td> <td style="text-align:center;"><input type="checkbox"/></td> <td style="text-align:center;"><input type="checkbox"/></td> </tr> <tr> <td>All openings hermetically locked!</td> <td style="text-align:center;"><input checked="" type="checkbox"/></td> <td style="text-align:center;"><input type="checkbox"/></td> <td style="text-align:center;"><input type="checkbox"/></td> </tr> <tr> <td>Cleaned ?</td> <td style="text-align:center;"><input checked="" type="checkbox"/></td> <td style="text-align:center;"><input type="checkbox"/></td> <td style="text-align:center;"><input type="checkbox"/></td> </tr> </tbody> </table>		no <sup>1)</sup>	yes	no	Was it in operation ?	<input type="checkbox"/>	<input type="checkbox"/>	<input checked="" type="checkbox"/>	Drained (product/operating supply item) ?	<input checked="" type="checkbox"/>	<input type="checkbox"/>	<input type="checkbox"/>	All openings hermetically locked!	<input checked="" type="checkbox"/>	<input type="checkbox"/>	<input type="checkbox"/>	Cleaned ?	<input checked="" type="checkbox"/>	<input type="checkbox"/>	<input type="checkbox"/>	<table border="1" style="width:100%; border-collapse: collapse;"> <thead> <tr> <th style="width:60%;"></th> <th style="width:10%; text-align:center;">no<sup>1)</sup></th> <th style="width:10%; text-align:center;">yes</th> </tr> </thead> <tbody> <tr> <td>toxic</td> <td style="text-align:center;"><input type="checkbox"/></td> <td style="text-align:center;"><input type="checkbox"/></td> </tr> <tr> <td>caustic</td> <td style="text-align:center;"><input type="checkbox"/></td> <td style="text-align:center;"><input type="checkbox"/></td> </tr> <tr> <td>flammable</td> <td style="text-align:center;"><input type="checkbox"/></td> <td style="text-align:center;"><input type="checkbox"/></td> </tr> <tr> <td>explosive<sup>2)</sup></td> <td style="text-align:center;"><input type="checkbox"/></td> <td style="text-align:center;"><input type="checkbox"/></td> </tr> <tr> <td>mikrobiological<sup>2)</sup></td> <td style="text-align:center;"><input type="checkbox"/></td> <td style="text-align:center;"><input type="checkbox"/></td> </tr> <tr> <td>radioactive<sup>3)</sup></td> <td style="text-align:center;"><input type="checkbox"/></td> <td style="text-align:center;"><input type="checkbox"/></td> </tr> <tr> <td>other pollutant</td> <td style="text-align:center;"><input type="checkbox"/></td> <td style="text-align:center;"><input type="checkbox"/></td> </tr> </tbody> </table>		no <sup>1)</sup>	yes	toxic	<input type="checkbox"/>	<input type="checkbox"/>	caustic	<input type="checkbox"/>	<input type="checkbox"/>	flammable	<input type="checkbox"/>	<input type="checkbox"/>	explosive <sup>2)</sup>	<input type="checkbox"/>	<input type="checkbox"/>	mikrobiological <sup>2)</sup>	<input type="checkbox"/>	<input type="checkbox"/>	radioactive <sup>3)</sup>	<input type="checkbox"/>	<input type="checkbox"/>	other pollutant	<input type="checkbox"/>	<input type="checkbox"/>
	no <sup>1)</sup>	yes	no																																										
Was it in operation ?	<input type="checkbox"/>	<input type="checkbox"/>	<input checked="" type="checkbox"/>																																										
Drained (product/operating supply item) ?	<input checked="" type="checkbox"/>	<input type="checkbox"/>	<input type="checkbox"/>																																										
All openings hermetically locked!	<input checked="" type="checkbox"/>	<input type="checkbox"/>	<input type="checkbox"/>																																										
Cleaned ?	<input checked="" type="checkbox"/>	<input type="checkbox"/>	<input type="checkbox"/>																																										
	no <sup>1)</sup>	yes																																											
toxic	<input type="checkbox"/>	<input type="checkbox"/>																																											
caustic	<input type="checkbox"/>	<input type="checkbox"/>																																											
flammable	<input type="checkbox"/>	<input type="checkbox"/>																																											
explosive <sup>2)</sup>	<input type="checkbox"/>	<input type="checkbox"/>																																											
mikrobiological <sup>2)</sup>	<input type="checkbox"/>	<input type="checkbox"/>																																											
radioactive <sup>3)</sup>	<input type="checkbox"/>	<input type="checkbox"/>																																											
other pollutant	<input type="checkbox"/>	<input type="checkbox"/>																																											
If yes, with which cleaning agent: _____ and with which cleaning method: _____																																													
<sup>1)</sup> if "no", then forward to D.                      ← <sup>2)</sup> Aggregates, which are contaminated with microbiological or explosive substances, are only accepted with documented evidence of an approved cleaning. <sup>3)</sup> Aggregates, which are contaminated with radioactive substances, are not accepted in principle.																																													
<b>C. Details of the discharged materials (must be filled out imperatively)</b>																																													
1. <b>With which materials did the aggregate come into contact ?</b> Trade name and/or chemical designation of operational funds and discharged materials, material properties, e.g. as per safety data sheet (e.g. toxic, inflammable, caustic)																																													
<table border="1" style="width:100%; border-collapse: collapse;"> <thead> <tr> <th style="width:30%;">X Trade name:</th> <th style="width:70%;">Chemical designation:</th> </tr> </thead> <tbody> <tr><td>a)</td><td></td></tr> <tr><td>b)</td><td></td></tr> <tr><td>c)</td><td></td></tr> <tr><td>d)</td><td></td></tr> </tbody> </table>		X Trade name:	Chemical designation:	a)		b)		c)		d)																																			
X Trade name:	Chemical designation:																																												
a)																																													
b)																																													
c)																																													
d)																																													
2. <b>Are the materials specified above harmful to health ?</b> <table style="display: inline-table; border: none;"><tr><td style="text-align:center; border-bottom: 1px solid black;">no</td><td style="text-align:center; border-bottom: 1px solid black;">yes</td></tr><tr><td style="text-align:center;"><input type="checkbox"/></td><td style="text-align:center;"><input type="checkbox"/></td></tr></table> ←		no	yes	<input type="checkbox"/>	<input type="checkbox"/>																																								
no	yes																																												
<input type="checkbox"/>	<input type="checkbox"/>																																												
3. <b>Dangerous decomposition products during thermal load ?</b> <table style="display: inline-table; border: none;"><tr><td style="text-align:center; border-bottom: 1px solid black;">no</td><td style="text-align:center; border-bottom: 1px solid black;">yes</td></tr><tr><td style="text-align:center;"><input type="checkbox"/></td><td style="text-align:center;"><input type="checkbox"/></td></tr></table>		no	yes	<input type="checkbox"/>	<input type="checkbox"/>																																								
no	yes																																												
<input type="checkbox"/>	<input type="checkbox"/>																																												
If yes, which ones ? _____																																													

**D. Mandatory declaration:** We assure that the data in this explanation are truthful and complete and as a signatory I am able to form an opinion about this. We are aware that we are responsible towards the contractor for damages, which results from incomplete and incorrect data. We commit ourselves to exempt the contractor from claims for damages of thirds resulting from incomplete or incorrect data. We are aware that we are directly responsible towards thirds, irrespective of this declaration, which belongs in particularly to the employees of the contractor consigned with the handling repair of the product.

Name of the authorized person (in block letters): \_\_\_\_\_

\_\_\_\_\_ Date

\_\_\_\_\_ Signature

Company stamp

## FAX

**Fax No. ()**

**Pages (incl. cover sheet) ()**

**To:**

()

Richter Chemie-Technik GmbH  
Otto-Schott-Straße 2  
D-47906 Kempen

Telefon +49 (0) 21 52/146-0  
Telefax +49 (0) 21 52/146-190

richter-info@richter-ct.com  
www.richter-ct.com

Contact person:  
()

Reference:  
()

Extension:  
- ()

E-Mail Address:  
()

Date:  
()

**Your order No.:** ()

**Our Kom. No.:** ()

**Serial No.:** ()

Dear Sirs,

The compliance with laws for the industrial safety obligates all commercial enterprises to protect their employees and/or humans and environment against harmful effects while handling dangerous materials.

The laws are such as: the Health and Safety at Work Act (ArbStättV), the Ordinance on Harzadous Substances (GefStoffV, BIOSTOFFV), the procedures for the prevention of accidents as well as regulations to environmental protection, e.g. the Waste Management Law (AbfG) and the Water Resources Act (WHG)

An inspection/repair of Richter products and parts will only take place, if the attached explanation is filled out correctly and completely by authorized and qualified technical personnel and is available.

In principle, radioactively loaded devices sent in, are not accepted.

Despite careful draining and cleaning of the devices, safety precautions should be necessary however, the essential information must be given.

The enclosed declaration of no objection is part of the inspection/repair order. Even if this certificate is available, we reserve the right to reject the acceptance of this order for other reasons.

Best regards  
RICHTER CHEMIE-TECHNIK GMBH

Enclosures

()