

### CAUTION:

If any questions arise concerning the proper installation or maintenance of our products, please contact Protectoseal or one of our Authorized Representatives.

When installing any Protectoseal device, the legal, corporate and advisory safety regulations and procedures appropriate for the specific installation site must be fully understood and followed.

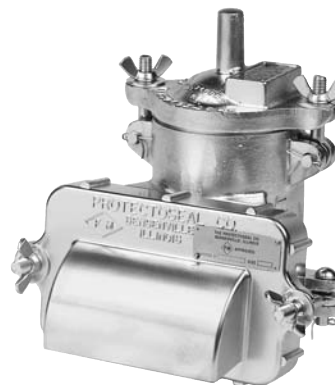

### CLASSIFICATION:

The Protectoseal 830E-D Series Conservation Vents with Flame Arrester are classified as End-of-Line Deflagration Flame Arresters. They are suitable for arresting an unconfined deflagration propagating into a vessel or enclosure. The markings on the arrester identify restrictions concerning their use with respect to gas/vapor group and maximum operational temperature / pressure.

### OPERATIONAL LIMITS:

The Protectoseal Series 830E-D Flame Arresters are suitable for use under the following limitations:

- Maximum Operational Temperature = 60°C (140°F)
- Maximum Operational Pressure = 1.1 bar (15.9 PSIA)
- Explosion Group (Ex. G.) = IIA

### MARKINGS:

Each Protectoseal 830E-D Series Conservation Vent with Flame Arrester includes an Identification Label and a Warning Label.

#### Identification Label

THE PROTECTOSEAL COMPANY BENSENVILLE, IL	
SIRA 10ATEX9143X	
DEF IIA	
BC c T <sub>0</sub> = 60° C	<input type="text"/>
P <sub>0</sub> = 1.1 BAR	MODEL NUMBER
EN 12874	<input type="text"/>
ISO 16852	SERIAL NUMBER
CE 0518	

The Identification Label includes:

1. SIRA certificate number
2. Deflagration arrester and gas/vapor explosion group designation
3. Burn time designation
4. Maximum operational temperature
5. Maximum operational pressure
6. Model number and unique serial number
7. Standards designations
8. SIRA identification number

#### Warning Label

<b>WARNING</b>		
FLAME ARRESTERS HAVE INSTALLATION AND APPLICATION LIMITS; TYPE DESIGNATION ACCORDING TO ISO 16852		
DEF	L <sub>v</sub> /D= na	BC: c
Ex.G	<input type="text"/>	T <sub>0</sub> = 60°C    p <sub>0</sub> = 1.1 bar

The Warning Label indicates that limitations to the installation and application criteria for the arrester exists and identifies type designation according to ISO 16852.

- DEF** - indicates that the arrester is a deflagration flame arrester
- L<sub>v</sub>/D = na** - indicates that the arrester is suitable for end-of-line applications only
- BC: c** - indicates a rating of no burn time
- Ex.G** - indicates the appropriate explosion group that the arrester is suitable for (IIB3 or IIA as appropriate)
- T<sub>0</sub> = 60°C** - indicates a maximum operational temperature of 60°C (140°F)
- p<sub>0</sub> = 1.1 bar** - indicates a maximum operational pressure of 1.1 bar (15.9 PSIA)

Additional labels provide pressure / vacuum setting information, identification and safety warnings.

## INSTALLATION:

If any questions arise concerning the proper installation of vents, please contact Protectoseal or one of our Authorized Representatives.

**CAUTION:** When installing any Protectoseal venting device, the legal, corporate and advisory safety regulations and procedures appropriate for the specific installation site must be fully understood and followed:

1. When pressure or vacuum weights (packed separately if heavy) are included with a unit, the weights should be inspected, properly identified and set aside for later installation. Weights will be stamped with a serial number matching the number on the vent, identification as pressure or vacuum weights and a statement as to the contribution that each weight provides to the total pressure or vacuum setting.
2. The pressure and vacuum pallet assemblies on the No. 830E-D Series Vents are stacked vertically inside the vent housing. Note: The vacuum pallet assembly is larger in diameter than the pressure pallet assembly and the vacuum pallet assembly is positioned above the pressure pallet assembly.
3. The cover on top of the vent housing provides access to the pressure and vacuum pallet assemblies. The weatherhood(s) on the side of the vent housing provide access to the flame arrester element(s).

## INSTALLATION PROCEDURE:

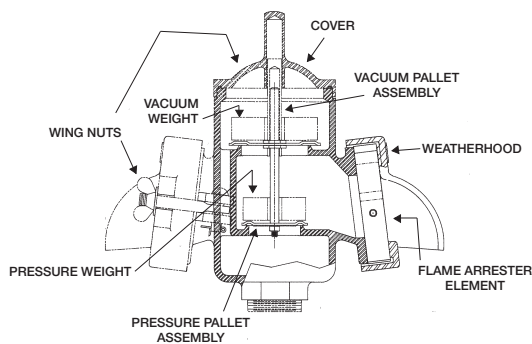

1. Loosen wing nuts and remove cover.
2. Withdraw pressure / vacuum pallet assemblies and remove protective cardboard and tape from each assembly.
3. Remove the protective flange covers.
4. Check carefully to insure that no packing materials remain on or inside the vent housings.
5. Mount the vent to the appropriate inlet and /or outlet flange using gaskets or seal compatible with service conditions. For best performance, the vent should be mounted level so that the seating surfaces are no more than 1° off horizontal.

6. Reinstall the pressure pallet assembly. Setting weights (if required) should be installed by engaging the hole in the weight on the pressure pallet assembly stem. Reinstall the vacuum pallet assembly. **CAUTION: THE STEM OF THE PRESSURE PALLET ASSEMBLY MUST ENGAGE THE HOLE IN THE BOTTOM OF THE HOLLOW VACUUM PALLET ASSEMBLY STEM.** Setting weights (if required) should be installed by engaging the hole in the weight on the vacuum pallet assembly stem.
7. Replace the cover. **CAUTION: MAKE SURE THAT THE VACUUM PALLET ASSEMBLY STEM POSITIVELY ENGAGES THE STEM GUIDE HOLE IN THE COVER.** Each pallet assembly must be free to move upwards, with the pallet stem traveling into their respective stem guide.
8. Replace wing nuts and tighten to secure cover in position.

## MAINTENANCE:

Protectoseal recommends that our products be inspected and maintained according to the normal maintenance schedule of the facility. At a minimum, maintenance should be conducted annually. More frequent maintenance may be required, and should be scheduled, for unusual service conditions.

If any questions arise concerning the proper maintenance of vents, please contact Protectoseal or one of our Authorized Representatives.

**CAUTION: When maintaining any Protectoseal device, the legal, corporate and advisory safety regulations and procedures appropriate for the specific installation site must be fully understood and followed.**

**CAUTION: Tank vapor space pressure or vacuum should be relieved before any maintenance operations are undertaken.**

## MAINTENANCE PROCEDURE:

1. Loosen cover wing nuts and remove cover.
2. Inspect the gasket on the covers. Replace if deteriorated or damaged.
3. Remove any loose dirt or foreign material from the housing interior and exterior. Check inside the stem guide hole of the cover and the vacuum pallet stem and remove any dirt or accumulation of foreign material from these holes.
4. Withdraw pressure / vacuum pallet assemblies and set aside for inspection. Note: Identify any weights on the pressure / vacuum pallet assemblies for later reinstallation.
5. Inspect and clean the machined seating surfaces in the vent housings with a suitable cleaning fluid. Seats should be free of nicks, mars or accumulations of foreign material. **CAUTION: DO NOT USE A FILE OR OTHER SHARP TOOL TO CLEAN SEATING SURFACE.**

6. Inspect the pallet assemblies. If pallets are deteriorated or bent, they must be replaced. Inspect the diaphragm material in the pallet assemblies. The diaphragms must be clean, flat and smooth. If the diaphragm material is deteriorated, it must be replaced. Make sure that all nuts and screws on the pallet assemblies are tightened securely.
7. Reinstall the pressure pallet assembly. Setting weights (if required) should be installed by engaging the hole in the weight on the pressure pallet assembly stem. Reinstall the vacuum pallet assembly. **CAUTION: THE STEM OF THE PRESSURE PALLET ASSEMBLY MUST ENGAGE THE HOLE IN THE BOTTOM OF THE HOLLOW VACUUM PALLET ASSEMBLY STEM.**
8. Replace the cover. **CAUTION: MAKE SURE THAT THE VACUUM PALLET ASSEMBLY STEM POSITIVELY ENGAGES THE STEM GUIDE HOLE IN THE COVER.** Each pallet assembly must be free to move upwards, with the pallet stem traveling into their respective stem guide. Note: Heavy weights may be provided with tapped holes to temporarily attach lifting hardware to facilitate installation. Any such threaded fasteners used during installation must be removed from the weights. Foreign objects will limit the lift capacity of the pallet assemblies and will reduce the rated flow capacity of the vent.
9. Replace wing nuts and tighten to secure cover in position.
10. Loosen the wing nuts on the weatherhood(s). Remove the weatherhood(s) to expose the flame arrester element.
11. Remove the complete arrester element by sliding it off the support studs.
12. Inspect the arrester assembly. The passages between the individual plates should be clear. Blow out any loose dirt or foreign material. If necessary, the element may be immersed in a suitable solvent to remove gums and deposits.
13. If accumulations cannot be removed in this manner, the plate assembly can be removed from its frame by loosening the screws that hold the plate assembly into the frame. The plates can then be rotated about the off-center stud and cleaned individually, before reassembly into the frame. **CAUTION: DO NOT REMOVE PLATES FROM STUD. DO NOT BEND PLATES. CONTACT PROTECTOSEAL IF ANY QUESTIONS ARISE.** Replace plate assembly in frame and secure with screws.
14. If plates are corroded or damaged, the element assembly must be replaced.
15. Reposition flame arrester elements on the housing by aligning holes in frame with the studs on the housing. Frames should fit flush against housing surface.
16. Replace weatherhood(s) and secure in place by tightening wing nuts.

## The Protectoseal Company EC Declaration of Conformity

**Manufacturer:** The Protectoseal Company  
225 Foster Avenue  
Bensenville, IL 60106  
USA

**Quality Assurance Notification Certificate Number:**  
SIRA 10 ATEX M458 issued by  
SIRA Certification Service  
(Notified Body No. 0518)  
Rake Lane  
Eccleston, Chester, CH4 9JN, UK

---

The Protectoseal Company herewith declares that the equipment detailed below is in conformity with the applicable provisions of the ATEX Directive 94/9/EC and has been found to comply with the Essential Health and Safety Requirements relating to the design and construction of equipment intended for use in potentially explosive atmospheres given in Annex II to the Directive.

**Equipment: Type 830E Range of End-of-Line Flame Arresters**

EC Type Examination Certificate #SIRA 10ATEX9143X issued by Sira Certification Service (address as listed above) – Notified Body No. 0518 in accordance with Article 9 of Directive 94/9/EC.

Applied Standards/Marking: EN 12874: 2001  
ISO 16852:2008

 IIA

 0518



---

Thomas C. Piotrowski  
Vice President – Engineering  
Document Number: SPEC-830E Revision: 0  
Issue Date: July 1, 2010



SERIES 830E-D

- Sizes DN 50 (2") through DN 150 (6")
- Type Approved according to ATEX Directive 94/9/EC, Standards EN 12874 and ISO 16852
- Suitable for use with Explosive Group IIA (NEC Group D)
- Settings achieved by weight loading
- Operating temperatures up to +60°C (140°F)
- Extremely low leakage rates prior to set point
- Patented, FEP film "Air-Cushioned Seating"
- Low-leak pallet design - certified test reports
- Factory tested / certified for leakage and correct settings
- Available in Aluminum, Ductile Iron, Steel and Stainless Steel

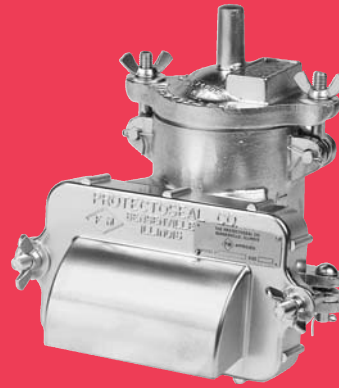

### OBJECTIVE

The Protectoseal Series No. 830E-D Combination Conservation Vent and Flame Arresters are designed to provide pressure and vacuum relief to maintain tank's vapor space within safe operating parameters. Vent settings minimize loss of product. Under pressure venting conditions, tank vapors are expelled to atmosphere. Also serves as an End-of-Line Flame Arrester to protect tank's vapor space from external sources of ignition. Maximum operating pressure is 1.1 bara (15.9 PSIA). The Series 830E-D Combination Vent / Flame Arresters are intended for use with vapors equivalent to IEC Explosion Group IIA (NEC Group D). Arresters are not for use in stabilized burning situations.

### TECHNIQUE

Pallets in vent housing minimize air and vapor loss as the tank "breathes". They open and close just enough to maintain safe working pressures and avoid damage to the tank. An integral flame arrester protects tank contents against fire and explosion caused by exterior sources of ignition. Rectangular plate-type flame arrester element(s) are mounted external to pallet assemblies for ease of use and are only exposed to vapors when venting.

Peripheral pallet assembly guides and center pallet stem guides insure proper alignment of pallet assembly on the seat and smooth lifting and reseating action.

### Optimized Performance Vents™

Protectoseal's "Optimized Performance Vents" incorporate patented features that provide the optimum overall vent performance with regard to sealing, set point, flow and resealing (blow down).

### SPECIAL FEATURES

**Fast Inspection, Easy Maintenance.** "Swing bolt design" permits removal of the vent housing cover and/or weatherhood(s) for easy, convenient handling for inspection and maintenance.

**Maintains Accurate Pressure Settings.** Set points are accurate to within +/- 3% across the entire range of available settings. Units may be weight loaded for use on installations requiring higher settings.

**Air-Cushioned Seating.** A flat, smooth diaphragm of FEP film is supported on both sides of an annular channel to form a floating air seal with the seat. An outer support rim assures proper seating.

**Automatic Condensate Drainage.** Vertically mounted, rectangular plate-type flame arrester is employed for self-drainage of condensate. Grids are mounted externally and are only exposed to vapors when venting.

**Positive Flame Arresting.** Correct air spacing between the individual plates is assured through a series of precision embossings on the face of each plate. Each plate is fabricated from heavy gauge metal to resist distortion during cleaning and reassembly.

**Sizes Available.** DN 50 (2"), DN 80 (3"), DN 100 (4") and DN 150 (6"). Please refer to dimension chart on reverse for flange connection options.

**Test Lab Listings.** Type Approved according to ATEX Directive 94/9/EC, Standards EN 12874 and ISO 16852. Refer to Protectoseal Series 830 for Factory Mutual (FM) or Underwriters Laboratories (UL) arresters.

**PRO-FLOW III® Sizing and Selection Software.** Use PRO-FLOW III® to select the correct size unit for pressure and vacuum relief calculated in accordance with API 2000, ISO 28300, NFPA 30 and OSHA 1910.106.

**Quality Assurance.** Each unit is factory tested for leakage and correct settings to meet Protectoseal's high standards prior to shipment.

### CONSTRUCTION

A comprehensive range of materials is offered as shown in the chart below. Other materials and features can be furnished upon request.

#### Available Options.

- Alternate diaphragm materials
- Material certifications for castings
- Lower than standard minimum pressure and /or vacuum setting
- Higher than standard maximum pressure and / or vacuum setting

Series	Housing	Pallet	Pallet Diaphragm	Nipple/ Flange	Arrester Grid Assy.
A830E_-D	Aluminum	316 S.S.	FEP Film	Aluminum	316 S.S.
C830E_-D	Ductile Iron	316 S.S.	FEP Film	Steel	316 S.S.
F830E_-D	316 S.S.	316 S.S.	FEP Film	316 S.S.	316 S.S.
S830E_-D	Steel	316 S.S.	FEP Film	Steel	316 S.S.

*Note: Please refer to charts on reverse for ordering options.*

## SERIES 830E-D PART NUMBERING SYSTEM

DN 25 (1"), DN 50 (2"), DN 80 (3") & DN 100 (4") Sizes										
DIGIT #:	1	2	3	4	5	6	7	8	9	
1	Material:	A	Aluminum Body, 316 S.S. Element/Pallet Assemblies							
		C	Ductile Iron Body, 316 S.S. Element/Pallet Assemblies							
		F	316 S.S. Body, Element/Pallet Assemblies							
		S	Steel Body, 316 S.S. Element/Pallet Assemblies							
2 & 3	Series No.	83	End-of-Line Combination Vent & Flame Arrester							
4	Size	2	DN 50 (2")							
		3	DN 80 (3")							
		4	DN 100 (4")							
5	Type	E								
6	Connection	1	FNPT							
		2	ANSI 125# FF Flange (Aluminum)							
		2	ANSI 150# RF Flange (Other Materials)							
		3	DIN PN 16 FF Flange (Aluminum)							
		3	DIN PN 16 RF Flange (Other Materials)							
7	Flange / Nipple	0	None (FNPT Connection)							
		1	When Material Code is "A" (Aluminum)							
		1	When Material Code is "F" (316 S.S.)							
		2	When Material Code is "C" or "S" (Steel)							
8		-								
9	Vapor Group	D	Explosion Group IIA (NEC Group D)							

DN 150 (6") Size									
DIGIT #:	1	2	3	4	5	6	7	8	
1	Material:	A	Aluminum Body, 316 S.S. Element/Pallet Assemblies						
		F	316 S.S. Body, Element/Pallet Assemblies						
		S	Steel Body, 316 S.S. Element/Pallet Assemblies						
2 & 3	Series No.	83	End-of-Line Combination Vent & Flame Arrester						
4	Size	6	DN 150 (6")						
5	Type	E							
6	Connection	1	ANSI 125# FF Flange (Aluminum)						
			ANSI 150# RF Flange (Other Materials)						
		2	DIN PN 16 FF Flange (Aluminum)						
			DIN PN 16 RF Flange (Other Materials)						
7		-							
8	Vapor Group	D	Explosion Group IIA (NEC Group D)						

### PART NO. EXAMPLE:

DIGIT #:	1	2	3	4	5	6	7	8	9
	F	8	3	2	E	3	1	-	D

**Description:** Body, Element & Pallet Assemblies - 316 S.S.  
 Size - DN 50 (2")  
 Connection - DIN PN 16 RF Flange  
 Flange / Nipple - 316 S.S.  
 Vapor Group IIA (NEC Group D)

## DIMENSIONS

(Please refer to numbering system above to complete Part No. NOTE: Dimensions shown are for reference only, contact Factory for certified drawings.)

Part No.	Connection - K			Ht A	Dia C	B.C D	Dia. E	Holes N
	FNPT	ANSI	DIN 16 PN					
1832E10-D	2"	-	-	320mm (12.63")	257mm (10.13")	-	-	-
1832E2 <sup>7</sup> -D	-	2"	-	371mm (14.63")	257mm (10.13")	120mm (4.75")	19mm (.75")	4
1832E3 <sup>7</sup> -D	-	-	DN 50	371mm (14.63")	257mm (10.13")	125mm (4.94")	18mm (.72")	4
1833E10-D	3"	-	-	376mm (14.81")	397mm (15.63")	-	-	-
1833E2 <sup>7</sup> -D	-	3"	-	432mm (17")	397mm (15.63")	152mm (6")	19mm (.75")	4
1833E3 <sup>7</sup> -D	-	-	DN 80	432mm (17")	397mm (15.63")	160mm (9.28")	18mm (.72")	8
1834E10-D	4"	-	-	400mm (15.75")	489mm (19.25")	-	-	-
1834E2 <sup>7</sup> -D	-	4"	-	470mm (18.5")	489mm (19.25")	190mm (7.5")	19mm (.75")	8
1834E3 <sup>7</sup> -D	-	-	DN 100	470mm (18.5")	489mm (19.25")	180mm (7.09")	18mm (.72")	8
1836E1-D	-	6"	-	457mm (18")	628mm (24.75")	240mm (9.5")	22mm (.87")	8
1836E2-D	-	-	DN 150	457mm (18")	628mm (24.75")	240mm (9.5")	22mm (.87")	8

Superscripted numbers refer to digits as indicated in the "Part Numbering System" chart.

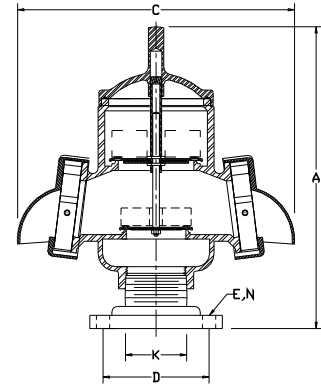

## PRESSURE AND/OR VACUUM SETTINGS

(Consult factory for settings outside of STANDARD range.)

Connection Size	STANDARD MINIMUM SETTINGS						STANDARD MAXIMUM SETTINGS					
	PRESSURE & VACUUM						PRESSURE			VACUUM		
	Aluminum			Other Materials			All Materials			All Materials		
	oz./in. <sup>2</sup>	in.W.C.	kPa	oz./in. <sup>2</sup>	in.W.C.	kPa	oz./in. <sup>2</sup>	in.W.C.	kPa	oz./in. <sup>2</sup>	in.W.C.	kPa
2" / DN 50	0.50	0.87	0.22	0.75	1.30	0.32	16.00	27.68	6.89	8.00	13.84	3.45
3" / DN 80	0.50	0.87	0.22	0.75	1.30	0.32	16.00	27.68	6.89	8.00	13.84	3.45
4" / DN 100	0.50	0.87	0.22	0.75	1.30	0.32	16.00	27.68	6.89	8.00	13.84	3.45
6" / DN 150	0.50	0.87	0.22	0.75	1.30	0.32	13.80	23.87	5.95	8.50	14.71	3.66



225 Foster Ave., Bensenville, IL 60106-1690  
 P 630.595.0800 F 630.595.8059  
 info@protectoseal.com www.protectoseal.com