

### CAUTION:

If any questions arise concerning the proper installation or maintenance of our products, please contact Protectoseal or one of our Authorized Representatives.

When installing any Protectoseal device, the legal, corporate and advisory safety regulations and procedures appropriate for the specific installation site must be fully understood and followed.



### CLASSIFICATION:

The Protectoseal 670E Series Flame Arresters are classified as End-of-Line Deflagration Flame Arresters. They are suitable for arresting an unconfined deflagration propagating into a vessel or enclosure. The markings on the arrester identify restrictions concerning the use of a specific arrester with respect to gas/vapor group and maximum operational temperature/pressure.

### OPERATIONAL LIMITS:

The Protectoseal Series 670E Flame Arresters are suitable for use under the following limitations:

- Maximum Operational Temperature = 60°C (140°F)
- Maximum Operational Pressure = 1.1 bar (15.9 PSIA)
- Explosion Group (Ex. G.) = As marked on the arresters: Group IIB3 or Group IIA
- Not for use in stabilized burning situations

### MARKINGS:

Each Protectoseal 670E Series Flame Arrester includes two labels: an Identification Label and a Warning Label.

#### Identification Label

THE PROTECTOSEAL COMPANY BENSENVILLE, IL	
SIRA 09ATEX9196X	
DEF <input type="text"/>	<input type="text"/>
BC c T <sub>0</sub> = 60° C <input type="text"/>	MODEL NUMBER
P <sub>0</sub> = 1.1 BAR	<input type="text"/>
EN 12874	SERIAL NUMBER
ISO 16852	
CE 0518	

The Identification Label includes:

1. SIRA certificate number
2. Deflagration arrester and gas/vapor explosion group designation
3. Burn time designation
4. Maximum operational temperature
5. Maximum operational pressure
6. Model number and unique serial number
7. Standards designations
8. SIRA identification number

#### Warning Label

<b>WARNING</b>		
FLAME ARRESTERS HAVE INSTALLATION AND APPLICATION LIMITS; TYPE DESIGNATION ACCORDING TO ISO 16852		
DEF	L <sub>v</sub> /D = n/a	BC: c
Ex.G	<input type="text"/>	T <sub>0</sub> = 60°C    p <sub>0</sub> = 1.1 bar

The Warning Label indicates that limitations to the installation and application criteria for the arrester exists and identifies type designation according to ISO 16852.

**DEF** - indicates that the arrester is a deflagration flame arrester

**L<sub>v</sub>/D = na** - indicates that the arrester is suitable for end-of-line applications only

**BC: c** - indicates a rating of no burn time

**Ex.G** - indicates the appropriate explosion group that the arrester is suitable for (IIB3 or IIA as appropriate)

**T<sub>0</sub> = 60°C** - indicates a maximum operational temperature of 60°C (140°F)

**p<sub>0</sub> = 1.1 bar** - indicates a maximum operational pressure of 1.1 bar (15.9 PSIA)

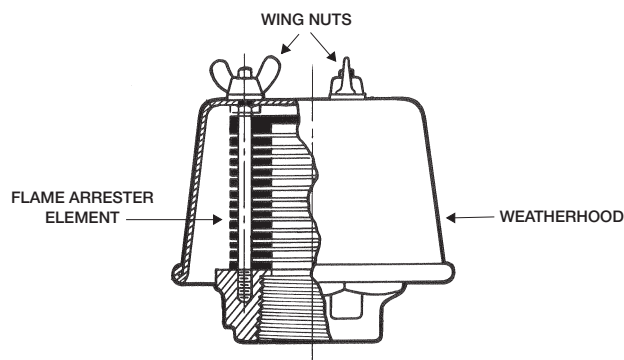

## INSTALLATION PROCEDURE:

1. Check carefully to insure that no packing materials remain on or inside the arrester housing or element.
2. Make sure that the wing nuts mounting the weatherhood to the housing are hand tightened securely.
3. Mount the arrester to the appropriate end-of-line, outlet connection using thread sealant or gasket compatible with service conditions.
4. Arrester should be located at least 0.3 metres (1 foot) from equipment or structure that could impede access to the arrester or impair flow through the device.

## MAINTENANCE:

Protectoseal recommends that our products be inspected and maintained according to the normal maintenance schedule of the facility. At a minimum, maintenance should be conducted annually. More frequent maintenance may be required, and should be scheduled, for unusual service conditions.

**CAUTION: When maintaining any Protectoseal device, the legal, corporate and advisory safety regulations and procedures appropriate for the specific installation site must be fully understood and followed.**

**CAUTION: Tank vapor space pressure or vacuum should be relieved before any maintenance operations are undertaken.**

## MAINTENANCE PROCEDURE:

1. Loosen the wing nuts on the weatherhood. Remove the weatherhood to expose the flame arrester element.
2. The arrester element assembly consists of a series of circular plates, separated by precise embossed teats or spacers.
3. Inspect the arrester assembly. The passages between the individual plates should be even and clear of debris. Blow out any loose dirt or foreign material. If necessary, the arrester assembly may be removed from the tank and immersed in a suitable solvent to remove gums and deposits.

**CAUTION: Do not remove plates from stud. Do not bend plates. Contact Protectoseal if any questions arise.**

4. If plates are damaged or if spacing between plates is uneven, the arrester should be removed from service immediately and replaced.
5. Reinstall weatherhood and secure by hand tightening the wing nuts.



225 Foster Ave., Bensenville, IL 60106-1690  
P 630.595.0800 F 630.595.8059  
info@protectoseal.com www.protectoseal.com

## The Protectoseal Company EC Declaration of Conformity

**Manufacturer:** The Protectoseal Company  
225 Foster Avenue  
Bensenville, IL 60106  
USA

**Quality Assurance Notification Certificate Number:**  
SIRA 10 ATEX M458 issued by  
SIRA Certification Service  
(Notified Body No. 0518)  
Rake Lane  
Eccleston, Chester, CH4 9JN, UK

---

The Protectoseal Company herewith declares that the equipment detailed below is in conformity with the applicable provisions of the ATEX Directive 94/9/EC and has been found to comply with the Essential Health and Safety Requirements relating to the design and construction of equipment intended for use in potentially explosive atmospheres given in Annex II to the Directive.

**Equipment: Type 670E Range of End-of-Line Flame Arresters**

EC Type Examination Certificate #SIRA 09ATEX9196X issued by Sira Certification Service (address as listed above) – Notified Body No. 0518, in accordance with Article 9 of Directive 94/9/EC.

Applied Standards/Marking: EN 12874: 2001  
ISO 16852:2008

Ex II IIA, IIB3

CE 0518

Thomas C. Piotrowski  
Vice President – Engineering  
Document Number: SPEC-670E Revision: 0  
Issue Date: July 1, 2010



**SERIES  
670E**

- Sizes DN 25 (1") through DN 150 (6")
- Type Approved according to ATEX Directive 94/9/EC, Standards EN 12874 and ISO 16852
- Suitable for use with Explosion Groups IIB3 or IIA (NEC Groups C or D)
- Parallel plate-type flame arrester
- Operating temperatures up to +60°C (140°F)
- Available with threaded (FNPT) or flanged (DIN, ANSI) connections
- Easy inspection and maintenance
- Weatherhood protects against environmental conditions
- Available in Aluminum, Ductile Iron, Steel and Stainless Steel



### OBJECTIVE

The Series 670E Flame Arresters are designed to provide flame stopping protection for a tank's vapor space when mounted to the end of a tank nozzle leading directly to atmosphere. Maximum operating pressure is 1.1 bara (15.9 PSIA). The arresters prevent a flame front generated by an unconfined deflagration occurring outside the tank from propagating into the vapor space. Arresters are not for use in stabilized burning situations.

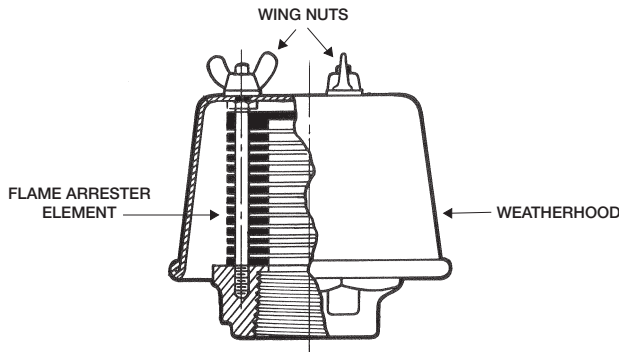

### VAPOR GROUPS

The arresters as designated by model number, are intended for use with vapors equivalent to International Electrotechnical Commission Explosion (IEC) Groups IIB3 or IIA, National Electric Code (NEC) Group C or D.

### TECHNIQUE

The arrester is mounted on the end of a vent pipe from the tank. Vapors are allowed to escape into the atmosphere and air can be drawn into the tank through the specially designed flame arrester grid assembly. If an ignition source outside the tank is encountered, the flame arrester provides protection for the tank contents.

### SPECIAL FEATURES

**Easy Inspection, Installation and Maintenance.** Design and light weight of unit permit easy, convenient handling for inspection, installation and maintenance. The weatherhood is readily removable by loosening just a few wing nuts.

**Automatic Condensate Drainage.** Vertically mounted, circular plate-type flame arrester is employed for self-drainage of condensate. This prevents accumulation of condensate subject to freezing and consequent clogging of the arrester under low temperature conditions.

**Positive Flame Arresting.** The Series 670E employs a precisely-spaced, circular plate type flame arrester to protect tank contents by preventing the propagation of fire into the tank. Precision embossings or spacers provide correct gaps for flame arresting function. Plates are fabricated from heavy gauge stainless steel to resist distortion and bending.

**Sizes Available.** DN 25 (1"), DN 50 (2"), DN 80 (3") and DN 100 (4") and DN 150 (6"). Please refer to dimension chart on reverse for flange connection options.

**Test Lab Listings.** Type Approved according to ATEX Directive 94/9/EC, Standards EN 12874 and ISO 16852. Refer to Protectoseal Series 670/6670 for Underwriters Laboratories (UL) Listed arresters.

**PRO-FLOW III® Sizing and Selection Software.** Use PRO-FLOW III® to calculate flame arrester flow requirements in accordance with API 2000, ISO 28300, NFPA 30 and OSHA 1910.106.

**Quality Assurance.** Each unit is inspected to meet Protectoseal's high standards prior to shipment.

### CONSTRUCTION

A comprehensive range of materials is offered as shown in the chart below.

#### Available Options.

- Material certifications for castings

Series	Body	Hood	Nipple/Flange	Flame Arrester Grid Assembly
A670E	Aluminum	316 S.S.	Aluminum	316 S.S.
C670E	Ductile Iron	316 S.S.	Steel	316 S.S.
F670E	316 S.S.	316 S.S.	316 S.S.	316 S.S.
S670E	Steel	316 S.S. <sup>1</sup>	Steel	316 S.S.

*Please refer to charts on reverse for ordering options. Note 1: Hood on 6" size is constructed of Steel.*

## DN 25 (1"), DN 50 (2"), DN 80 (3") & DN 100 (4") Sizes FNPT or Nipple and Flange Connection

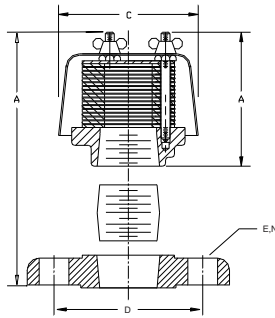

Suitable for use with International Electrotechnical Commission (IEC) Groups IIB3 or IIA (NEC Groups C or D), as designated by model number

Looking for a UL Listed Group D Arrester?

See Series No. 670/6670

## DN 150 (6") Size Flange Connection

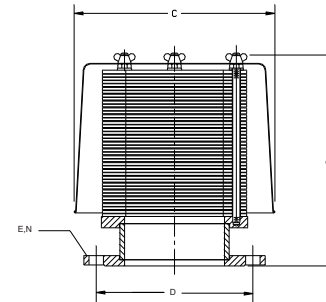

### SERIES 670E PART NUMBERING SYSTEM

DN 25 (1"), DN 50 (2"), DN 80 (3") & DN 100 (4") Sizes									
DIGIT #	1	2	3	4	5	6	7	8	9
1	Material	A	Aluminum Body, 316 S.S. Element & Hood						
		C	Ductile Iron Body, 316 S.S. Element & Hood						
		F	316 S.S. Body, Element & Hood						
		S	Steel Body, 316 S.S. Element & Hood						
2 & 3	Series No.	67	End-of-Line Deflagration Flame Arrester						
		4	Size	1	DN 25 (1")				
2	DN 50 (2")								
3	DN 80 (3")								
4	DN 100 (4")								
5	Type	E							
6	Connection	1	FNPT						
		2	ANSI 125# FF Flange (Aluminum)						
			ANSI 150# RF Flange (Other Materials)						
		3	DIN PN 16 FF Flange (Aluminum)						
7	Flange / Nipple	0	None (FNPT Connection)						
		1	316 S.S. (Use with Prefix "F")						
		2	Steel (Use with Prefix "C" or "S")						
		3	Aluminum (Use with Prefix "A")						
8		-							
9	Vapor Group	C	Explosion Group IIB3 (NEC Group C)						
		D	Explosion Group IIA (NEC Group D)						

DN 150 (6") Size									
DIGIT #	1	2	3	4	5	6	7	8	9
1	Material	A	Aluminum Body, 316 S.S. Element & Hood						
		F	316 S.S. Body, Element & Hood						
		S	Steel Body & Hood, 316 S.S. Element						
2 & 3	Series No.	67	End-of-Line Deflagration Flame Arrester						
4	Size	6	DN 150 (6")						
5	Type	E							
6	Connection	1	ANSI 125# FF Flange (Aluminum)						
			ANSI 150# RF Flange (Other Materials)						
		2	DIN PN 16 FF Flange (Aluminum)						
7	Flange / Nipple	1	316 S.S. (Use with Prefix "F")						
		2	Steel (Use with Prefix "C" or "S")						
		3	Aluminum (Use with Prefix "A")						
8		-							
9	Vapor Group	C	Explosion Group IIB3 (NEC Group C)						
		D	Explosion Group IIA (NEC Group D)						

#### PART NO. EXAMPLE:

Digit #:	1	2	3	4	5	6	7	8	9
	F	6	7	2	E	3	1	-	C

Description: Body, Element & Hood - 316 S.S.  
Size - DN 50 (2")  
Connection - DIN PN 16 RF Flange  
Flange / Nipple - 316 S.S.  
Vapor Group IIB3 (NEC Group C)

### DIMENSIONS

(Please refer to numbering system above to complete Part No. NOTE: Dimensions shown are for reference only, contact Factory for certified drawings.)

Part No.	Connection			Ht	Dia	B.C	Dia.	Holes	Type
	FNPT	ANSI	DIN 16 PN	A	C	D	E	N	Approval
1 671E10-9	1"	-	-	73mm (2.88")	73mm (2.88")	-	-	-	
1 671E2 7-9	-	1"	-	112mm (4.4")	73mm (2.88")	80mm (3.13)	16mm (.63")	4	
1 671E3 7-9	-	-	DN 25	112mm (4.4")	73mm (2.88")	85mm (3.35")	14mm (.55")	4	
1 672E10-9	2"	-	-	117mm (4.63")	150mm (5.88")	-	-	-	
1 672E2 7-9	-	2"	-	178mm (7")	150mm (5.88")	120mm (4.75")	19mm (.75")	4	ATEX Directive
1 672E3 7-9	-	-	DN 50	178mm (7")	150mm (5.88")	125mm (4.9")	18mm (.72")	4	94/9/EC
1 673E10-9	3"	-	-	203mm (8")	150mm (5.88")	-	-	-	Standards
1 673E2 7-9	-	3"	-	251mm (9.88")	150mm (5.88")	152mm (6")	19mm (.75")	4	EN 12874 &
1 673E3 7-9	-	-	DN 80	251mm (9.88")	150mm (5.88")	160mm (6.3")	18mm (.72")	8	ISO 16852
1 674E10-9	4"	-	-	187mm (7.38")	184mm (7.25")	-	-	-	
1 674E2 7-9	-	4"	-	238mm (9.38")	184mm (7.25")	191mm (7.5")	19mm (.75")	8	
1 674E3 7-9	-	-	DN 100	238mm (9.38")	184mm (7.25")	180mm (7.09")	18mm (.72")	8	
1 676E1 7-9	-	6"	-	330mm (13")	314mm (12.38")	241mm (9.5")	22mm (.87")	8	
1 676E2 7-9	-	-	DN 150	330mm (13")	314mm (12.38")	240mm (9.45")	22mm (.87")	8	

Superscripted numbers refer to digits as indicated in the "Part Numbering System" chart.



225 Foster Ave., Bensenville, IL 60106-1690  
P 630.595.0800 F 630.595.8059  
info@protectoseal.com www.protectoseal.com