

**CAUTION:**

If any questions arise concerning the proper installation or maintenance of our products, please contact Protectoseal or one of our Authorized Representatives.

When installing any Protectoseal device, the legal, corporate and advisory safety regulations and procedures appropriate for the specific installation site must be fully understood and followed.



**NOTE 1:** Protectoseal arresters are passive devices with no moving parts. No adjustment, modification or calibration of the device is required.

**MAINTENANCE:**

Protectoseal recommends that our products be inspected and maintained according to the normal maintenance schedule of the facility. At a minimum, maintenance should be conducted annually. More frequent maintenance may be required, and should be scheduled, for unusual service conditions.

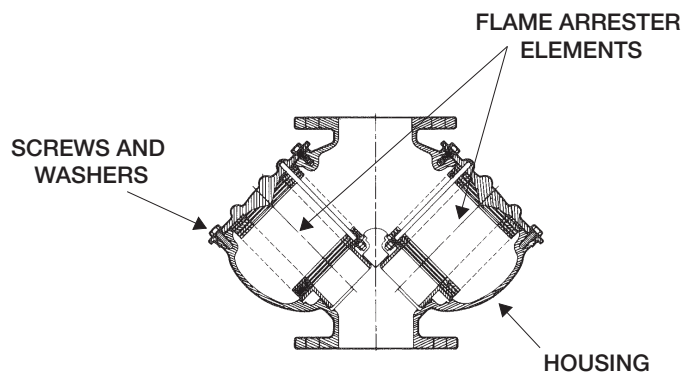

**CAUTION:** When maintaining any Protectoseal device, the legal, corporate and advisory safety regulations and procedures appropriate for the specific installation site must be fully understood and followed.

**CAUTION:** Tank vapor space pressure or vacuum should be relieved before any maintenance operations are undertaken.

**NOTE 1:** In normal service, it is suggested that the arrester be inspected at each regularly scheduled facility maintenance period or, at a minimum, annually.

**NOTE 2:** The arrester should be inspected if excessive pressure drop, at some known flow rate, is encountered.

**NOTE 3:** The arrester should be inspected immediately if a flame front is encountered.

**INSTALLATION PROCEDURE:**

1. Remove all packing materials and flange protectors from the arrester. Check inside the arrester housings for loose packing materials.
2. The arrester is intended to be mounted to piping and flange connections of a size equivalent to the size of the arrester mounting flanges.
3. The installation of the arrester is by flanged or threaded connection to the pipe work. The arrester should be positioned between its mating flanges with a sealant or gasket appropriate for the service conditions. Flange bolts should be tightened evenly and alternately to provide a secure seat at the gasketed joints. If threaded, tighten using a suitable wrench on the flats of the arrester housing.

**WARNING:** Protectoseal vent line flame arresters should only be installed in accordance with the limitations of a specific device. Verify proper location prior to installation.

## MAINTENANCE PROCEDURE:

1. The arrester is comprised of an arrester element bolted into an arrester housing. It is not necessary to remove the housing from the pipeline for inspection or maintenance.
2. Remove the bolts and lock washers that secure the arrester element into the housing.
3. Tap the edges of the cover lightly to loosen the gasket seal and lift the element assembly from the housing.  
Note: On larger size arresters, a lifting handle may be secured to the V-groove in the cover to facilitate lifting and removal of the element.
4. Inspect the gaskets. Replace if damaged.
5. Inspect the arrester element assembly. The passages between the individual plates should be clear. Blow out any loose dirt or foreign material. If necessary the element assembly may be immersed in a suitable solvent to remove gums and deposits.

The arrester element spacings should be even and consistent. If irregular space is found, the element should be replaced. Contact Protectoseal if any questions arise.

**CAUTION: Do not disassemble the element. Do not remove the plates from studs. Do not bend plates. Contact Protectoseal if any questions arise. Do not use file or sharp tools for cleaning between plates.**

6. Reinstall arrester element and gasket. Tighten bolts on element cover to provide secure gasketed joint.

## All Illustrations Presented From a Top View

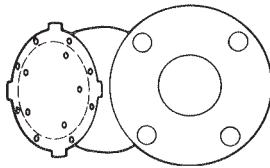

ONE FLAME  
ARRESTER SECTION

4951  
4952F  
4953F  
4956F

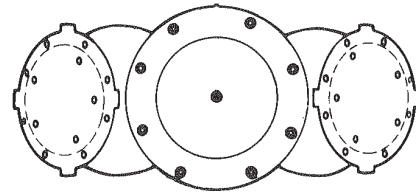

TWO FLAME  
ARRESTER SECTIONS

4954F  
4958F

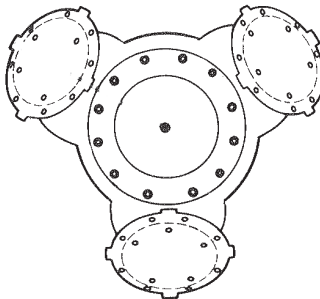

THREE FLAME  
ARRESTER SECTIONS  
4960F

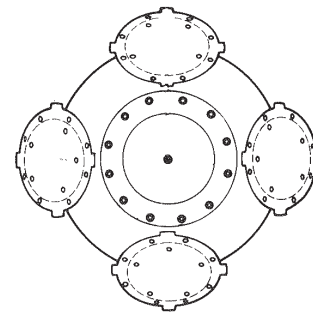

FOUR FLAME  
ARRESTER SECTIONS  
4962BF