

SERIES 30000

Vent-Line / In-Line Crimped Metal Flame Arrester

CAUTION:

If any questions arise concerning the proper installation or maintenance of our products, please contact Protectoseal or one of our Authorized Representatives.

When installing any Protectoseal device, the legal, corporate and advisory safety regulations and procedures appropriate for the specific installation site must be fully understood and followed.



INSTALLATION PROCEDURE:

1. Remove all protective packing from arrester. Check inside arrester housing for loose packing material.
2. The arrester is shipped ready for installation. No adjustments or modifications are required prior to mounting in the piping system.
3. The arrester is intended to be mounted to piping and flange connections of a size equivalent to the size of the arrester mounting flanges.
4. The installation of the arrester is by flanged connection to the pipe work. The arrester should be positioned between its mating flanges and the flange bolts should be tightened alternately and evenly to provide a secure seal at the gasket joints. Torque values for mounting flange fasteners should be as recommended by gasket supplier.

WARNING: Protectoseal vent line flame arresters should only be installed in accordance with the limitations of a specific device. Verify proper location prior to installation.

NOTE: The Protectoseal In-Line / Vent-Line Arrester is a passive device with no moving parts. No adjustment, modification or calibration of the device is required.

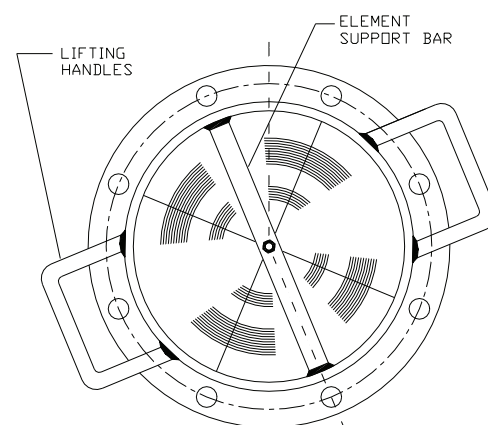
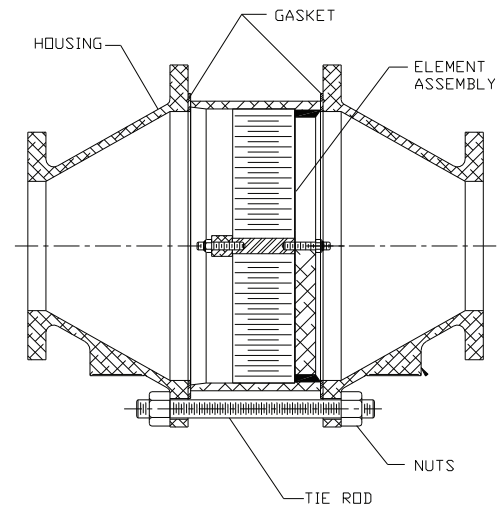

MAINTENANCE:

Protectoseal recommends that our products be inspected and maintained according to the normal maintenance schedule of the facility. At a minimum, maintenance should be conducted annually. More frequent maintenance may be required, and should be scheduled, for unusual service conditions.

CAUTION: When maintaining any Protectoseal device, the legal, corporate and advisory safety regulations and procedures appropriate for the specific installation site must be fully understood and followed.

CAUTION: Tank vapor space pressure or vacuum should be relieved before any maintenance operations are undertaken.

MAINTENANCE PROCEDURE:

INSPECTION INTERVAL:

1. In normal service, it is suggested that the In-Line / Vent-Line Arrester be inspected at each regularly scheduled facility maintenance period or, at a minimum, annually.
2. The Protectoseal In-Line / Vent-Line Arrester should be inspected if excessive pressure drop, at some known flow rate, is encountered.
3. The In-Line / Vent-Line Arrester should be inspected immediately if a flame front is detected.

INSPECTION PROCEDURE:

1. The complete In-Line / Vent-Line Arrester is comprised of an arrester element clamped by means of threaded rods between two element housings.
2. Equipment or structure suitable for supporting the housings and the element should be available prior to disassembly of the device.
3. The weight of the element may be supported by attachment to the element handles.
NOTE: These handles are to be used for lifting of the element only. The handles must not be used to lift or support the weight of the entire arrester.
4. The nuts on all the tie rods should be loosened and all tie rods except those two near the bottom of the element should be removed.
5. Spacer blocks or mechanical spreader tools should be used to separate and secure the housing halves so that the element is free for removal.

6. The element can be lifted for inspection. The gaskets should be inspected for damage and replaced if necessary.
7. The element should be inspected visually for damage to the element winding or the supporting structure. In normal operation, it is unlikely that such damage would be encountered. If the element appears to be damaged, it should be replaced immediately with a new element.
8. The arrester element is comprised of a series of small, triangular shaped openings that traverse the width of the element. Inspection for blockage of these openings can be accomplished by viewing a light source through the element passages.
9. If clogging of the element passages has occurred, the method of cleaning will depend, to some extent, on the materials being handled. Some common cleaning methods include:
 - a) Solvent wash followed by a compressed air blow through
 - b) Compressed air purge
 - c) High pressure steam purge
 - d) High pressure water purge

The element should never be cleaned by the insertion of a sharp tool or probe into the passages. The capability of the arrester to function is based on the integrity of these passages, and damage to them can render the arrester ineffective.

10. The clean element and replacement gaskets should be positioned between the housing halves. The spacer rings may be used as an aide to the proper alignment of the element and housing halves. The tie rods should be reinserted and the nuts should be tightened alternately and evenly to insure a proper gasketed joint. When gaskets are supplied by Protectoseal, the recommended torque values for the tie rod fasteners are:

6" Units - 150 ft-lbs

8" Units - 200 ft-lbs

10" Units -- 350 ft-lbs

12" Units - 450 ft-lbs