

SERIES 25000 & 26000

Bi-Directional Overdriven / Unstable Detonation Flame Arresters



- Sizes 2" (DN 50) through 24" (DN 600)
- Series 25000 for NEC Group D, IEC Group IIA Vapors
- Series 26000 for NEC Group D & C, IEC Groups IIA & IIB3 Vapors
- 150# ANSI standard, DIN PN16 optional
- Interchangeable elements minimize "down-time"
- Low pressure drop, less susceptible to clogging
- Optional flanged or tapped fittings for drains, pressure taps or temperature probes
- Available in Carbon Steel, Stainless Steel & Alloy C276
- Test Lab Listings: Factory Mutual (FM), Underwriters Laboratories (UL, ULC) & United States Coast Guard (USCG)



SERIES 25000 26000

OBJECTIVE

The Protectoseal Series 25000 & 26000 Detonation Arresters are specifically designed to withstand and arrest the high velocity and high pressure flame fronts that may develop in long or complex piping runs such as those encountered in vapor recovery or manifolded tank systems. The arresters provide positive protection against flame transmission through piping systems handling chemical vapor mixtures as referenced in the National Electric Code (NEC) Article 500:

Series 25000 - Suitable for use with Group D chemical vapors, generally equivalent to International Electrotechnical Commission (IEC) Group IIA.

Series 26000 - Suitable for use with Groups C & D chemical vapors, generally equivalent to International Electrotechnical Commission (IEC) Group IIA and IIB3.

TECHNIQUE

When properly specified and installed, the Series 25000/26000 Bi-Directional Detonation Arresters are designed to stop deflagrations (subsonic), stable deflagrations (sonic) and overdriven/unstable (transitional) detonations. The proven ability to withstand this variety of flame fronts is a key characteristic of a detonation flame arrester. These arresters are bi-directional, able to stop a flame approaching from either direction in the piping system.

The severity of the service conditions that the arrester must withstand is demonstrated by the fact that the stable detonation velocity of a flame front in a 4.3% propane/air mixture is 5,800 ft./sec. Instantaneous pressures at the flame front in excess of 500 PSIG have been recorded.

Series 25000/26000 Detonation Arresters are tested to stop and quench such a shock wave while retaining the integrity of both the arresting element and the housing. The size and shape of the openings in the crimped metal element and the length of passage through these openings have been designed to insure the ability of the device to quench multiple stable and overdriven detonations as well as low speed deflagrations and stationary flames, with minimum pressure drop.

LABORATORY TESTING

Approvals: Protectoseal's Detonation Flame Arresters have been thoroughly tested by independent laboratories. Refer to dimension charts for specific test lab listings.

SPECIAL FEATURES

The Series 25000/26000 Detonation Flame Arrester designs utilize crimped metal flame arrester elements. High strength, welded steel housing, hydrostatically tested at 475 PSIG. All welding is performed in accordance with ASME Boiler and Pressure Vessel Code Section IX.

Configuration: Concentric housing, consult factory for availability of eccentric housing.

Sizes Available. 2" (DN 50) through 24" (DN 600) sizes. Consult factory for larger sizes. Flanged to mate with standard flanged 150# ANSI or DIN PN16 bolting specifications. Other drilling patterns are also available upon special request.

PRO-FLOW III® Sizing and Selection Software. Use PRO-FLOW III® to calculate flame arrester flow requirements in accordance with API 2000, ISO 28300, NFPA 30 and OSHA 1910.106.

Optional Fittings: Flanged or tapped fittings may be provided on the arrester housing for drains, pressure taps or temperature probes if required.

Precision Manufacturing: The crimped metal arrester element design allows for flexibility in application. The ability to control the size of the element openings is the key to arresting high velocity and high pressure flame fronts. Manufactured under Protectoseal's ISO 9001 Quality System.

CONSTRUCTION

A comprehensive range of materials is offered as shown in the chart below. Other metals, or options such as steam jacketing, can be furnished upon request.

Series	Housing & Element Housing	Element Winding
C25000 / C26000	Steel	316 S.S.
F25000 / F26000	316 S.S.	316 S.S.
M25000 / M26000	Alloy C276	Alloy C276

All units flanged to mate with 150# R.F. ANSI. DIN flanging optional.

Series No. 25000

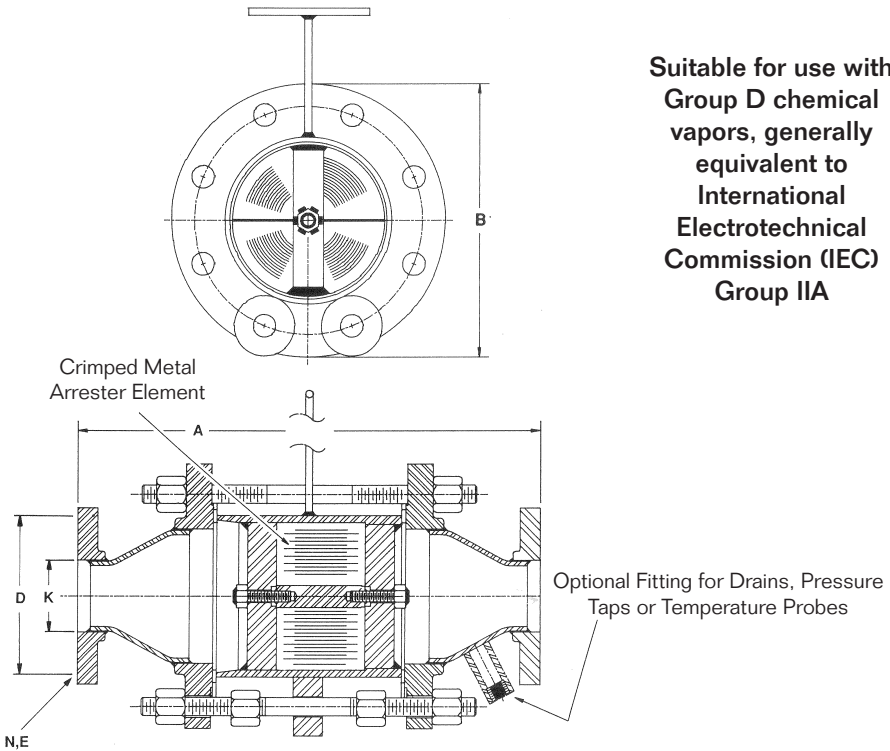

Suitable for use with
Group D chemical
vapors, generally
equivalent to
International
Electrotechnical
Commission (IEC)
Group IIA

(Dimensions shown are for reference only, contact factory for certified drawings.)

DIMENSIONS AND ORDERING INFORMATION (Refer to Materials of Construction chart below to complete Cat. No.)

Cat. No.	Flange Size K	Face to Face A	Dia. B	B.C. D	Dia. E	Holes N	Test Lab Listing*
25002	2"	15 ⁷ / ₈ "	9"	4 ³ / ₄ "	³ / ₄ "	4	UL, ULC, USCG
25003	3"	19 ³ / ₄ "	11"	6"	³ / ₄ "	4	UL, ULC, USCG
25004	4"	21 ¹ / ₂ "	13 ¹ / ₂ "	7 ¹ / ₂ "	³ / ₄ "	8	-
25004A	4"	24 ³ / ₈ "	13 ¹ / ₂ "	7 ¹ / ₂ "	³ / ₄ "	8	UL, ULC, USCG
25006	6"	28 ⁷ / ₈ "	19"	9 ¹ / ₂ "	⁷ / ₈ "	8	UL, ULC, USCG
25008	8"	44"	23 ¹ / ₂ "	11 ³ / ₄ "	⁷ / ₈ "	8	USCG
25010	10"	57 ¹ / ₄ "	27 ¹ / ₂ "	14 ¹ / ₄ "	1"	12	USCG
25012	12"	58"	32"	17"	1"	12	USCG
25014A	14"	73 ⁵ / ₈ "	38 ³ / ₄ "	18 ³ / ₄ "	1 ¹ / ₈ "	12	USCG
25016A	16"	81 ⁵ / ₈ "	38 ³ / ₄ "	21 ¹ / ₄ "	1 ¹ / ₈ "	16	USCG
25018A	18"	83 ¹ / ₈ "	46"	22 ³ / ₄ "	1 ¹ / ₄ "	16	USCG
25020	20"	84"	53"	25"	1 ¹ / ₄ "	20	-
25024	24"	84 ³ / ₄ "	57 ¹ / ₄ "	29 ¹ / ₂ "	1 ³ / ₈ "	20	-

*Test Lab Listings applicable for Series C25000 and F25000 only: UL, Underwriters Laboratories, NEC Group "D" Vapor Equivalent; ULC, Underwriters Laboratories of Canada, NEC Group "D" Vapor Equivalent; USCG, United States Coast Guard, .90MM MESH (Min.).

MATERIALS OF CONSTRUCTION (All units flanged to mate with 150# R.F. ANSI. DIN flanging optional.)

Series. No.	Arrester Housing	Element Housing	Element Winding
C25000	Steel	Steel	316 S.S.
F25000	316 S.S.	316 S.S.	316 S.S.
M25000	Alloy C276	Alloy C276	Alloy C276

Series No. 26000

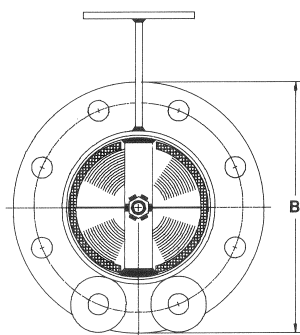

Suitable for use with Group C & D chemical vapors, generally equivalent to International Electrotechnical Commission (IEC) Group IIB3 & IIA

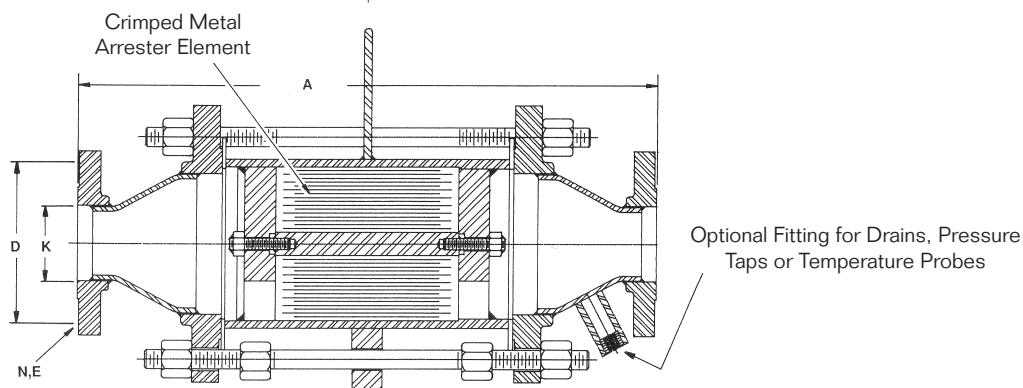

(Dimensions shown are for reference only, contact factory for certified drawings.)

DIMENSIONS AND ORDERING INFORMATION (Refer to Materials of Construction chart below to complete Cat. No.)

Cat. No.	Flange Size K	Face to Face A	Dia. B	B.C. D	Dia. E	Holes N	Test Lab Listing*
26002	2"	18 ⁷ / ₈ "	9"	4 ³ / ₄ "	3/ ₄ "	4	FM, USCG
26003	3"	22 ³ / ₄ "	11"	6"	3/ ₄ "	4	FM, USCG
26004	4"	24 ³ / ₈ "	13 ¹ / ₂ "	7 ¹ / ₂ "	3/ ₄ "	8	FM, USCG
26006	6"	28 ⁷ / ₈ "	19"	9 ¹ / ₂ "	7/ ₈ "	8	FM, USCG
26008	8"	44"	23 ¹ / ₂ "	11 ³ / ₄ "	7/ ₈ "	8	USCG
26010	10"	57 ¹ / ₄ "	27 ¹ / ₂ "	14 ¹ / ₄ "	1"	12	USCG
26012	12"	58"	32"	17"	1"	12	USCG

Consult factory for larger sizes

*Test Lab Listings applicable for Series C26000 and F26000 only:- FM, Factory Mutual Research, NEC Group "C" & Group "D" Vapor Equivalent; USCG, United States Coast Guard, .65MM MESG (Min.).

MATERIALS OF CONSTRUCTION (All units flanged to mate with 150# R.F. ANSI, DIN flanging optional.)

Series. No.	Arrester Housing	Element Housing	Element Winding
C26000	Steel	Steel	316 S.S.
F26000	316 S.S.	316 S.S.	316 S.S.
M26000	Alloy C276	Alloy C276	Alloy C276

PROTECTOSEAL DETONATION ARRESTER APPLICATION WORKSHEET

COMPANY:		DATE:	
PHONE:		ISSUED BY:	
FAX:		ADDRESS:	
E-MAIL:			
PROJECT:			

Please Specify Units of Measurement

SERVICE CONDITIONS

1	Tag Number				
2	Tank Number				
3	Capacity of Tank				
4	Tank Design Pressure				
5	Tank Design Vacuum				
6	Gas / Vapor % or ppm				
	Gas / Vapor % or ppm				
	Gas / Vapor % or ppm				
	Gas / Vapor % or ppm				
	Gas / Vapor % or ppm				
	Gas / Vapor % or ppm				
	Gas / Vapor % or ppm				
7	Specify by Weight or Volume				
8	Molecular Weight Average				
9	Vapor Group NEC or IEC Rating				
10	Flash Point F				
11	Temperature F Operating / Maximum	/	/	/	/
12	Pressure Operating / Maximum	/	/	/	/

DETONATION ARRESTER APPLICATION

13	Deflagrations & Stable Detonations				
14	Deflagrations, Stable & Unstable (Overdriven Detonations)				
15	Distance between Arrester & Ignition Source				
16	List Bends between Arrester & Ignition Source				
17	Additional Information				

FLOW REQUIREMENTS

18	Flow Requirements				
19	Allowable Pressure Drop Across Arrester				

MATERIALS OF CONSTRUCTION

20	Body Material				
21	Arrester Element Winding				
22	Arrester Element Housing				

DESIGN TYPE

23	Vertical or Horizontal Installation				
24	Size: Inlet / Outlet	/	/	/	/
25	Connection Type				
26	Drain Plugs (qty / size/ NPT or flanged)				
27	Other Options				

RECOMMENDATION

28	Protectoseal Model Number				
----	---------------------------	--	--	--	--



225 Foster Ave., Bensenville, IL 60106-1690
 P 630.595.0800 F 630.595.8059
 info@protectoseal.com www.protectoseal.com