



ISO 9001



ISO 14001



ELECTRIC ACTUATOR RAM HQ - SERIES

**Weather proof
Explosion proof
Special options**

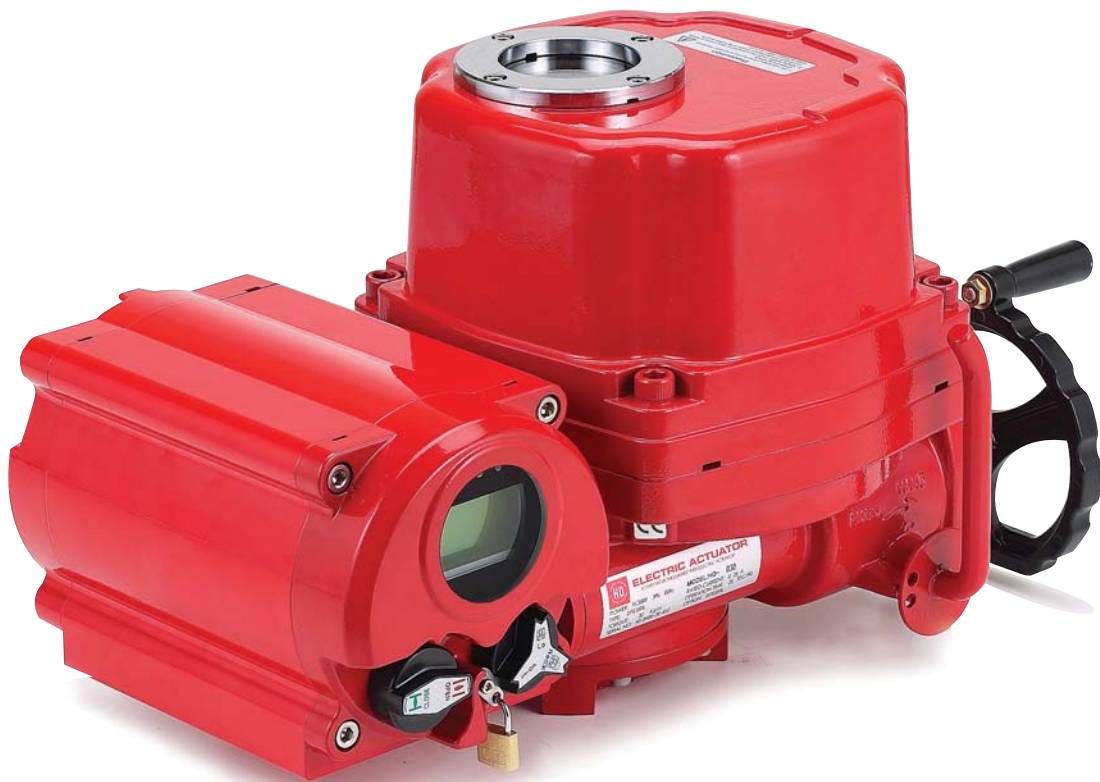

세계일류상품



RAM UNIVERSAL LTD.

Unit 20, Swannington Road
Broughton Astley
Leicestershire, LE9 6TU
T: 01455 285428 | ramuniversal.co.uk

Valve automation leader HKC

HCAG-HQ-15 Rev.0

Research and Development Center

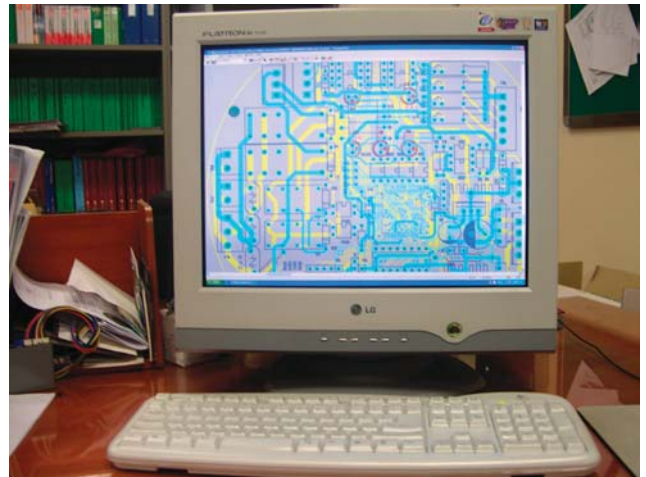

Training & Education Center

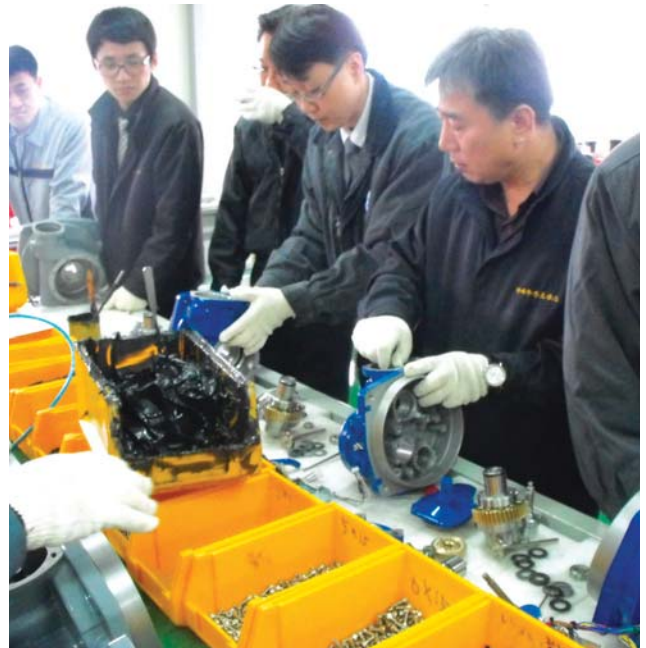

Test Equipment



Aluminum Die-Cast Foundry



Programmable Machining Center

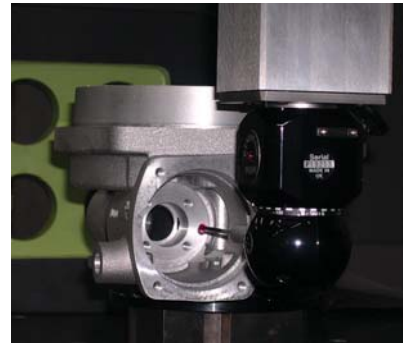

Assembly



Construction

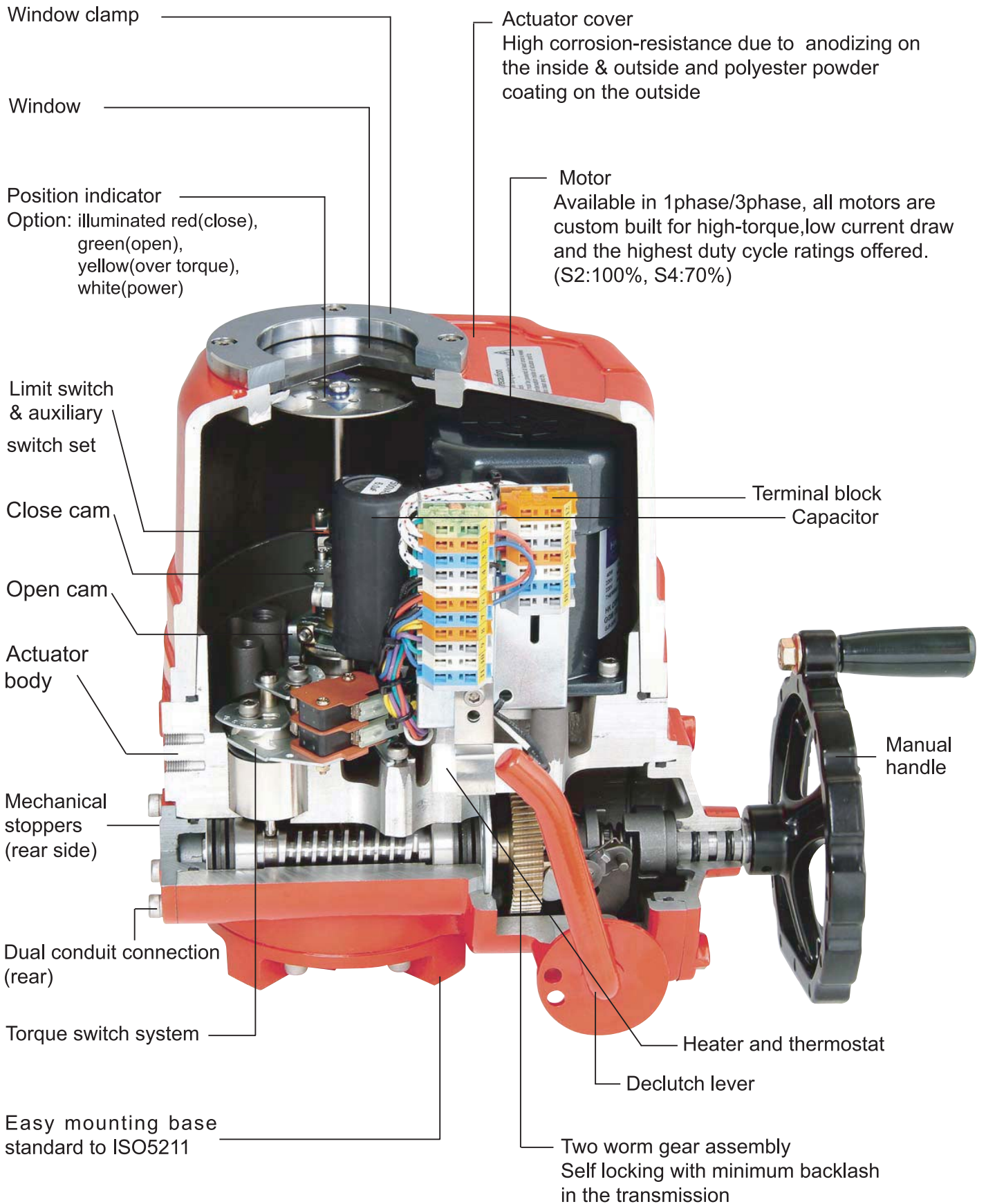

Standard Configuration



Terminal block

- Enough number of terminal strips for customer's convenience
- Proven reliability and tight wiring connection.
- Stripped length: 8-9 mm / 0.33 in(2.5mm²)
- Terminal dimensions: 10 × 22 × 32mm



Heater

- Ceramic housing with thermostat to prevent over heat comparing with set temperature.
- No risk of electricity leakage.

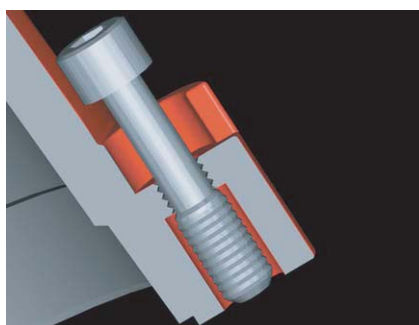

Captive cover bolt

- Cover bolts are specially designed to prevent losing it during maintenance or installation.
- All external bolts are stainless steel for rust prevention.



Indicator sustained by spring

- Direction of visual indicator is set by factory.
- In case of changing it's direction, just grip the indicator plate and change the position.
- Spring beneath indicator plate sustains the set position unchanged.
- No need to loose screw and tight it again !

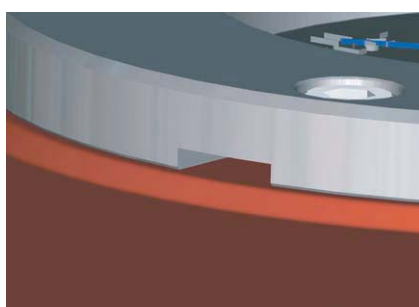

Slot on window cover for draining rainwater

- Rainwater inside of window cover may affect the sealing of window.
- To prevent this, drain slot is useful to prevent this effect.

Electric Actuator HQ Series

HQ Series



Performance

HQ (MODEL)	Max. output torque	Operating time(sec.) 50/60Hz	Mounting bore size	Rated current (A), (50/60Hz)								Duty rate	No. of handle turn	Weight
				DC	AC, 1 phase, 50/60 Hz				AC, 3 phase, 50/60 Hz					
					24	100	110	200	220	380	440			
HQ-008	8	16/13	20	3.7	1.3/1.3	1.2/1.1	0.7/0.6	0.6/0.6	0.2/0.3	0.6/0.4	NA	70	10	7
HQ-010	10	20/17	20	4.0	1.3/1.3	1.2/1.1	0.7/0.7	0.7/0.6	0.2/0.3	0.6/0.4	NA	70	10	7
HQ-015	15	25/21	22	5.3	2.4/2.2	2.1/2.0	1.1/1.1	1.0/1.0	0.6/0.4	0.6/0.4	0.6/0.4	70	11	17
HQ-020	20	25/21	22	6.5	2.5/2.3	2.2/2.1	1.2/1.2	1.1/1.1	0.7/0.5	0.6/0.4	0.6/0.4	70	11	17
HQ-030	30	31/26	35	8.6	2.3/2.7	2.1/2.4	1.1/1.4	1.0/1.3	0.6/0.5	0.4/0.3	0.4/0.3	70	13.5	22
HQ-050	50	31/26	35	12.8	3.6/4.6	3.3/4.2	1.9/2.1	1.7/1.9	0.9/0.8	0.8/0.5	0.7/0.5	70	13.5	23
HQ-060	60	31/26	35	NA	3.8/4.9	3.4/4.4	2.1/2.3	1.9/2.0	1.0/0.9	1.4/0.9	1.3/0.9	70	13.5	23
HQ-080	80	37/31	45	NA	6.0/6.3	5.4/5.7	2.9/3.1	2.6/2.8	1.3/1.0	1.7/0.9	1.6/0.9	70	16.5	29
HQ-120	120	37/31	45	NA	7.2/7.6	6.5/6.9	3.1/3.3	2.8/3.0	1.5/1.1	1.8/1.0	1.7/0.9	70	16.5	29
HQ-200	200	37/31 ⁽¹⁾	65	NA	6.0/6.3	5.4/5.7	3.4/3.3	3.1/3.0	1.4/1.0	1.7/1.0	1.6/0.9	50	49.5	75
HQ-300	300	112/93	65	NA	7.2/7.6	6.5/6.9	3.1/3.3	2.8/3.0	1.5/1.1	1.8/1.0	1.7/0.9	50	49.5	75

Note (1) Operating times at 100 & 110 Vac 1 phase of HQ-200 are 112/93 (50/60 Hz) (2) Option Speed & Torque are able to change from standard

Standard Specification

Enclosure	Weatherproof enclosure IP67, NEMA 4, 4X and 6
Power supply	110 / 220V ac 1ph, 380 / 440V ac 3ph 50 / 60Hz, ± 10%
Control power supply	110 / 220V ac 1ph, 50 / 60Hz, ± 10%
Duty cycle(on-off)	S2, 100% Max 30Min
Duty cycle(modulating)	S4, 40~70% Max 300~1600 start/hour (Option :100%)
Motor	Induction motor (Reversible motor)
Limit switches	Open / close, SPDT, 250V ac 16A rating
Additional limit switches	Open / close, SPDT, 250V ac 16A rating (except HQ-008/010)
Torque switches	Open / close, SPDT, 250V ac 16A rating (except HQ-008/010)
Stall protection/operating temp	Built-in thermal protection, open 150°C±5°C / close 97°C±15°C
Travel angle	90° ± 10° (0~110°)
Indicator	Continuous position indicator
Manual override	Declutching mechanism
Self locking	Provided by double worm gearing
Mechanical stopper	2 × external adjustable screws
Space heater	10W(110/220V ac) Anti-condensation
Cable entries	General- PF3/4" x2 Explosion proof : NPT 3/4" x2 or M25x2
Lubrication	Grease moly (EP type)
Terminal block	Spring loaded lever push type
Materials	Steel, Aluminium alloy, Al bronze, Polycarbonate
Ambient temperature	-20°C~+70°C (except option electronic board) (Option :-40°C), Explosion proof : -20~+60°C
Ambient humidity	90% Max RH.(non-condensing)
Anti vibration	X Y Z 10g, 0.2~34Hz, 30minute
External coating	Anodizing treatment before dry powder, Polyester coating

Option Specification

EXTB	Dust ignition proof -20~60°C (Ex tb IIIc 135°C Db)	HQ-series
EXD	Explosion proof enclosure actuator -20°C ~ +60°C (Ex d IIB T4 Gb)	HQ-series
WTA	Watertight enclosure actuator (IP68 10m 72hr)	HQ-series
PIU	Potentiometer unit (0~1k Ω)	HQ-series
PCU	Proportional control unit (input, output 0~10V DC, 4~20mA DC)	HQ-series
ATS	Additional torque switches (SPDT x 2ea 250V AC 10A rating)	except HQ-008/010
LCU-B	Integral control (LCU + IMS + phase protect indicator)	except HQ-008/010
LCU-C	Digital display control (LCU + IMS + auto phase discriminator)	except HQ-008/010
CPT	Current position transmitter (output 4~20mA DC)	HQ-series
EXT	Extension angle 120°, 180°, 270° turn	except HQ-200, 300
RBP	Rechargeable battery backup	HQ-008/010, 015, 020, 030
DCM	DC motor (24V DC)	HQ-008/010, 015, 020, 030
ADCM	Multi AC/DC 24V(integral)	HQ-008/010, 015, 020, 030
LPA	Lever plate actuator	except HQ-008/010
SLU	Signal lamp unit (white-power on, red-open, green-close, yellow-over torque)	except HQ-008/010
FPA1	Fire proofing actuator 1050 \pm 5°C / 50min	Engineering consult in advance
FPA2	Fire proofing actuator 250 \pm 5°C / 150min	Engineering consult in advance
SPD	Surge protection device (Max1.5kW)	

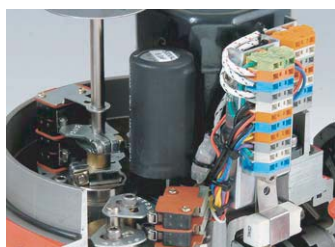

(Standard cam)

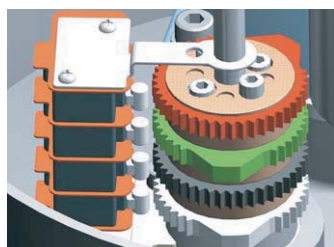

(Cam block)

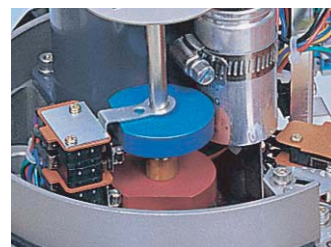

(D-type cam)

- 2 travel limit switches for operation
- 2 auxiliary limit switches as dry contact for customer usage
- Easy setting from upside by two screws for tight lockup
- Each cam be set independently



Proportional Control Unit (PCU)

- Input signal range : 0~10VDC, 1~5VDC, 4~20mA, 20~4mA
- Output signal range : 4~20mA, 0~10VDC
- Adjustable range : Zero 8mA, Open 16mA
- Position conversion accuracy : \pm 0.5~1.5%(depends on installation)



Potentiometer Kit (PIU)

- 0~1k ohm(\pm 0.5%), high resolution



Fire Proofing Actuator (FPA)



Rechargeable Battery Backup

Dimensional Drawing

HQ008, HQ010, HQ015, HQ020, HQ030, HQ050, HQ060, HQ080, HQ120

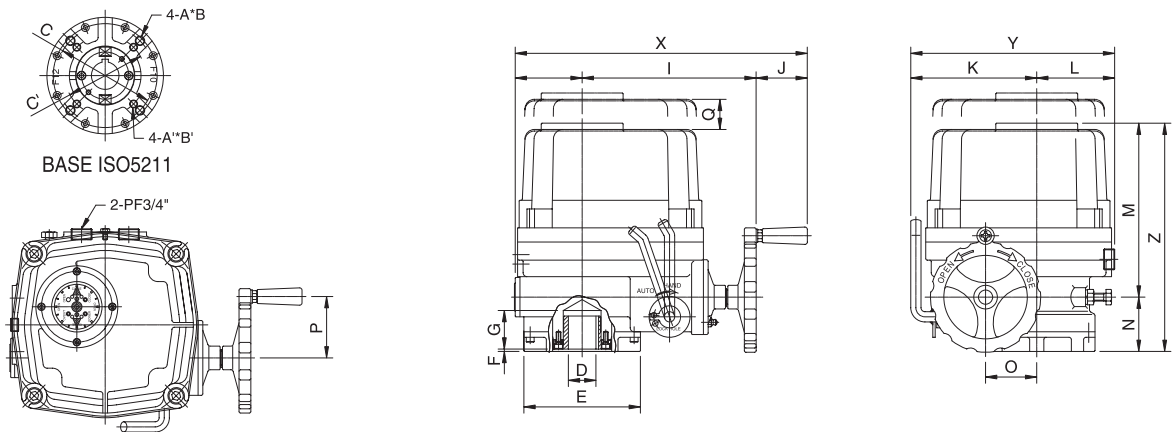

HQ200, HQ300

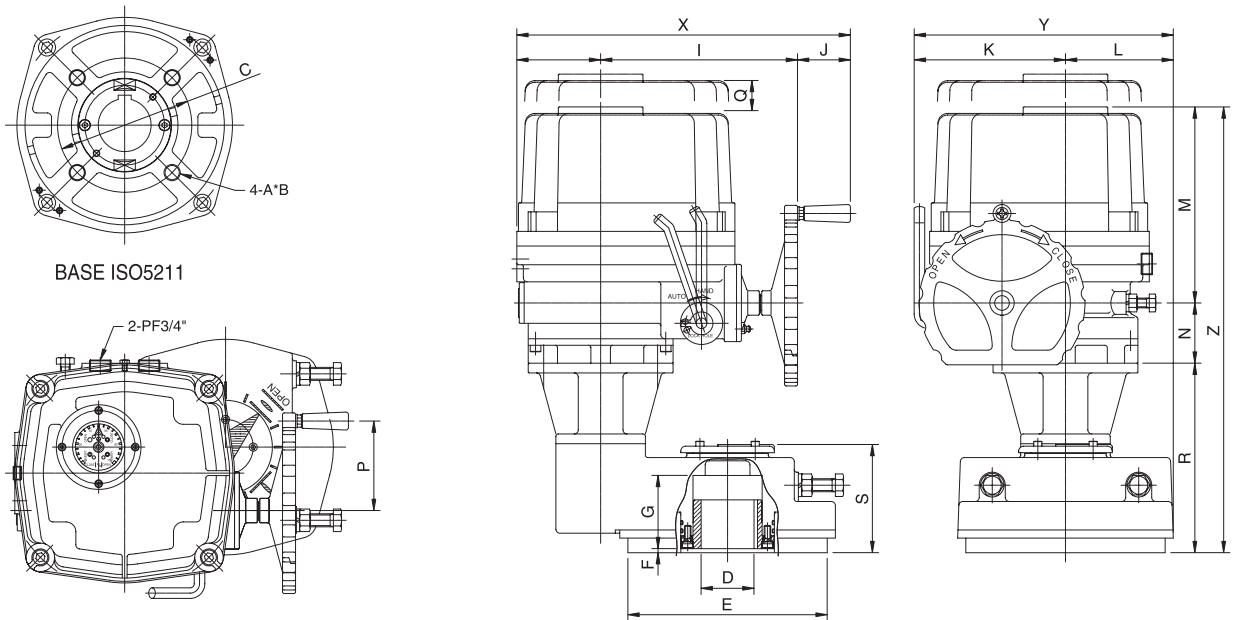

Dimension

unit(mm)

Model	Base ISO 5211	A	D (max)	E	F	G	H	I	J	K	L	M	N	O	P	Q	R	S	X	Y	Z
HQ008	F07	M8	20	88	3	32	50	157	51	100	70	182	53	40	60	120	-	-	258	170	235
	φ 70	12																			
HQ010	F07	M8	20	88	3	32	50	157	51	100	70	182	53	40	60	120	-	-	258	170	235
	φ 70	12																			
HQ015	F07/F10	M8/M10	22	125	3	42	73	200	65	142	87	200	68	54	78	160	-	-	338	229	268
	φ 70 φ102	12/15																			
HQ020	F07/F10	M8/M10	22	125	3	42	73	200	65	142	87	200	68	54	78	160	-	-	338	229	268
	φ 70 φ102	12/15																			
HQ030	F10/F12	M10/M12	35	148	3	49	82	221	65	160	99	221	69	65	78	180	-	-	368	259	290
	φ 102 φ125	15/18																			
HQ050	F10/F12	M10/M12	35	148	3	49	82	221	65	160	99	235	69	65	78	180	-	-	368	259	304
	φ 102/φ125	15/18																			
HQ060	F10/F12	M10/M12	35	148	3	49	82	221	65	160	99	235	69	65	78	180	-	-	368	259	304
	φ 102/φ125	15/18																			
HQ080	F12/F14	M12/M16	45	178	3	57	103	242	65	186	111	256	74	78	110	210	-	-	410	297	330
	φ 125*/φ140	18/24																			
HQ120	F12/F14	M12/M16	45	178	3	57	103	242	65	186	111	256	74	78	110	210	-	-	410	297	330
	φ 125/φ140	18/24																			
HQ200	F14*/F16	M16*/M20	65	245	5	90	103	242	65	186	133	256	74	78	110	210	233	133	410	319	563
	φ 140*/φ165	24*/30																			
HQ300	F14*/F16	M16*/M20	65	245	5	90	103	242	65	186	133	256	74	78	110	210	233	133	410	319	563
	φ 140*/φ165	24*/30																			

※F14” is drilled by request.

Standard Type (1- phase, 50/60Hz)

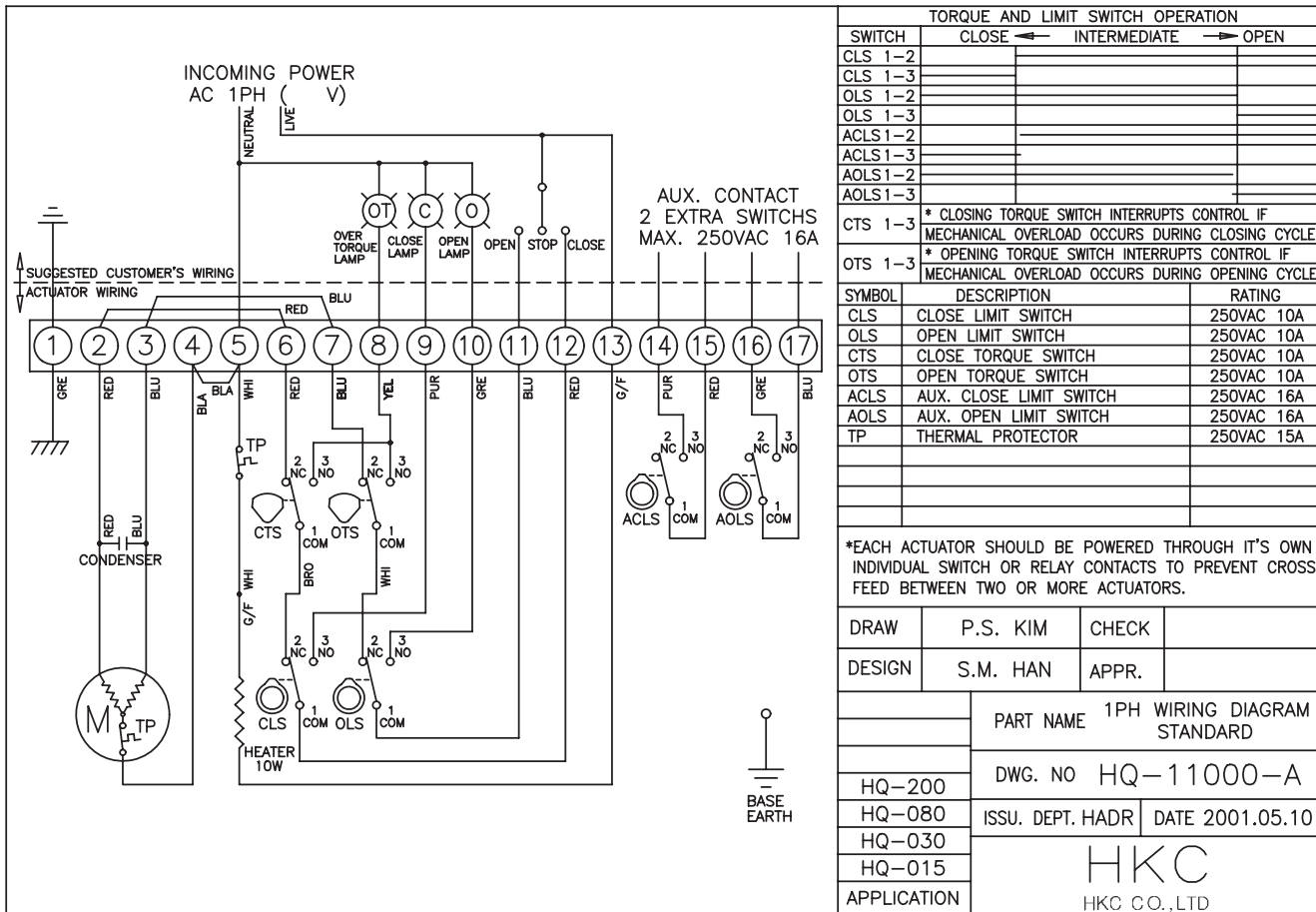

Proportional Type (1- phase, 50/60Hz)

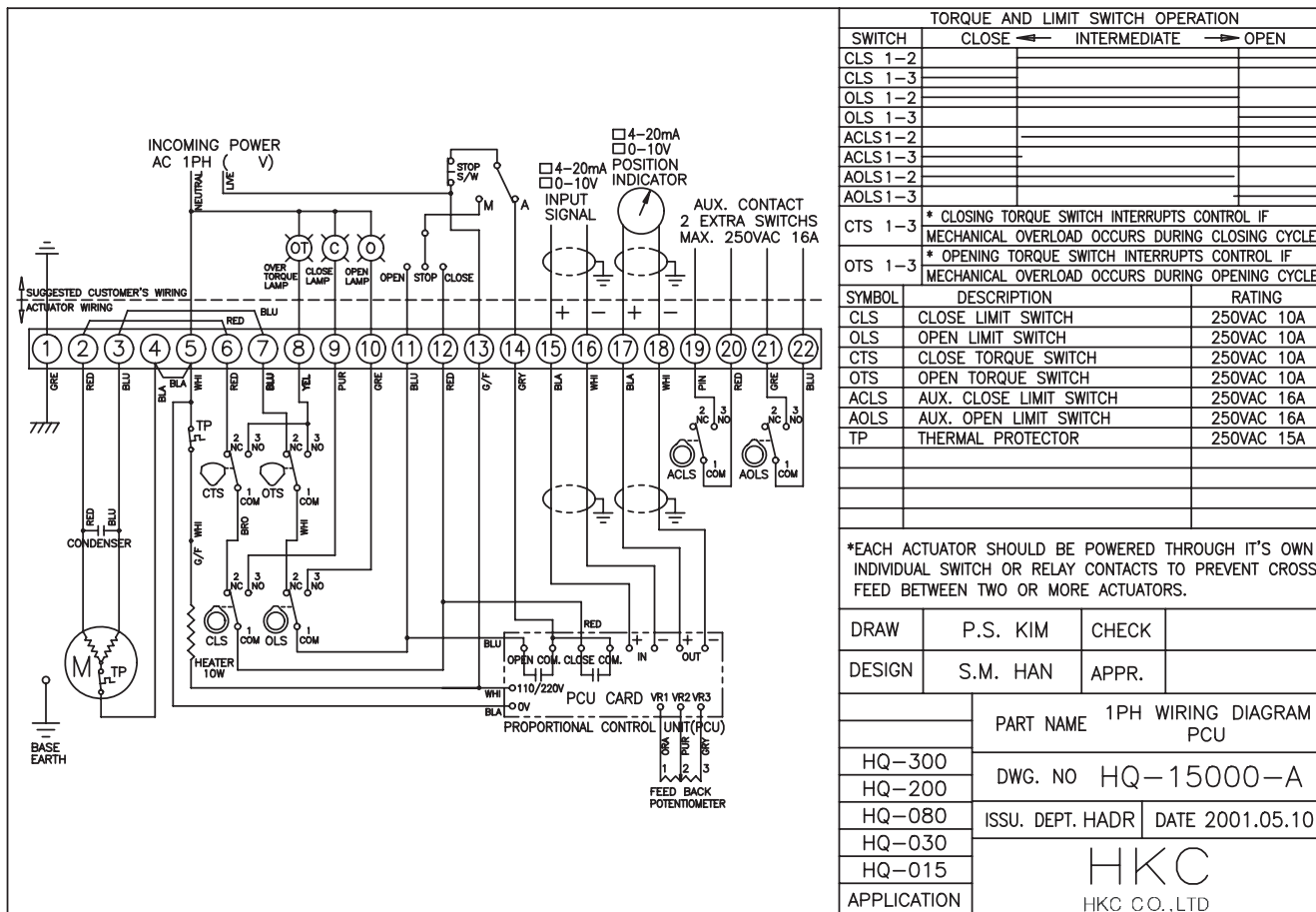

※ Wiring drawings are provided upon request.

LCU-B : Integral Control

- Light, compact & Integrated design (IMS, Local/Remote control)
- Wide range of electric power application
- 1 ϕ AC 110~220V 50/60Hz
- 3 ϕ AC 220V~460V 50/60Hz
- Phase protect monitoring by LED in case of wrong wiring
- Easy application for HQ-series actuators
- Various option available (Duty cycle:70%)



LED lamp signal	
White ○	: Power
Blue ●	: Remote
Yellow ●	: Fault
Red ●	: Open/ Opening
Green ●	: Close/ Closing



LCU-B Wiring (1-phase, 50/60Hz, proportional type)

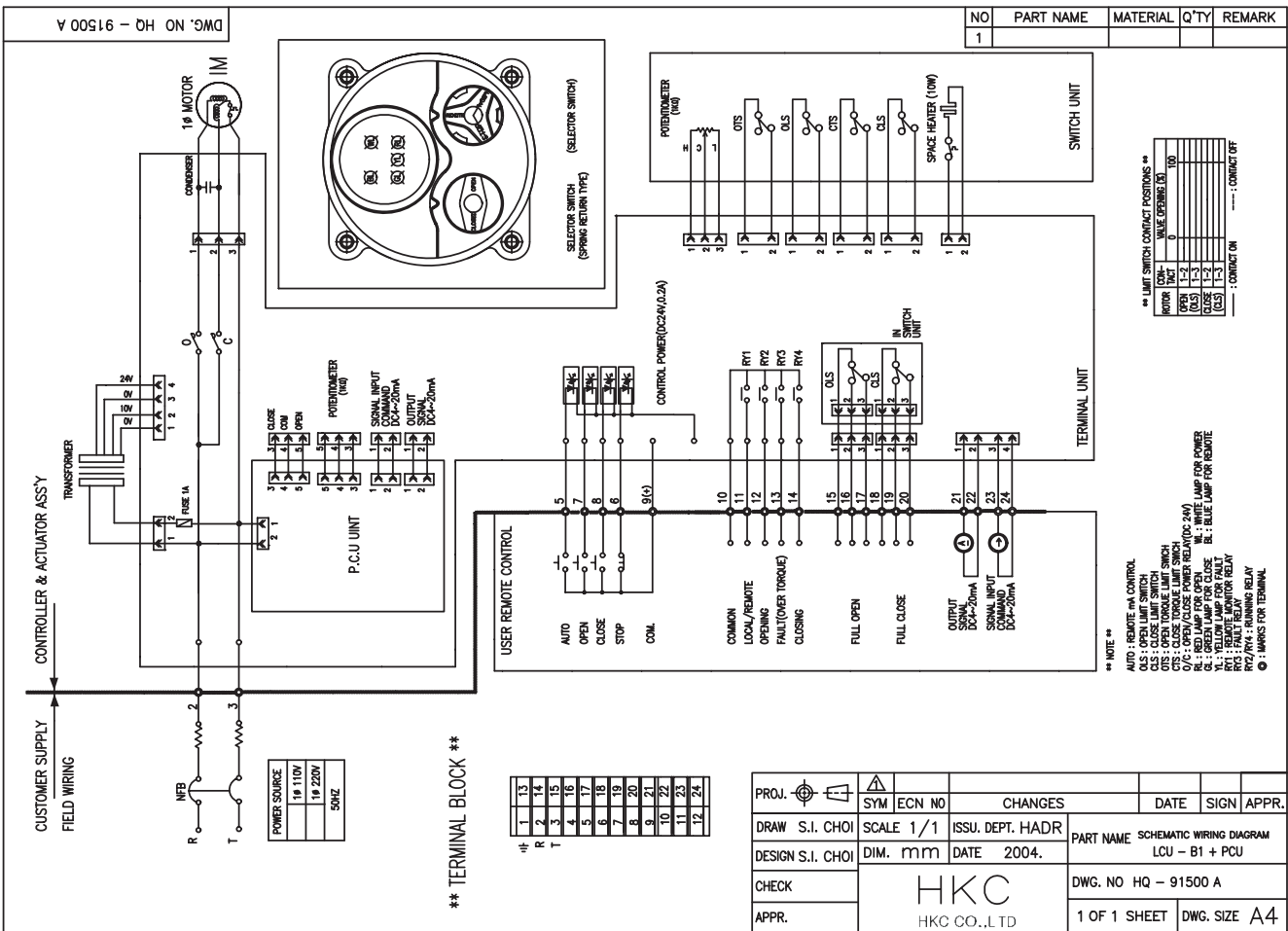

LCU-B Wiring (3-phase, 50/60Hz, on-off type)

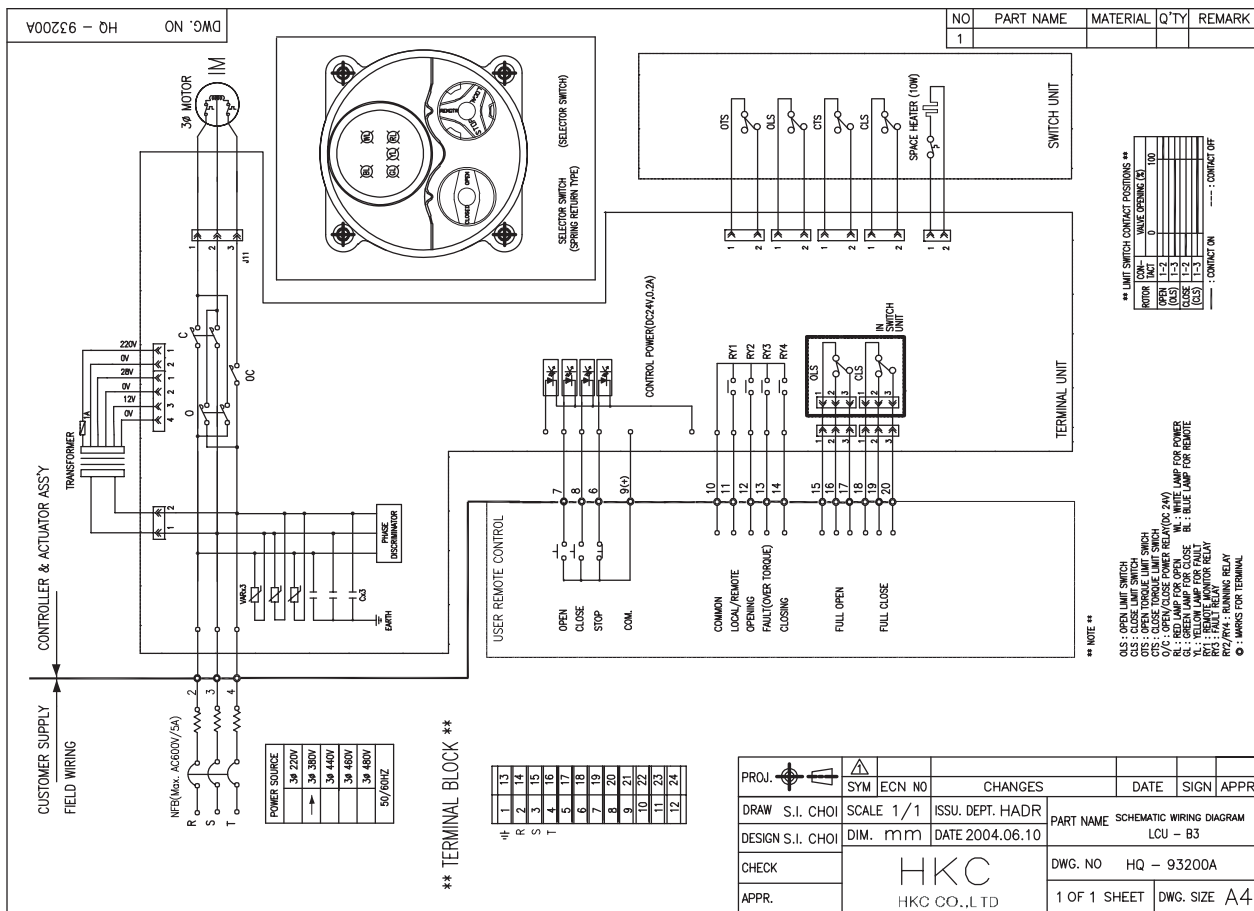

LCU-B Wiring (3-phase, 50/60Hz, proportional type)

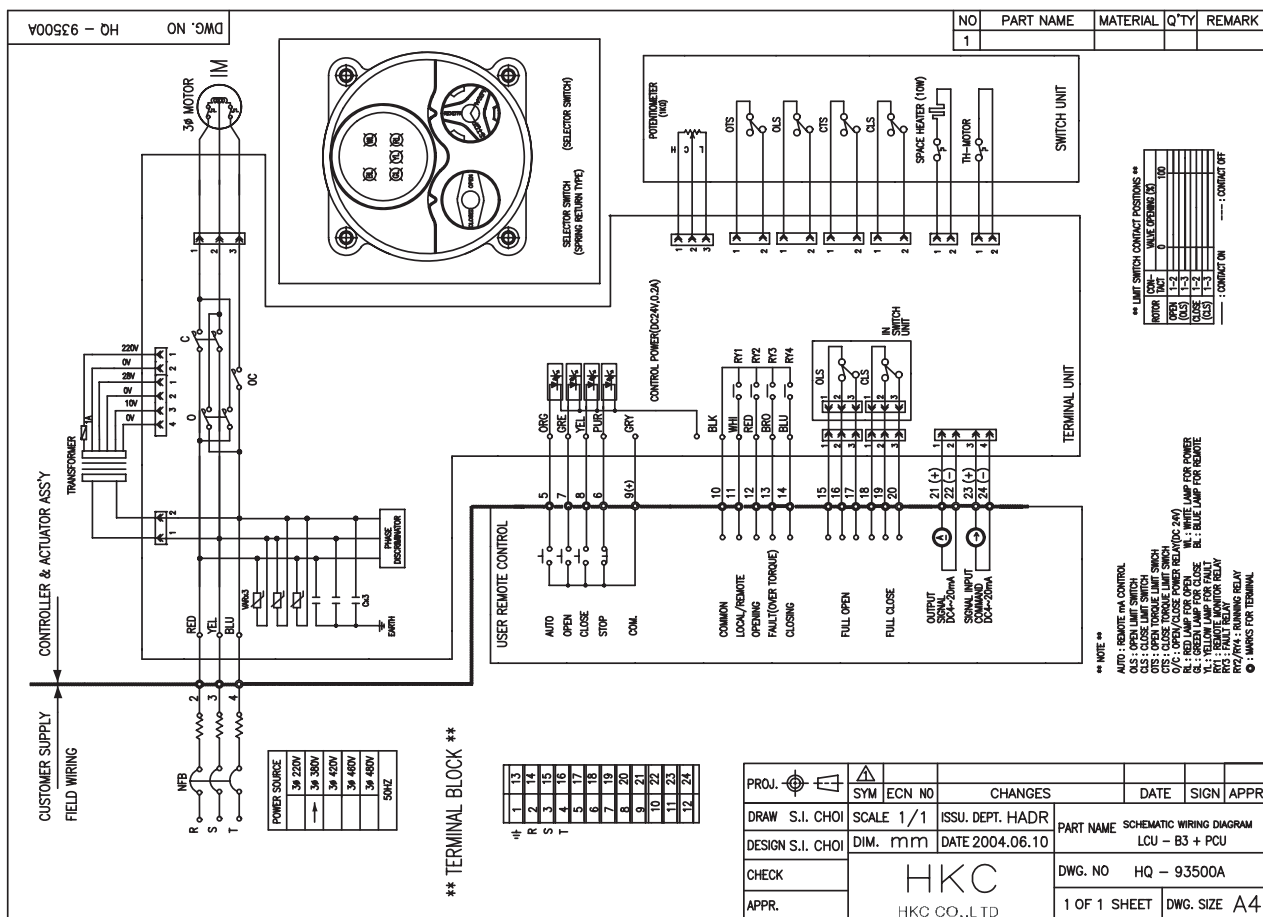

Dimensional Drawing (with LCU-B)

HQ015, HQ020, HQ030, HQ050, HQ080, HQ120

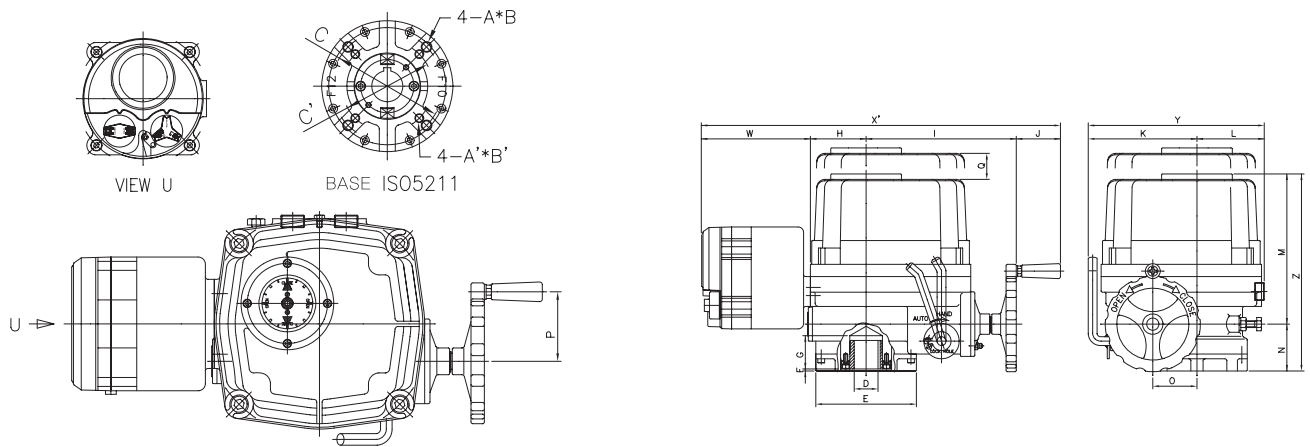

HQ200, HQ300

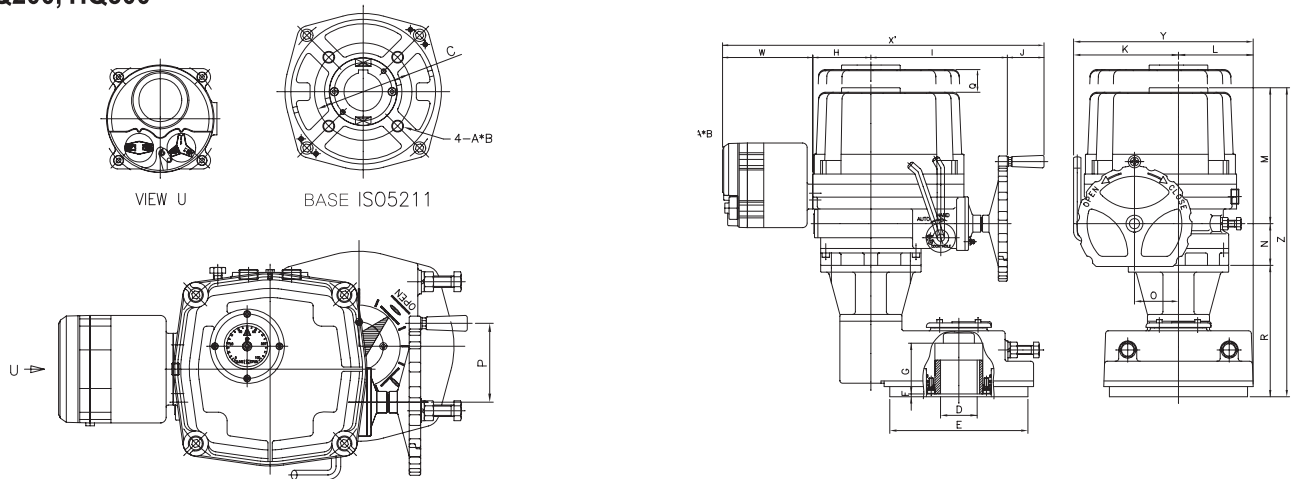

Dimension (with LCU-B)

unit(mm)

Model	Base ISO5211 ØC	A B	D (max)	E	F	G	H	I	J	K	L	M	N	O	P	Q	R	S	W	X	Y	Z
HQ015	F07/F10	MBM10	22	125	3	42	73	200	65	142	87	200	68	54	78	160	-	-	160	498	229	268
	Ø70/Ø102	12/15																				
HQ020	F07/F10	MBM10	22	125	3	42	73	200	65	142	87	200	68	54	78	160	-	-	160	498	229	268
	Ø70/Ø102	12/15																				
HQ030	F10/F12	M10M12	35	148	3	49	82	221	65	160	99	221	69	65	78	180	-	-	160	528	259	290
	Ø102/Ø125	15/18																				
HQ050	F10/F12	M10M12	35	148	3	49	82	221	65	160	99	235	69	65	78	180	-	-	160	528	259	304
	Ø102/Ø125	15/18																				
HQ060	F10/F12	M10M12	35	148	3	49	82	221	65	160	99	235	69	65	78	180	-	-	160	528	259	304
	Ø102/Ø125	15/18																				
HQ080	F12/F14	M12M16	45	178	3	57	103	242	65	186	111	256	74	78	110	210	-	-	160	570	297	330
	Ø125/Ø140	18/24																				
HQ120	F12/F14	M12M16	45	178	3	57	103	242	65	186	111	256	74	78	110	210	-	-	160	570	297	330
	Ø125/Ø140	18/24																				
HQ200	F14*/F16	M16*/M20	65	245	5	90	103	242	65	186	133	256	74	78	110	210	233	133	160	570	319	563
	Ø140*/Ø165	24*/30																				
HQ300	F14*/F16	M16*/M20	65	245	5	90	103	242	65	186	133	256	74	78	110	210	233	133	160	570	319	563
	Ø140*/Ø165	24*/30																				

※ Wiring drawings are provided upon request.

RBP : Rechargeable Battery Backup

- Emergency application when power failed at site
- 1 phase power
- Litium battery
- Indication of battery level
- Automatic recharge
- 5 times operation per hour



LED lamp signal	
White ○	: Power
GBR ●	: Battery level
Blue ●	: Remote
Yellow ●	: Fault
Red ●	: Open/ Opening
Green ●	: Close/ Closing

RBP wiring (1-phase, 50/60Hz, on-off type)

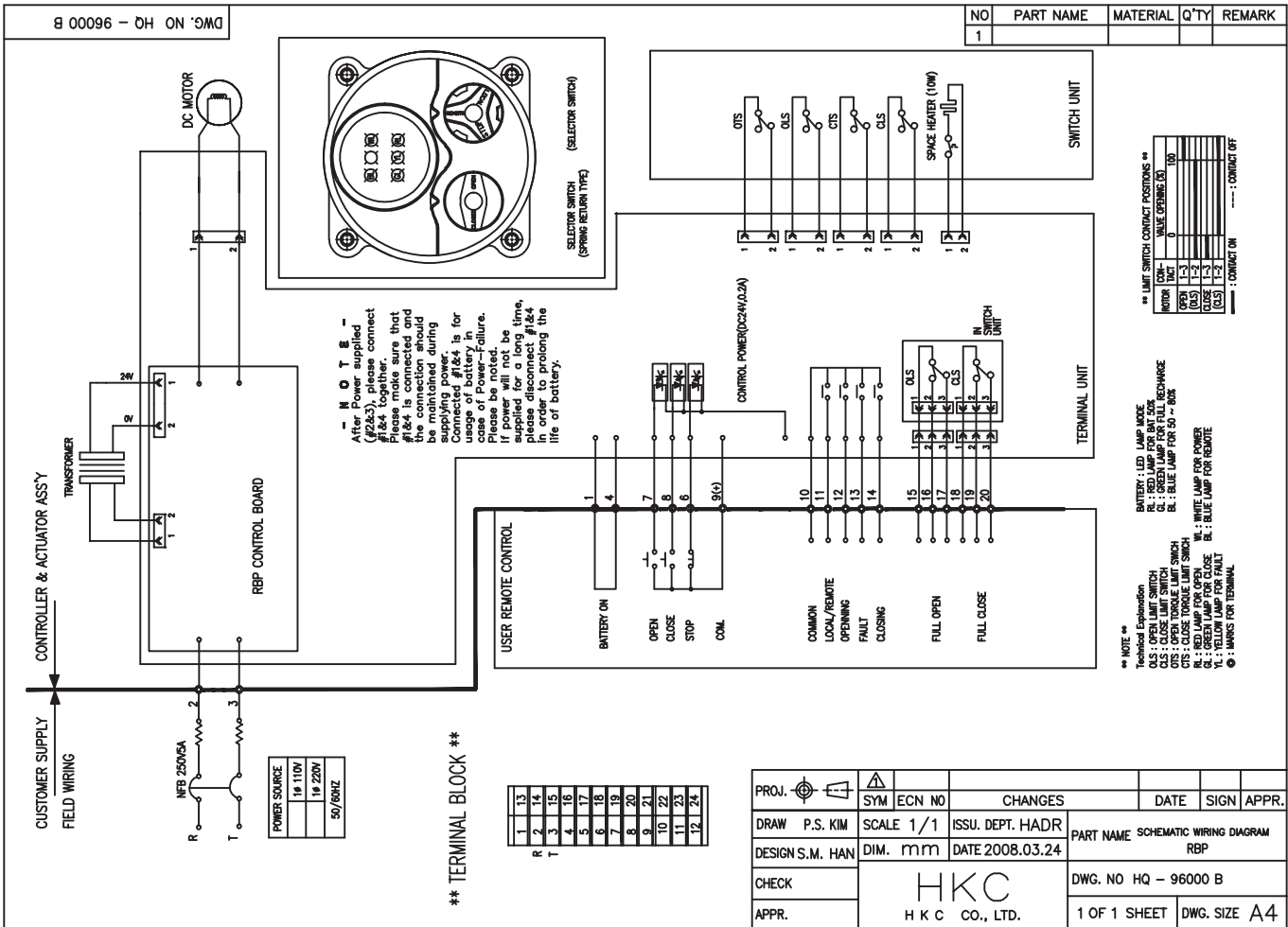

LCU-C : Digital Display Control

- Light, Compact & Integrated design
- Wide range of electric power application
(AC 220V~AC460V/3-phase, No Fuse Break Max.AC600V/5A)
- Built-in auto phase discriminator (Easy & convenient wiring)
- Digital indicator with number, bar graph & literature
- Seperate terminal chamber
- (Reliable against water, vibration, temp, etc)
- Easy application for HQ-series actuators
- Various option available



LCU-C Wiring (3-phase, 50/60Hz, proportional type)

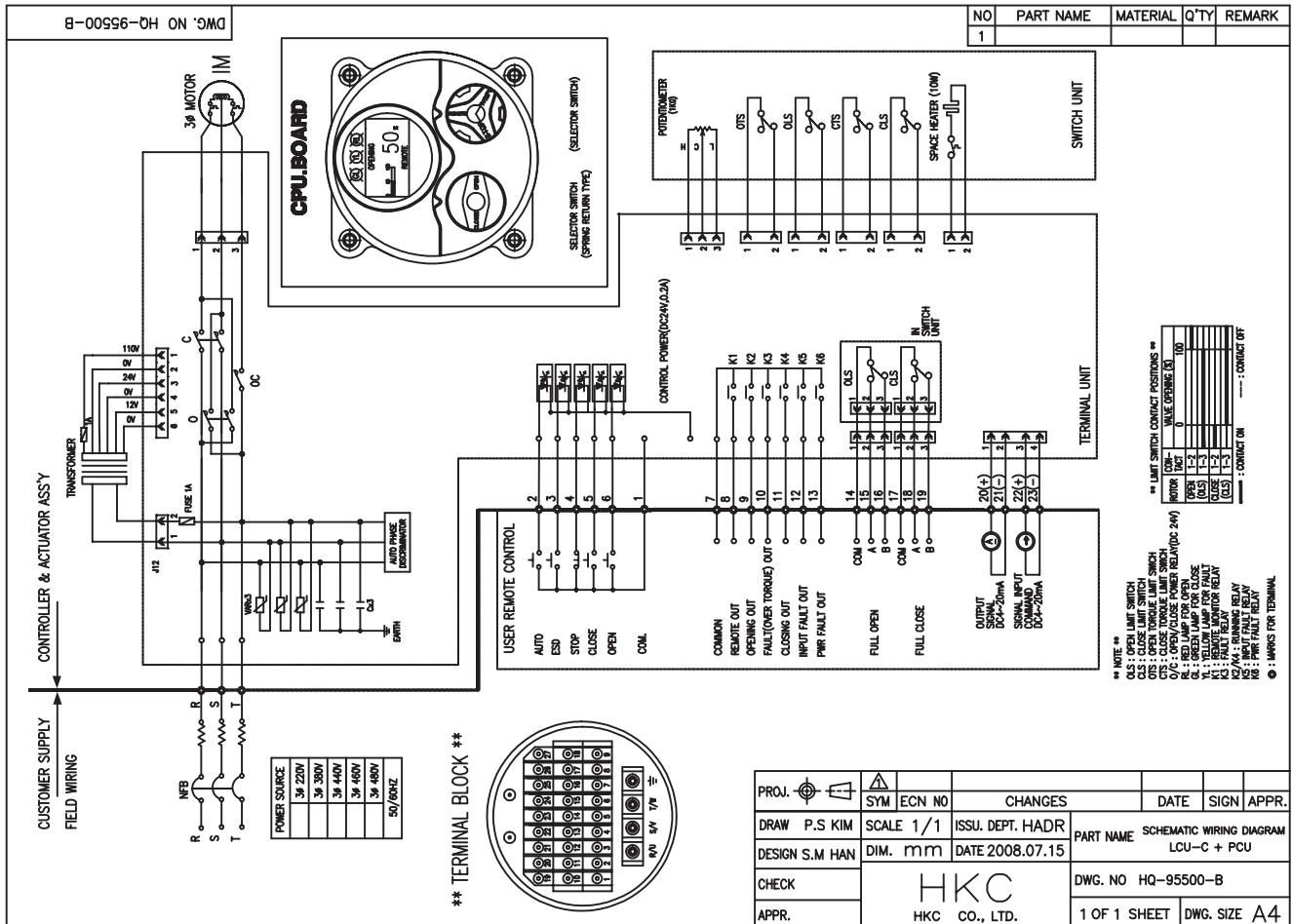

Electric Actuator Order Code

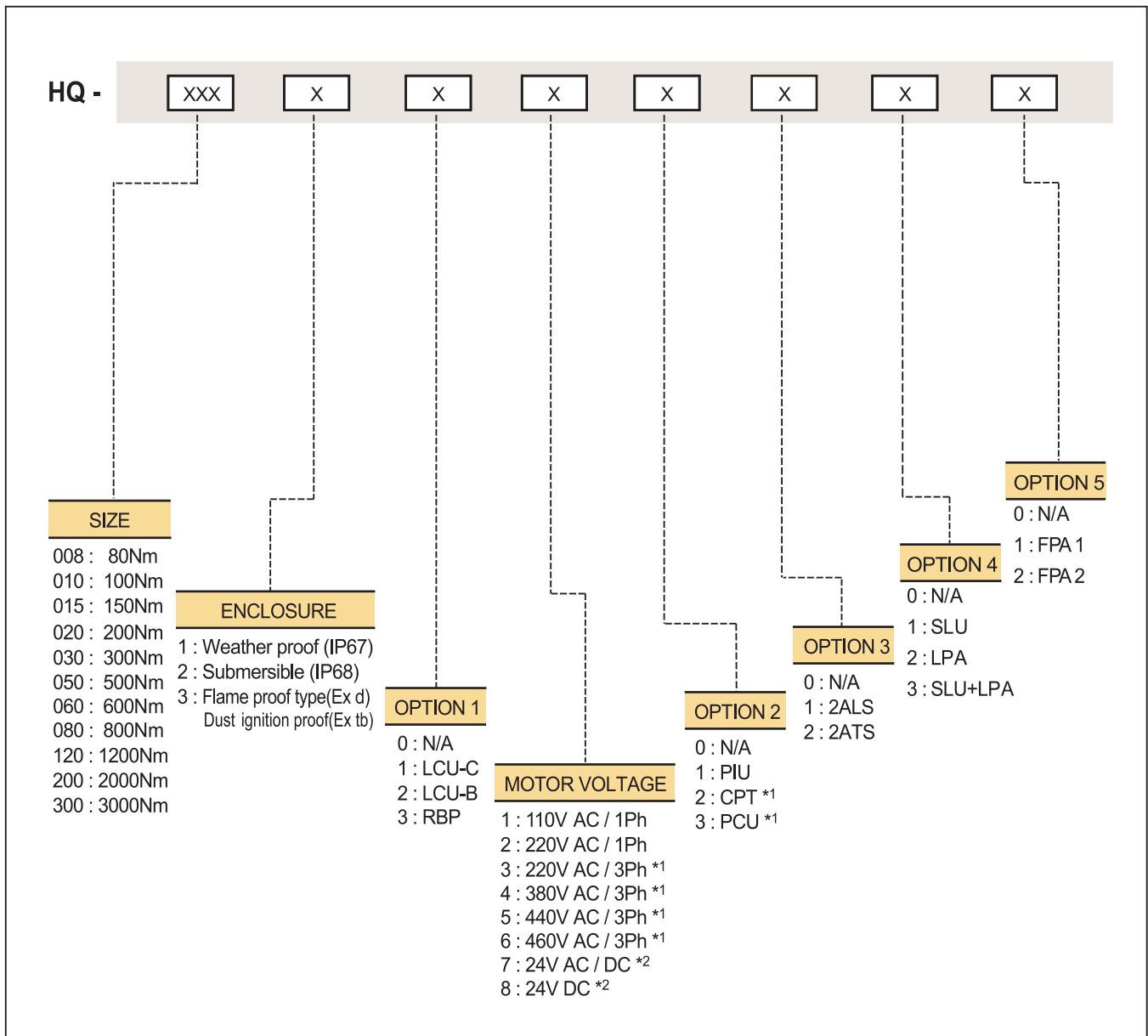

Remarks)

- Asterisk*1 : HQ-008 through 010 actuators shall not be applied to the above condition.
- Asterisk*2 : HQ-050 through 300 actuators shall not be applied to the above condition.
- 2ATS/2ALS shall not be available for HQ-008 and for HQ-015 through 020 actuators with PCU.
- When LCU-B option applied, HQ-015 through 300 actuators shall be available on the full condition of motor voltages except DC 24V.
- When LCU-C option applied, HQ-015 through 300 actuators shall be available on the condition of 220V through 460V 3 phase of voltages and shall not be available with PIU/CPT.
- Option RBP is available only for HQ-008, 010, 015, 020, 030.
- More details should be advised to the manufacturer.



Electric Actuator HQ-006 Series

HQ-006 Series

- HQ-006 Actuator is newly designed and developed for small size valve automation like ball, butterfly, plug and even dampers.
- Small, light and compact design, high torque and various control options will meet your specific requirements.
- HQ provides high technical service & quality products for your automation system.

Features

- Compact and light due to high grade aluminum alloy housing.
- High resistance from corrosion due to hard anodizing on inside & outside and polyester powder coating on external surface
- Output torque : 60Nm(6 kgf.m)
- The actuator motor is reversible, high torque and low current design.
- Solid with O-ring system giving weatherproof (IP67)

Standard Configuration

- Manual handwheel
- Wide, easy mounting base standard to ISO5211(F03/F05/F07)
- Standard 4 limit switches. 2 for operation, 2 for extra(dry contacts)
- Captive cover bolt.
- Space heater.
- Limit switches for easy and tight setting.
- Terminal block. (11P)
- Standard color : Red or Blue

Option Configuration

- Proportional Control Unit (PCU)

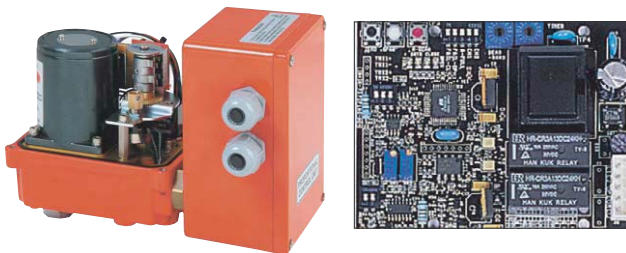

- HQ PCU is combined with an electronic positioner.
- Input signal range : 4~20mA, or 0~10VDC
- Output signal range : 4~20mA, or 0~10VDC
- Adjustable range : zero 8mA, open 16mA
- Position conversion accuracy : 0.5~1.5% (depends on installation)

- Position Indication Unit (Potentiometer kit, PIU)
High resolution potentiometer with precisely machined gearing directly engaged with driving shaft provides continuous monitoring of position of valve and actuator

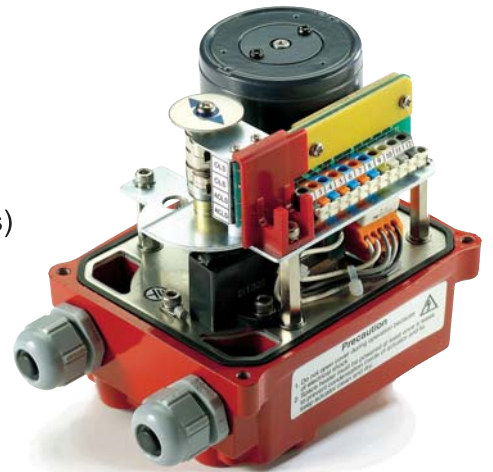

- AC-DC 24V Control Unit

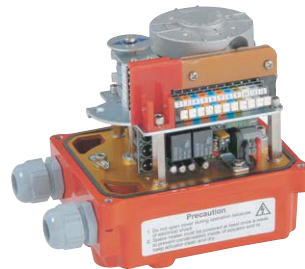

- AC or DC power input (2-wire) only by user
- Control function built inside



Performance

HQ (MODEL)	Maximum output torque		Operating time(sec.) 50/60Hz	Mounting		Rated current(A)			Duty cycle IEC 34-1	Number of handle turn	Weight
	Kgf.m	Nm		Drilling	Bore	DC	AC, 1 Phase(50/60Hz)				
			90°	ISO 5211	Ømm	24V	110V	220V	S4(%)	n	kg
HQ-006	6	60	14 / 12	F03 / F05 / F07	14	1.7	0.4/0.4	0.2/0.2	35	8	3

Standard Specification

Enclosure	Weatherproof enclosure IP67
Power supply	110/220V ac 1PH, 50/60Hz, ±10%
Duty cycle(on-off duty)	S4 35%
Motor	Reversible motor
Limit switches	Open/close, SPDT, 250V ac 10A rating
Additional limit switches	Open/ close, SPDT, 250V ac 10A rating
Space heater	2W (110/220V ac)Anti-condensation
Manual override	Handwheel (hexagon design)
Cable entries	Two PG 13.5 tap(Option : NPT1/2", PT1/2", PF 1/2")
Movement angle	320° ± 10° (0° ~330°)
Ambient temperature	-20°C ~+70°C (Ex d : -20~60°C)
External coating	Polyester powder coating

Option Specification

PIU	Potentiometer unit(0~1kΩ)
PCU	Proportional control unit (In/out:0~10V, 4~20mA DC)
CPT	Current position transmitter (Output 4~20mA DC)
ADCM	Multi(24VAC/DC)
DCM	DC motor (24VDC)
LCU	Local control unit -remote/local -open/stop/close

Dimension

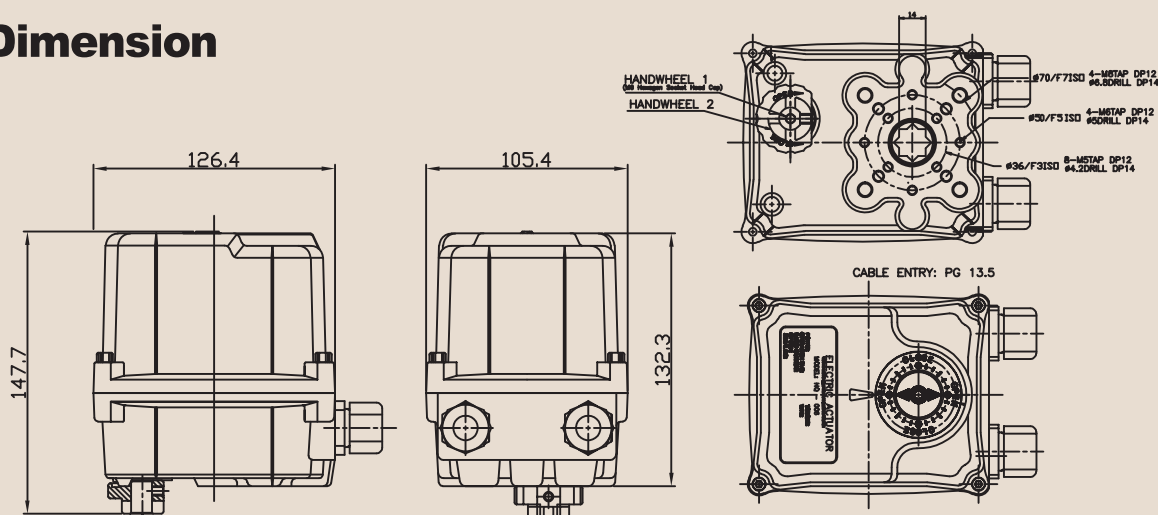

Application



with Butterfly Valves
Ball Valves
Plug Valves
Damper

Valve Automation (Rotary Motion Valves)

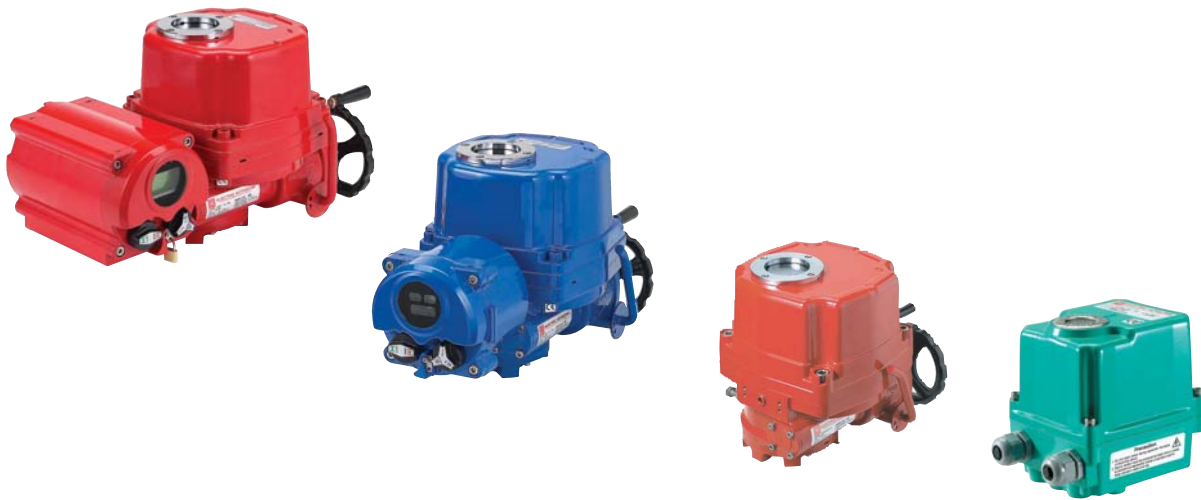

Distributed By:

RAM UNIVERSAL LTD.

Unit 20, Swannington Road
Broughton Astley
Leicestershire, LE9 6TU

T: 01455 285428 | ramuniversal.co.uk



세계일류상품



Hologram shall be put on all products manufactured in the factory.