

Title: **Installation, Operation & Maintenance Instructions -  
20 & 30 Double Acting & Spring Return Actuators**

SEAL REPLACEMENT INSTRUCTIONS FOR  
MODEL 20 & 30 ACTUATORS

**1. Dismantling Actuator**

Caution: Before dismantling, remove any burrs that there might be on square drive shafts to avoid damage to bearings and seals during dismantling/reassembly. In the case of spring return actuators, remove spring unit (refer to spring removal section) before dismantling actuators.

Note: Figure 2 shows a cross-section through a 20 actuator for reference.

- 1.1 Securely support the actuator by use of a bracket which is connected to the actuator mounting flange such that the actuator shaft axis is vertical.
- 1.2 Loosen case screws on upper half only but do not remove.
- 1.3 Separate this one case half by connecting an air line to inlet port and "blow" apart. Procedure is safe although produces a "bang". Re-tighten four screws at opposite corners of case.  
Caution: Do not hammer casings or shaft end as this may damage sealing surfaces.
- 1.4 Turn actuator over and repeat 1.2 and 1.3 for opposite case.
- 1.5 Remove top case screws completely and lift off top case.
- 1.6 Lift out uppermost vane with two people, one person gripping square on vane and the other lifting by the endstops on side plates.  
Caution: Ensure gloves and sleeved overalls are used, as the vane expander fingers are sharp and can easily cut hands and forearms.
- 1.7 Clean case halves and vane and remove silicone rubber sealant from joint faces using surgical spirit.
- 1.8 Attach lifting equipment to intermediate casing or a bar which can be bolted to flange for two people to lift casing. Lift casing clear of lower case. Ensure that splined coupling does not drop and damage cases as this is now unsupported.
- 1.9 Lift intermediate or lower vane from lower case as 1.6 except this time both lift points are on the side plates.
- 1.10 Clean intermediate casing, lower casing, lower vane and splined coupling using surgical spirit and remove silicone rubber from joint faces.
- 1.11 Replace and lubricate shaft seals.
- 1.12 Remove nuts from vane studs and remove sideplates, old expanders and seals. Clean vanes and remove surplus silicone rubber from around vane studs.
- 1.13 Check cases for any damage from vane and carefully remove any small end-loading damage using emery paper or a stone. If any of the damage is deep and likely to cause a high leakage, then fit a replacement case half.

**2. Re-Assemble Vanes**

- 2.1 Check studs are tight through vane and equal length each side. If not, apply Loctite 270 to thread and re-locate correctly in vane. Allow 1 hour minimum to cure.
- 2.2 Apply Silastic 732 RTV sealant around bottom of studs (to prevent air leakage through seal on vane stud holes).
- 2.3 Fit new vane seal over studs after checking profile matches vane profile and fit seal expanders.
- 2.4 Fit side plates over studs.
- 2.5 Fit new nylon inserted nuts to studs and tighten gradually in sequence as shown in figure 1 to 50 lb.in.
- 2.6 Later models of size 20/30 actuator vanes contain a nylon thrust pad which fits into the vane between the seals at the squared end of the vane. Ensure that this is located and does not fall out during assembly. The height of this pad is factory set and should not need adjustment.

Issue C	C.S. 25/04/12	<b>KINETROL</b> Trading Estate Farnham Surrey England	Doc.No. TD104 Page 1 of 6
------------	------------------	---	------------------------------

**FIGURE 1**

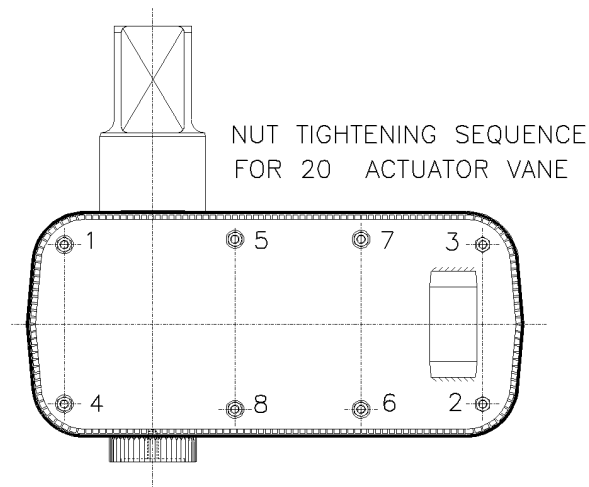

**3. Re-Assemble Actuator Case**

- 3.1 Coat bearing bushes and brush inside of cases with grease, keeping grease away from case joint faces.
- 3.2 Extrude a small bead of Silastic 732 RTV sealant onto lower case flange approximately 10mm from inside edge.
- 3.3 Insert lower vane into lower case, turning it as it is lowered to ease it through the shaft seal.
- 3.4 Mark position of vane on case outer surface so that upper vane can be placed in line at a future stage.
- 3.5 Coat splined coupling with molybdenum disulphide grease and fit onto vane.
- 3.6 Slowly lower intermediate case over vane spline coupling and locate on the two dowels.
- 3.7 Apply low strength thread adhesive to case screws and tighten screws to 1050 lb.ins. Wipe away any excess sealant that has extruded from case joint.
- 3.8 Lower upper (or intermediate for 30) vane into splined coupling ensuring that the vane lines up with the mark previously made on the lower vane.  
Caution: If the splines are not lined up correctly then full movement will not be obtained from the actuator. An alternative check on vane position can be made by checking the alignment of the squares.
- 3.9 Apply another bead of Silastic 732 RTV sealant to intermediate case flange (as in 3.2).
- 3.10 Lower upper (or intermediate for 30) actuator case over end of vane shaft again ensuring that shaft seal is not trapped and locate on dowels.
- 3.11 Fit bolts to case as in 3.7. For 30 models, repeat stages 3.2 to 3.11 for the upper vane & case.
- 3.12 Rotate vane to ensure one complete swipe of vane over joint face to spread excess Silastic on joint face as soon as possible after assembly. This can be achieved by applying just enough air to inlet port to make vane move.
- 3.13 Allow setting time for sealant before applying any more air.
- 3.14 Move vane to central position before refitting spring as described in spring fitting procedure, if necessary.

Title: **Installation, Operation & Maintenance Instructions -  
20 & 30 Double Acting & Spring Return Actuators**

**ADJUSTMENT OF END STOP SCREWS FOR  
(20 & 30 ACTUATORS)**

**Figure 2**

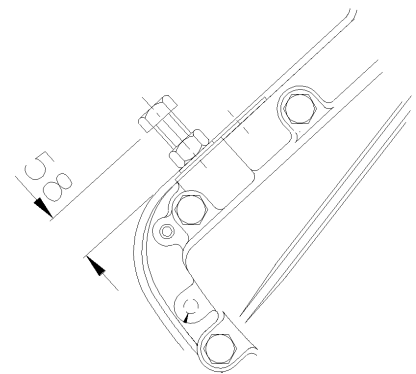
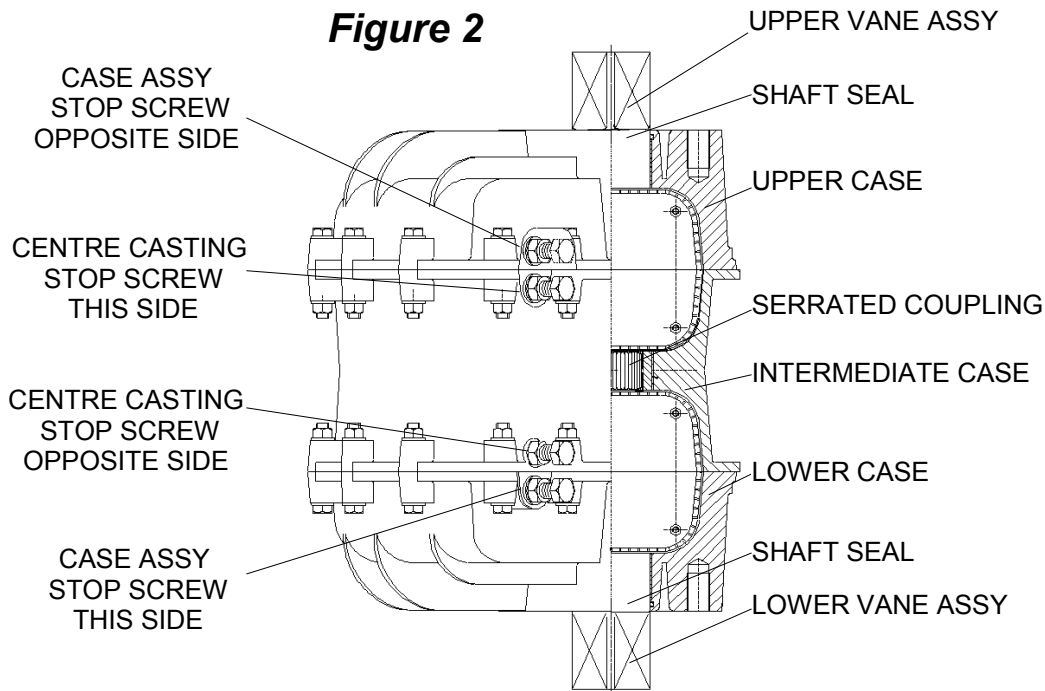

**Figure 3**

**4. Adjustment of End Stop Screws (20 & 30 actuators)**

20 actuators should be fitted with 2 travel stops on each side of actuator.

30 actuators should be fitted with 3 travel stops on each side of actuator.

It is desirable that the stop screws are adjusted such that the stopping load is shared equally.

To achieve this the following procedure should be followed:

4.1 To achieve a start position of 90 deg. travel, it is recommended that all of the travel stop screws are set as shown in figure 3. One screw on each side should be untouched, while the others are withdrawn by approximately 2 turns from this figure.

4.2 With the actuator fitted on the application (e.g. valve or damper) adjust the two / three working screws nearest the application to give the desired operating angle always ensuring that other screws protrude further from the side of the actuator case. Lock these two / three screws into position when the desired angle has been achieved using the lock nuts provided.

4.3 With air pressure applied to the actuator, screw in a non-working stop on the relevant side (the centre screw on 30 actuator) until it can be felt to contact the vane and screw in a further 1/2 turn (3 flats) for M20 stop screw or 1/3 turn (2 flats) for later actuators having M24 stop screws. Lock into position using the lock nut provided.

4.4 Turn the actuator to the other end of its stroke and repeat steps 4.2 & 4.3.

Issue C	C.S. 25/04/12	 Trading Estate Farnham Surrey England	Doc.No. TD104 Page 3 of 6
------------	------------------	---	------------------------------

**Title: Installation, Operation & Maintenance Instructions -  
20 & 30 Double Acting & Spring Return Actuators**

SPRING REMOVAL/REPLACEMENT INSTRUCTIONS  
FOR 20 & 30 SPRING RETURN ACTUATORS (EARLY INTEGRAL DESIGN)

**5. Removal of Spring Pack**

Warning: The wound-up springs store a large amount of energy which, if suddenly released, can be dangerous.

Note: Figure 4 shows main elements of spring pack.

- 5.1 Securely support actuator/spring unit in a vertical position by use of a bracket which is connected to the actuator mounting flange. This bracket will either need to be fixed to the floor or have a large stable base.
- 5.2 A keeper plate strong enough to take the full torque must be fitted in order to remove S/R pack without spring tension.
- 5.3 Connect airline via a pressure regulating valve to actuator air inlet.
- 5.4 Place the keeper plate over square shaft protruding from S/R pack.
- 5.5 Increase air pressure slowly until actuator vane turns to mid-travel position. Keeper plate holes will then line up with threaded holes in spring housing.
- 5.6 Insert four bolts through keeper plate holes and tighten to lock keeper plate in position and disconnect air supply.
- 5.7 Fit two lifting eyes to keeper plate and connect to suitable lifting equipment to later lift the spring pack from the actuator.
- 5.8 Remove four lower retaining nuts which retain the spring pack to the spring pack base. To remove the lower nuts may not be easy because the bolts may rotate. This can be overcome by either applying some actuator torque to hold the bolts or by sawing off the nuts. Once completed and the spring pack removed following the procedure below, then it is recommended that the pack be returned to Kinetrol Ltd. for updating. Remove air supply.
- 5.9 Slowly lift the spring pack vertically from the actuator ensuring that the actuator does not lift as well and that lower spring coupling moves with the spring pack.
- 5.10 Lower the spring pack on its side and fit a baseplate to the underside of the spring pack to protect the springs during storage/shipment.
- 5.11 Kinetrol recommend that this type of spring pack is returned to the factory for alteration to later design. For instructions for fitting later dismantlable design, refer to page 5.

Issue C	C.S. 25/04/12	<b>KINETROL</b> Trading Estate Farnham Surrey England	Doc.No. TD104 Page 4 of 6
------------	------------------	---	------------------------------

**Title: Installation, Operation & Maintenance Instructions -  
20 & 30 Double Acting & Spring Return Actuators**

**SPRING REMOVAL/REPLACEMENT INSTRUCTIONS  
FOR 20 & 30 SPRING RETURN ACTUATORS (LATER DISMOUNTABLE DESIGN)**

**6. Removal of Spring Pack**

Warning: The wound-up springs store a large amount of energy which, if suddenly released, can be dangerous.

- 6.1 Securely support actuator/spring unit in a vertical position by use of a bracket which is connected to the actuator mounting flange. This bracket will either need to be fixed to the floor or have a large stable base.
- 6.2 A keeper plate strong enough to take the full torque must be fitted in order to remove S/R pack without spring tension.
- 6.3 Connect airline via a pressure regulating valve to actuator air inlet
- 6.4 Place the keeper plate over square shaft protruding from S/R pack.
- 6.5 Increase air pressure slowly until actuator vane turns to mid-travel position. Keeper plate holes will then line up with threaded holes in spring housing.
- 6.6 Insert four bolts through keeper plate holes and tighten to lock keeper plate in position and disconnect air supply.
- 6.7 Fit two lifting eyes to keeper plate and connect to suitable lifting equipment to later lift the spring pack from the actuator.
- 6.8 Remove four lower retaining screws which retain the spring pack to the spring pack base.
- 6.9 Slowly lift the spring pack vertically from the actuator ensuring that the actuator does not lift as well and that lower spring coupling moves with the spring pack.
- 6.10 Lower the spring pack on its side and fit a baseplate to the underside of the spring pack to protect the springs during storage/shipment.
- 6.11 In the unlikely event that the spring pack is thought to be faulty, it is recommended that the pack is returned to Kinetrol for refurbishment.

**7. Re-Assembly of the Spring Return Pack**

- 7.1 Support the actuator as in 5.1.
- 7.2 If necessary replace spring base plate gasket.
- 7.3 Apply air pressure to actuator to move it to mid-travel position.
- 7.4 Fit new O ring seal onto baseplate register.
- 7.5 Lift spring pack using crane attached to lifting eyes in keeper plate.
- 7.6 Lower spring pack and locate on actuator square end and then onto baseplate register.
- 7.7 Rotate actuator vane by using air pressure to allow bolts to be fitted which retain the spring pack to base plate and tighten screws.
- 7.8 Adjust air pressure until the actuator balances the spring tension.
- 7.9 Loosen keeper plate screws. If the air pressure balances spring tension correctly the screws can be removed easily.
- 7.10 Remove keeper plate.
- 7.11 Disconnect air supply.

Issue C	C.S. 25/04/12	<b>KINETROL</b> Trading Estate Farnham Surrey England	Doc.No. TD104 Page 5 of 6
------------	------------------	---	------------------------------

Title: **Installation, Operation & Maintenance Instructions -  
20 & 30 Double Acting & Spring Return Actuators**

Figure 4

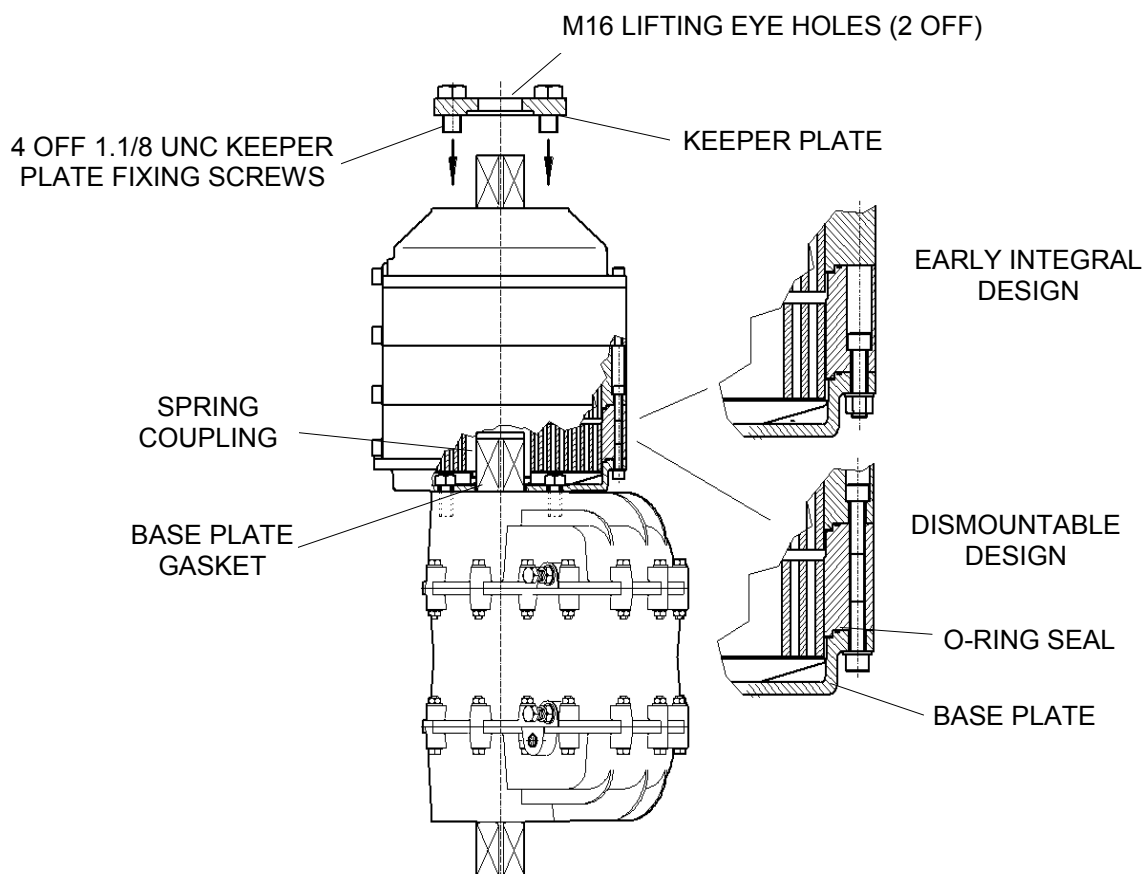

**8. Spring pack integrity check for 20 & 30 spring return actuators**

- 8.1 To check the integrity of a 20 or 30 spring return actuator, the actuator must first be removed from the valve so that all external loads are removed.
- 8.2 Connect an airline via a pressure regulating valve to the air inlet port (minimum of 3/8 air ports to be used).
- 8.3 Fit an indicator to the top of the spring pack shaft (e.g. a length of weld wire) so that small movements of shaft can be detected.
- 8.4 Increase the air pressure to the actuator gradually until the pointer can be seen to move and record the setting. Note: ensure that the leakage from the actuator is not excessive and the pressure change is very gradual otherwise a false reading may be obtained. The reading must always be taken as a rising signal.
- 8.5 The setting should be within the range below:

<u>Actuator Type</u>	<u>Min.rising pressure</u> <u>at start of</u>	<u>Actuator Type</u>	<u>Min.rising pressure</u> <u>at start of</u>
<u>20*-120-6500</u>	27 psi	<u>30*-120-7600</u>	17 psi
<u>20*-120-6600</u>	35 psi	<u>30*-120-7700</u>	22 psi
<u>20*-120-7200</u>	17 psi	<u>30*-120-7800</u>	29 psi
<u>20*-120-7300</u>	25 psi	<u>30*-120</u>	37 psi
<u>20*-120</u>	38 psi		

*\*Number can be 0,4,7 or 9; depends on order specification.*

- 8.6 It may be wise to check the pressure settings a few times to ensure a consistent reading is obtained.
- 8.7 Lower pressure and remove regulated inlet and pointer.