

Installation, Operation & Maintenance Instructions
ROTARY 1/4 TURN ACTUATOR / DOUBLE ACTING & SPRING RETURN MODELS
 Suitable for use in safe area and hazardous gas/dust atmospheres (ATEX)

GENERAL ACTUATORS & SPRING RETURNS

NOTE : ALL REFERENCES IN THIS DOCUMENT TO MODEL 08 ASSEMBLIES ARE SPECIFIC TO THE 2010 REDESIGN. FOR PRE 05/2010 08 MODELS CONTACT KINETROL.

1. INSTALLATION

Mounting hole sizes – Standard actuator

Model	Number of Holes	ISO Thread	Depth of Thread	ANSI Thread	Depth of Thread
01	4	M4 x 0.7	6mm	8-32 UNC	15/64"
02	4	M4 x 0.7	8mm	8-32 UNC	5/16"
03	4	M5 x 0.8	10mm	10-24 UNC	3/8"
05	6	M5 x 0.8	10mm	10-32 UNC	3/8"
07	4	M8 x 1.25	16mm	5/16-18 UNC	5/8"
08	4	M8 x 1.25	16mm	5/16-18 UNC	5/8"
09	4	M10 x 1.5	20mm	3/8-16 UNC	25/32"
12	4	M12 x 1.75	24mm	1/2-13 UNC	15/16"
14	4	M16 x 2	28mm	5/8-11 UNC	11/8"
15	4	M16 x 2	28mm	5/8-11 UNC	11/8"
16	4	M24 x 3	38mm	7/8-9 UNC	11/2"
18	4	M30 x 3.5	50mm	11/8-7 UNC	2"
20	8	M30 x 3.5	50mm	11/8-7 UNC	2"
30	8	M30 x 3.5	50mm	11/8-7 UNC	2"

Model 014P has 4 M4 (8-32 UNC) clearance holes.

Mounting hole sizes – DIN/ISO actuators

Model suffix 1 is without Namur.

Model suffix 2 is with Namur solenoid valve mounting.

Model suffix 3 is with ancillary mounting.

Model suffix A is with ancillary mounting and Namur solenoid valve mounting.

Model	Number of Holes	ISO Thread	Depth of Thread	PCD
031/3 & 032/A	4	M5 x 0.8	8mm	36mm
051/3 & 052/A	4	M5 x 0.8	8mm	42mm
071/3 & 072/A	4	M6 x 1	10mm	50mm
083 & 08A	4	M8 x 1.25	13mm	70mm
091/3 & 092/A	4	M8 x 1.25	13mm	70mm
101/3 & 102/A	4	M10 x 1.5	16mm	102mm
121/3 & 122/A	4	M10 x 1.5	16mm	102mm
141/3 & 142/A	4	M12 x 1.75	20mm	125mm
151/3 & 152/A	4	M16 x 2	28mm	140mm
161/3	4	M20 x 2.5	32mm	165mm

Mounting hole sizes for ISO adaptor models refer to Kinetrol technical data sheet TD124.

Mounting hole sizes for female spring return assemblies refer to Kinetrol technical data sheet TD121.

Note: It is essential that full number of bolts are used and all tightened evenly. Refer to TD 111.

CAUTION:

NEVER HAMMER OR USE OTHER UNDUE FORCE ON ACTUATOR DIECAST CASES. DAMAGE TO INTERNAL SEALING FACES WILL RESULT.

2. Mounting

2.1 Actuator and driven unit must be correctly aligned, i.e. actuator vane and driven unit must be able to move in same direction from end stop when coupled together.

Position of output square in mid-travel position.

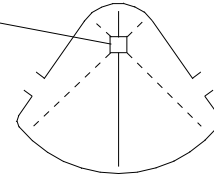

Note:

Position of output shaft when vane at mid-travel position.

- 2.2 Take particular care in aligning model 05. 6-hole mounting means 30° misalignment possible if flange has 60° error and coupling 90° error.
- 2.3 There must be no end load on actuator drive shaft. Check clearance between actuator and driven unit drive shaft, allowing for coupling to be used.
- 2.4 Care must be taken to ensure concentricity between actuator shaft and driven unit shaft.
- 2.5 Actuator can be mounted in any plane.
- 2.6 When side loading of actuator shaft is unavoidable, ensure load does not exceed guide lines given in Kinetrol Technical data sheet TD28.
- 2.7 Ensure the larger of the output square drives (if different) is used to drive the load.

3. Drive Coupling

3.1 Square hole standard drive coupling supplied in mild steel and may be welded or brazed to coupling part to suit drive on driven unit.

NOTE: This is not supplied with ISO/DIN, ISO adaptor or female spring drive models.

3.2 When the mounting is tightened down, check there is minimum 0.5mm (0.020") end play of coupling on actuator square drive shaft to avoid end load on actuator shaft.

4. Air/Gas Supply

- 4.1 Operating air pressure should not exceed 7 bar (100 psi).
- 4.2 Air/Gas supply must be reasonably clean and dry and to a quality class 4.5.5 (according to ISO standard 8573.1). This implies 25 micron maximum particle size, 7°C dew point maximum (or lower than ambient temperature below 7°C) and 25 mg/cubic metre maximum oil content.
- 4.3 Plastic or other non-conductive tubing is not recommended for use unless it is proven to comply with EN13463-1-2001 section 7.4.4. Size should be relative to supply/exhaust port size on actuator concerned. Undersize tubing or fittings will restrict actuator performance.
- 4.4 The actuator can be driven by a hazardous gas as long as:
 - 4.4.1 The gas is not corrosive (e.g. natural gas "sweet" and not "sour" gas is used).
 - 4.4.2 The gases must not be used within their flammable range.
- 4.5 Air can be passed to the actuator from three different sets of air port. One is through the side holes for fast response. Two holes at the rear of the actuator can be unplugged or a Namur adaptor fitted for using a Namur standard valve or two air holes in the top flange of the actuator by unplugging holes and fitting a Kinetrol positioning product (Models 05-15).

Installation, Operation & Maintenance Instructions

ROTARY 1/4 TURN ACTUATOR / DOUBLE ACTING & SPRING RETURN MODELS

Suitable for use in safe area and hazardous gas/dust atmospheres (ATEX)

5. Operation

- 5.1 External stops are strongly recommended when actuator is operating a mechanism with cantilevered load. However, Kinetrol technical data sheet, TD37, can be used to ensure load inertia and travel speed remain within allowable limits.
- 5.2 Second square end of drive shaft may be used for visual position indication, emergency manual operation or driving of add-on units (positioner, limit switch unit, etc.).
- 5.3 If the square sizes are the same both ends spring units can be fitted either end. However, if they are different, always fit the spring to the larger square end and drive through this end only.
- 5.4 Ambient operating temperature range of actuator is -20°C to 80°C. This range may be extended to +100°C with Viton seals. Special care should be taken to ensure that heat conducted from, for example, a hot valve, does not increase the actuator temperature above these limits. Refer to Kinetrol technical data sheet TD69 for guidance. A low temperature version of the actuator, having an 'L' at the end of the type code allows the unit to be used at an ambient temperature range of -40°C to 70°C, such actuators may be labelled with a special ATEX label (see section 8).
- 5.5 Visual position indicators are available. Coloured red, made from Nylon 6, they can be fitted over square shaft at top of actuator or top of add-on unit.
- 5.6 Ensure environmental conditions, such as corrosive environments, are compatible with the materials of construction and protective finishes (Kinetrol technical data sheet TD14 refers). If unsure contact Kinetrol. Excessive corrosion of the actuator may cause it to fail in service.
- 5.7 Ensure operating speeds are less than 1 m/s for Cat 1 atmospheres and 4m/s for cat 2 atmospheres, see table below for maximum operating travel times:
- 5.8 Ensure any build up of dust is removed and regular checks are made.

Model	Category 1 operating time for 90° travel (sec)	Category 2 operating time for 90° travel (sec)
01	0.056	0.014
02	0.067	0.017
03	0.085	0.021
05	0.107	0.027
07	0.143	0.036
08	N/A	0.042
09	N/A	0.046
10	N/A	0.047
12	N/A	0.060
14	N/A	0.081
15	N/A	0.091
16	N/A	0.415
18	N/A	0.545
20/30	N/A	0.540

6. Maintenance

Maintenance is limited to replacement of seals when wear affects actuator performance. Seal life will vary according to application, conditions of cycle frequency, temperature, condition of air supply, etc. Detailed seal replacement instructions in next section.

7. Recommended Spare Parts (Refer to pages 5 - 8)

Standard seal kits, available for each actuator model, consist of the following:

- 2 off vane seal - 2 off expander - 2 off shaft seal
- Plus all necessary O-rings, screws, nuts and grease for all sizes up to model 15.

In addition, a tube of sealant will be required to seal case halves. Spring return units are not user servicable and therefore no spare parts are available other than complete units and keeper plates for safe spring removal.

8. Labelling (ATEX)

All Kinetrol actuators that are approved for use in areas where explosives, dust & gases are present, are marked with one of the following labels:

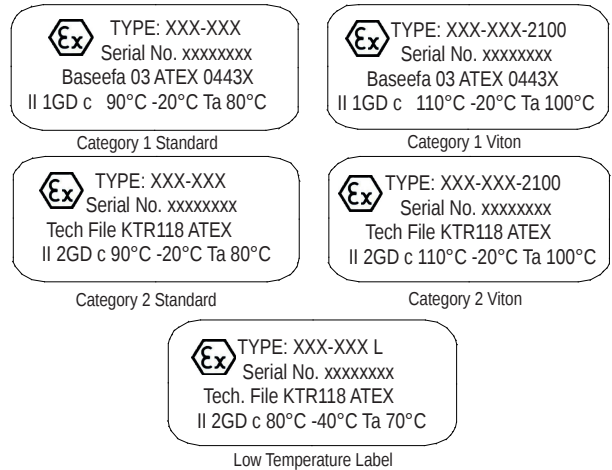

Ensure that the details on the label such as the ambient temperature range is suitable for the application. Also ensure that any other equipment fitted to the actuator (e.g. limit switch box or positioner) does not restrict the use within the parameters shown on the above labels. Certificate of Conformance, TD125, shows the category of approval for different sizes of actuator and spring unit.

9. Adjustment

- 9.1 Stroke Adjustment – only applies to models with adjustable stops.

Table of standard stroke adjustments available
Adjustment range available

Models	Each stop
03/07/08/09/15/16/18/20/30	10°
02/05/14	8°
01A/10/12	11°

Greater adjustment range possible with non-standard stop screws. Contact KINETROL for details.

- 9.2 Speed Adjustment

Slower operation of actuator is possible, without significant torque output reduction, by external fitment of flow regulator valves.

Faster operation can be achieved under certain conditions by fitting quick exhaust valves. For full details contact Kinetrol.

Installation, Operation & Maintenance Instructions
ROTARY 1/4 TURN ACTUATOR / DOUBLE ACTING & SPRING RETURN MODELS
 Suitable for use in safe area and hazardous gas/dust atmospheres (ATEX)

ACTUATOR SEAL REPLACEMENT INSTRUCTIONS

1. DISMANTLING ACTUATOR (see exploded drawing/parts list) CAUTION: Before dismantling, check there are no burrs on square drive shafts. If there are, remove to avoid damage to bearings and shaft seals during removal of case halves. In the case of spring return actuators, remove spring unit (according to following section) before opening actuator case.
 FOR DISMANTLING/RE-ASSEMBLY INSTRUCTIONS FOR 20/30 SIZE ACTUATOR REFER TO KINETROL TECHNICAL DATA SHEET TD104.

- 1.1 All models: loosen, but do not remove, all case screws.
- 1.2 Separate case halves by connecting air line to inlet port and blowing them apart. Procedure is safe although producing a "bang". Pull off one case half.
 CAUTION: Do NOT hammer diecast castings or shaft end. It will damage internal sealing surfaces.
- 1.3 Clean both case halves removing silicone rubber sealant. Clean joint surfaces of case flange with surgical spirit.
- 1.4 Replace and lubricate shaft seals.
- 1.5 Undo vane nuts and bolts (if fitted) and remove old expanders and seals from vane. Take care not to damage side plates. Clean vane. Some later models use nuts on one side of vane with bolts on other side.

2. REASSEMBLY VANE
Vane sub assembly with studs

- 2.1 Check studs are tight through vane and equal length each side (if studs are fitted). If not, apply Loctite to thread and relocate correctly in vane.
- 2.2 Model 18: Apply SILASTIC 732 RTV sealant around bottom of studs (to prevent air leakage through seal on vane stud holes).
- 2.3 Fit new seal over studs after checking profile matches vane profile.
- 2.4 Fit seal expander – the hole in it shaped like vane outline shows correct way round – teeth pointing away from vane.
- 2.5 Fit side plate over studs.
- 2.6 Fit new nuts to studs after applying Loctite medium strength sealant to threads.
- 2.7 Tighten nuts to following torques:

01	6 lbf.ins	0.07	m kg
02	6 lbf.ins	0.07	m kg
03	6 lbf.ins	0.07	m kg
05	8 lbf.ins	0.09	m kg
07	8 lbf.ins	0.09	m kg
08	20 lbf.ins	0.23	m kg
09	20 lbf.ins	0.23	m kg
10	20 lbf.ins	0.23	m kg
12	30 lbf.ins	0.35	m kg
14	30 lbf.ins	0.35	m kg
15	30 lbf.ins	0.35	m kg
16	60 lbf.ins	0.69	m kg
18	60 lbf.ins	0.69	m kg

Vane sub assembly with hex head bolts

- 2.8 Check vane for any obvious defects and make sure it is free of burrs, then place vane in cradle and place face down on a bench or hold in a vice.
- 2.9 Push hex headed bolts with plain washer through side plate, expander (teeth facing towards head of bolt) and seal (base of seal away from bolt head).

- 2.10 After checking that expander and seal are right way round - expander has vane shaped hole, seal has shaft centre line marked - thread first few threads of each bolt into vane.
- 2.11 While holding up side plate, expander and seal, apply a low strength anaerobic adhesive to bolt thread.
- 2.12 Screw bolts down and tighten to torques given below.
- 2.13 Turn vane over then fit seal, expander and side plate over end of bolts. Check orientation as before.
- 2.14 Screw nuts down thread.
- 2.15 Position vane assembly in coupling on bench, hold head of bolt with a spanner, torque up nut to torque specified in section 2.7.

Hex Head Bolts

01	6lbf./ins	0.07 m kg
07	8lbf./ins	0.09 m kg
08	10lbf./ins	0.12 m kg
09	10lbf./ins	0.12 m kg
10	15lbf./ins	0.17 m kg
12	30lbf./ins	0.35 m kg

3. RE-ASSEMBLING ACTUATOR

- 3.1 Coat bearing bushes and inside both case halves with molybdenum disulphide grease or grease supplied by KINETROL.
- 3.2 Lightly and evenly coat joint face on each case half with INSTANT GASKET sealant (up to Model 14) available from Kinetrol (SP057) or Loctite, or SILASTIC 732 RTV sealant (Model 16 up) obtainable from ironmongers, etc. may be used as a substitute. CAUTION: EXCESS SEALANT, if extruded inside case, WILL IMPAIR OPERATION OF SEALS. Remove all excess sealant especially from inside edge.
- 3.3 Insert vane into one case half, turning it to ease square on drive shaft through shaft seal. Watch that lip seals at ends of vane easily work down into case without damage.
- 3.4 Fit remaining case half on top of the other, turning it to ease square through shaft seal.
- 3.5 CAUTION: Check that lip seals are not trapped at case joint face when Viton seals are fitted. Ensure minimal time delay to closing of case once sealant has been applied

3.6 Tighten case screws to the following torques:

01	10 lbf.ins.	0.12 m kg
02	10 lbf.ins.	0.12 m kg
03	10 lbf.ins.	0.12 m kg
05	20 lbf.ins.	0.23 m kg
07	24 lbf.ins.	0.27 m kg
08	60 lbf.ins.	0.7 m kg
09	60 lbf.ins.	0.7 m kg
10	80 lbf.ins.	0.9 m kg
12	100 lbf.ins.	1.2 m kg
14	120 lbf.ins.	1.4 m kg
15	225 lbf.ins.	2.6 m kg
16	860 lbf.ins.	10 m kg
18	1140 lbf.ins.	13 m kg

- 3.7 Rotate vane manually to check movement and wipe away sealant extruded internally.
- 3.8 Allow setting time for sealant before applying test air pressure.

Installation, Operation & Maintenance Instructions
ROTARY 1/4 TURN ACTUATOR / DOUBLE ACTING & SPRING RETURN MODELS
 Suitable for use in safe area and hazardous gas/dust atmospheres (ATEX)

SPRING RETURN UNITS

NOTE : ALL REFERENCES IN THIS DOCUMENT TO MODEL 08 ASSEMBLIES ARE SPECIFIC TO THE 2010 REDESIGN, AND REFERENCES TO MODEL 05 ASSEMBLIES ARE SPECIFIC TO THE 2014 REDESIGN. FOR PRE 05/2010 08 MODELS AND PRE 02/2014 05 MODELS CONTACT KINETROL.

1. REMOVAL OF SPRING RETURN UNIT

WARNING – the wound-up steel springs are storing a large amount of energy which, if suddenly released, can be dangerous.

- 2.7 Remove keeper plate completely.
- 2.8 Disconnect air supply.

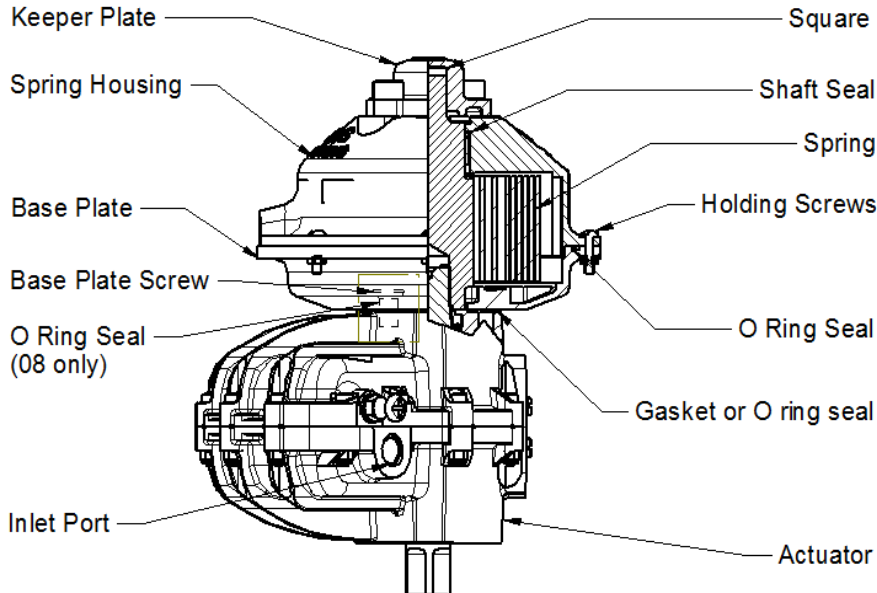

- 1.1 A keeper plate strong enough to take full spring torque must be fitted in order to remove S/R unit without releasing spring tension.

Note: Keeper plates and screws available from KINETROL. Refer to table on page 5 for spare part order Numbers.

- 1.2 Connect air line via pressure regulating valve to actuator air inlet.
- 1.3 Place keeper plate over square shaft protruding from S/R unit. Keeper plates with male squares can be provided for female drive spring packs.
- 1.4 Increase air pressure slowly until actuator vane turns to mid-travel position. (See sketch at 2 of ACTUATOR section.) Keeper plate holes will then line up with threaded holes in spring housing.
- 1.5 Insert all screws through keeper plate holes and tighten to lock keeper plate in position. Disconnect air supply.
- 1.6 Separate spring housing from base plate by removing holding screws. Then remove spring housing.
- 1.7 If necessary to gain access to actuator screws also remove base plate by removing screws. Take care with gasket/o ring between base plate and actuator. (Service actuator as required per Seal Replacement Instructions).

2. REASSEMBLY OF SPRING RETURN UNIT

- 2.1 If necessary replace base plate after replacing gasket or O-ring as appropriate. Ensure the 4 countersunk base plate fixing screws are all fitted with O-rings (08 models only).
- 2.2 Ensure actuator vane is in mid-travel position.
- 2.3 Locate spring housing on shaft, (if the actuator square size is different on one end ensure spring is fitted to correct drive end) rotate it to line up holding screw holes with base plate and replace holding screws.
- 2.4 Connect air supply (as in 1.2) to actuator inlet port.
- 2.5 Adjust air pressure until it balances the spring tension.
- 2.6 Loosen keeper plate screws. If air pressure correctly balancing spring tension will not bind. If binding, adjust air pressure until balanced.

3. ADJUSTMENT SPRING TENSION

WARNING: The wound-up steel springs are storing a large amount of energy which, if suddenly released, can be dangerous.

3.1 Tension Setting Definitions

- 3.1.1 Optimum setting is when S/R unit is able to provide as much output torque on the spring return stroke as that produced by the corresponding air stroke at a particular air supply pressure.
- 3.1.2 Differential setting is when S/R unit produces more or less output torque on spring return stroke as that produced by the corresponding air stroke at a particular air supply pressure.
- 3.1.3 Operating air pressure in these instructions means the actual air supply pressure at which the actuator will be operated.

3.2 Optimum Spring Setting Test

- 3.2.1 Detach actuator/spring return from valve or mechanism operated by them.
- 3.2.2 Attach air supply to actuator through pressure regulating valve and gauge with supply shut off at regulator.
- 3.2.3 Gradually open regulator to increase air supply to actuator until actuator output shaft just begins to move.
- 3.2.4 Note actual pressure at which actuator output shaft moved.
- 3.2.5 If actual pressure noted at 3.2.4 is about half the operating air pressure then spring tension is at optimum. If actual pressure noted at 3.2.4 is significantly less than half operating air pressure then spring tension is below optimum, i.e. output torque on S/R stroke will be less than that produced on corresponding air stroke at operating air pressure.

Installation, Operation & Maintenance Instructions
ROTARY 1/4 TURN ACTUATOR / DOUBLE ACTING & SPRING RETURN MODELS
 Suitable for use in safe area and hazardous gas/dust atmospheres (ATEX)

Conversely if actual pressure at 3.2.4 is significantly greater than half operating pressure then spring tension is above the optimum, i.e. S/R torque will be greater than air stroke torque.

WARNING: Spring tension must not be further increased if air pressure noted at 4.2.4 is 40 p.s.i. or more for standard S/R units or 30 p.s.i. for special low air supply types.

3.3 Tension Adjustment Method (Standard S/R units without worm drive)

3.3.1 Equipment/facilities required:

Air supply with pressure regulator valve and gauge in line.
 Keeper plate with bolts and spacers (KINETROL supply).
 Spanner/tools to suit.

Means of securely fixing assembly to a suitable work bench.

3.3.2 Detach actuator/spring return from valve/mechanism.

3.3.3 Connect air supply to actuator with regulator shut off.

3.3.4 Carry out optimum spring setting test as at 2.2 above to determine whether spring tension needs to be increased or decreased.

3.3.5 Gradually open air supply regulator until actuator vane is at centre of travel (45°) position (see sketch at page 1).

3.3.6 Place keeper plate over S/R square shaft at top of S/R unit.

CAUTION: If keeper plate of flat type, spacer washers at least 3mm (1/8") thick must be used under keeper plate. KINETROL die cast keeper plates do not need spacer washers.

3.3.7 If bolt holes of keeper plate do not line up with corresponding tapped holes in S/R unit, carefully open or close air supply regulator until S/R square shaft turns so that holes do line up.

3.3.8 Insert and tighten keeper plate bolts.

3.3.9 Shut off air supply to actuator.

3.3.10 Undo and remove all spring housing flange bolts.

Leave spring housing resting on base plate.

3.3.11 Turn spring housing in required direction according to:

- a) S/R operating direction, i.e. clockwise or anticlockwise operation of spring force, and
- b) Tension required to be increased or decreased.

NOTE: Larger sizes of actuator/spring return will require spanner and possibly extension bar to turn spring housing through square shaft on S/R unit.

3.3.12 Housings can be adjusted in steps of either 10°, 15°, 30° or 45° depending on the number of bolt holes around the flanges of the housing and base plate which varies with model and age of S/R unit concerned. (Except 014 = 90° steps only). **IMPORTANT** see paragraph 3.3.20.

3.3.13 As a rough guide 30° adjustment of spring housing relative to base plate will give 8% change of spring torque output providing spring is already tensioned within its operating air pressure range, i.e. standard S/R units between 50 and 80 p.s.i. Low air supply S/R units between 25 and 50 p.s.i. See catalogue for full details.

3.3.14 Maximum adjustment in one step will be 45° controlled by available vane movement in actuator.

3.3.15 After turning spring housing by amount required (or possible) line up bolt holes in spring housing and base plate flanges. Insert flange bolts and tighten nuts.

3.3.16 Carefully open air supply to actuator until side load on keeper plate bolts is relieved.

3.3.17 Remove keeper plate.

3.3.18 Repeat optimum spring setting test as at 4.2 above.

3.3.19 If necessary, repeat operations 4.3.5 to 4.3.17 to further increase or decrease spring tension.

3.3.20 Note: If alignment of mounting holes to square is important, then the spring tension should only be set in 90° increments. This is especially important when the spring unit is fitted between the actuator and the valve, as the mounting angle to the valve will determine correct opening/closing of the valve.

4. LABELLING (ATEX)

All spring units that are suitable for use in explosive areas are labelled with one of the labels as shown in 8 in actuator section above.

Ensure that the details on the label such as the ambient temperature range is suitable for the application.

Also ensure that any other equipment fitted to the spring return (e.g. limit switch box or positioner) does not restrict the use within the parameters shown on the above labels. Certificate of Conformance, TD125, shows the category of spring return approval for different sizes of spring units.

5. SPARE PART ORDER CODES – KEEPER PLATES:

SPRING SIZE	MALE DRIVE	FEMALE ISO DRIVE	FEMALE SERRATED DRIVE
01	SP 350	N/A	N/A
02	SP 351	N/A	N/A
03	SP 352	SP 1360/1	N/A
05	SP 353	SP 1362/3	SP 1480
07	SP 354	SP 1364	SP 1481
08	SP 904	SP 1378	SP 1483
09	SP 356	SP 1365	SP 1482
10	SP 359	SP 1366	SP 1482
12	SP 357	SP 1368	SP 1370
14	SP 358	SP 1371	N/A
15	SP 919	SP 1379	N/A
16	SP 360	SP 1372	N/A
18	SP 361	SP 1373	N/A
20	SP 362	SP 1374	N/A
30	SP 362	N/A	N/A

For non-standard spring codes please contact Kinetrol.

Installation, Operation & Maintenance Instructions
ROTARY 1/4 TURN ACTUATOR / DOUBLE ACTING & SPRING RETURN MODELS
 Suitable for use in safe area and hazardous gas/dust atmospheres (ATEX)

EXPLODED VIEW OF A TYPICAL STANDARD ACTUATOR

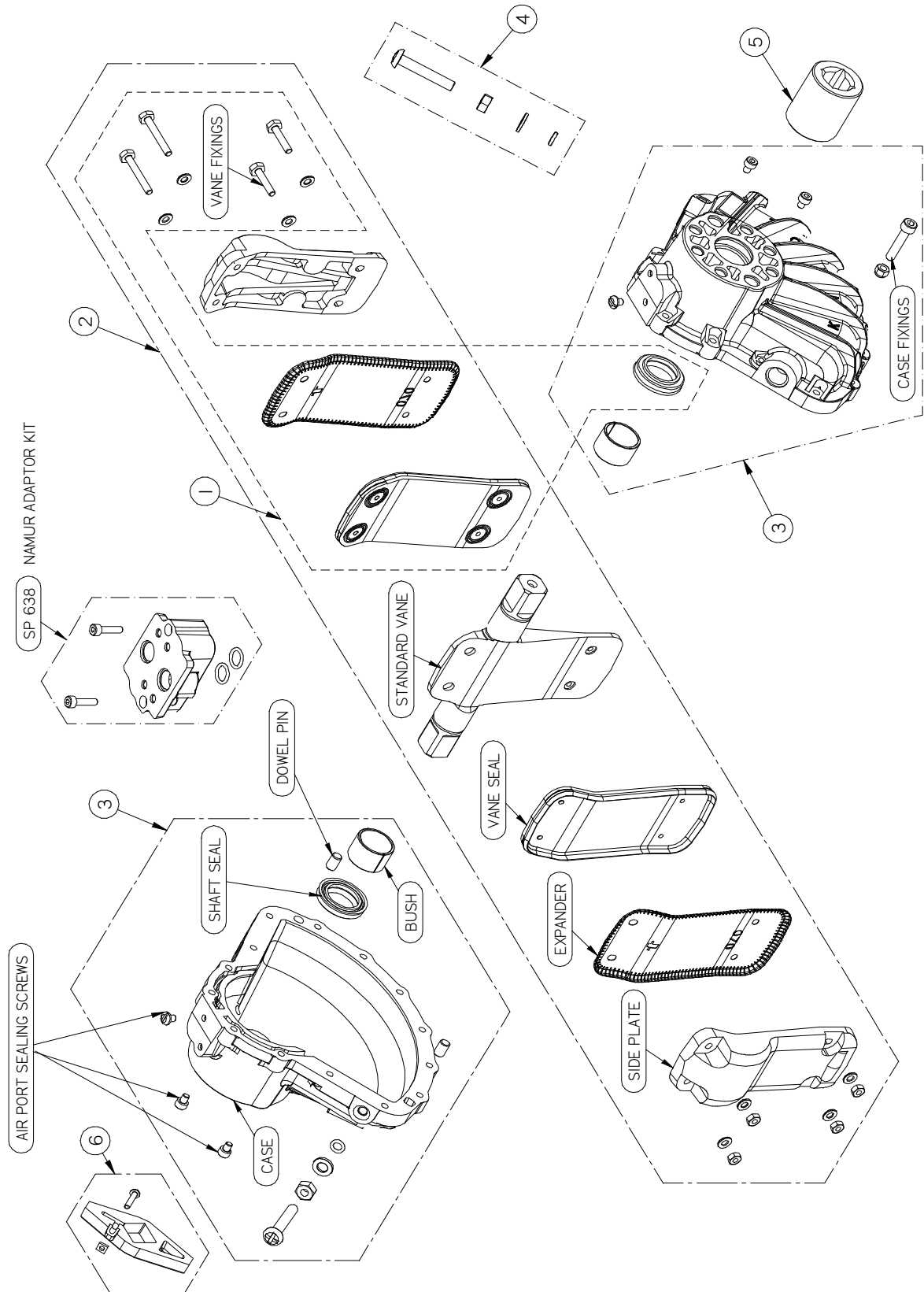

Installation, Operation & Maintenance Instructions
ROTARY 1/4 TURN ACTUATOR / DOUBLE ACTING & SPRING RETURN MODELS
 Suitable for use in safe area and hazardous gas/dust atmospheres (ATEX)

EXPLODED VIEW OF A TYPICAL ISO/DIN ACTUATOR

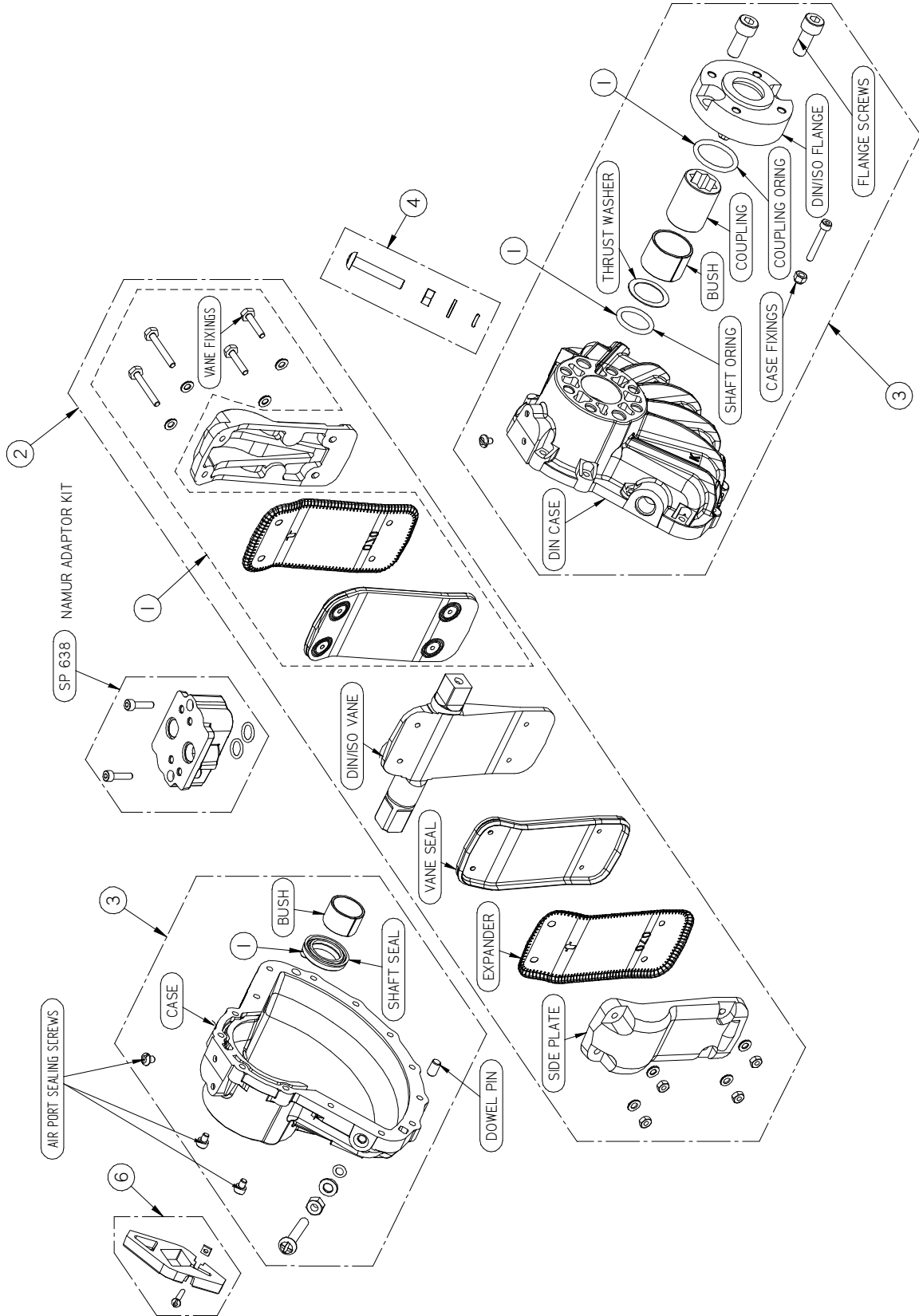

Installation, Operation & Maintenance Instructions
ROTARY 1/4 TURN ACTUATOR / DOUBLE ACTING & SPRING RETURN MODELS
 Suitable for use in safe area and hazardous gas/dust atmospheres (ATEX)

SPARE PART ORDERING CODES

NOTE : ALL REFERENCES IN THIS DOCUMENT TO MODEL 08 ASSEMBLIES ARE SPECIFIC TO THE 2010 REDESIGN. FOR PRE 05/2010 08 MODELS CONTACT KINETROL.

SPARE PART ORDERING CODES FOR STANDARD ACTUATOR

ITEM NO.	DESCRIPTION	QTY	SPARE NO'S FOR ACTUATORS														
			0M0	014	024	034/B	054/B	074/B	084/B	094/B	124/B	144/B	154/B	164	184	204	304
1	Seal Kit	1	SP055	SP871	SP041	SP054	SP042	SP043	SP900	SP045	SP046	SP047	SP917	SP053	SP048	SP051	SP052
2	Vane assembly	1	SP081	SP872	SP091	SP471	SP121	SP151	SP901	SP212	SP262	SP278	SP915	SP371	SP311	SP400	-
3	Case assembly	Matched Pair	SP083	SP873	SP099	SP479	SP129	SP159	SP902	SP221	SP253	SP283	SP916	SP379	SP319	SP399	-
4	Stop assembly	2	-	SP874	SP104	SP485	SP138	SP165	SP905	SP227	SP260	SP292	SP920	SP384	SP324	SP396	SP396
5	Coupling	1	-	SP074	SP106	SP487	SP140	SP167	SP903	SP229	SP264	SP298	SP918	SP386	SP326	SP406	SP406
6	Indicator assembly	1	-	-	SP108	SP489	SP146	SP171	SP171	SP171	SP171	SP171	-	-	-	-	-
	Namur adaptor	1	-	-	-	SP638							-	-	-	-	

VARIATIONS FOR OLD STYLE ACTUATOR PARTS

ITEM NO.	DESCRIPTION	QTY.	SPARE NO'S FOR ACTUATORS														
			0M0	010	010A	020	030	050	070	080	090	120	140	160	180	200	300
2	Standard Vane assembly	1	SP081	SP061	SP331	SP091	SP471	SP121	SP151	*	SP211	SP241	SP271	SP371	SP311	SP400	-
3	Standard Case assembly	Matched Pair	SP083	SP069	SP338	SP099	SP479	SP129	SP159	*	SP221	SP253	SP283	SP379	SP319	SP399	-
6	Indicator assembly	1	-	-	-	SP108	SP489	SP146	SP171	-	SP231	SP267	SP301	-	-	-	-

* CONTACT KINETROL

For actuators built to 'ANSI' standard (e.g. 057-100) change spare part number prefix
 from 'SP' to 'ASP' (e.g. for actuator 057-100 item 2 becomes ASP142
 or for 059-100 item 2 becomes ASP121).

SPARE PART ORDERING CODES FOR ISO/DIN ACTUATOR

ITEM NO.	DESCRIPTION	QTY.	SPARE NO'S FOR ACTUATORS										
			023/A	033/A	053/A	073/A	083/A	093/A	103/A #	123/A	143/A	153/A	163/A
1	Seal Kit	1	SP041	SP054	DSP042	DSP043	DSP900	DSP045	SP056	SP046	SP047	SP917	SP053
2	Vane assembly	1	SP091	DSP472	DSP142	DSP169	DSP901	DSP212	DSP801	DSP262	DSP283	DSP915	DSP371
3	Case assembly	Matched Pair	SP099	DSP480	DSP130	DSP160	DSP902	DSP222	DSP811	DSP263	DSP294	DSP916	DSP379
4	Stop assembly	2	SP104	SP485	SP138	SP165	SP905	SP227	SP817	SP260	SP292	SP920	SP384
6	Indicator assembly	1	SP108	SP489	SP146	SP171	SP171	SP171	SP171	SP171	SP171	SP171	-
	Namur adaptor		-	SP638									-

VARIATIONS FOR OLD STYLE ISO/DIN ACTUATOR PARTS

ITEM NO.	DESCRIPTION	QTY.	SPARE NO'S FOR ACTUATORS								
			021	031	051	071	091	101	121	141	161
2	Vane assembly	1	SP041	DSP471	DSP121	DSP151	DSP211	DSP800	DSP241	DSP271	DSP371
3	Case assembly	Matched Pair	SP099	DSP479	DSP129	DSP159	DSP221	DSP811	DSP253	DSP283	DSP379
6	Indicator assembly	1	SP108	SP489	SP146	SP171	SP231	DSP820	SP267	SP301	-

NOTE SIZE 10 CASE /VANE CONSTRUCTION IS SIMILAR TO STANDARD ACTUATOR